

knitking

ROYAL LOOM

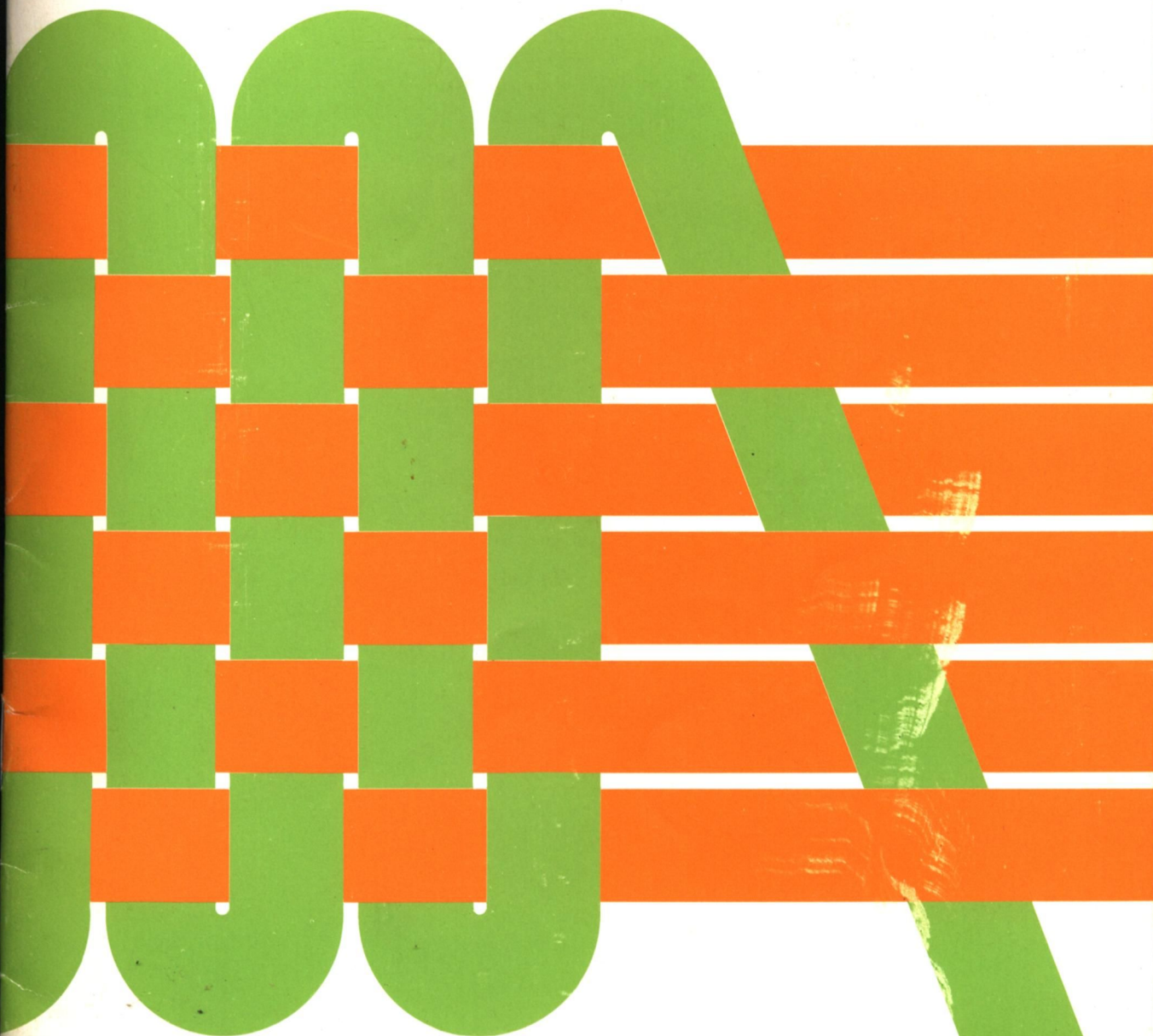

Instruction manual

This Manual has been designed so that you can easily understand the operation of your NEW ROYAL LOOM on a step-by-step basis.

After completing the basic instructions, you will have a thorough understanding of the Loom and be ready to develop your own designs and to experiment with various materials.



CONTENTS

| | |
|---|----|
| NAME OF COMPONENT PARTS | 1 |
| FUNCTION OF MACHINE PARTS | 3 |
| SUMMARY OF WEAVING OPERATIONS..... | 5 |
| CALCULATING LENGTH AND NUMBER OF WARP THREADS..... | 6 |
| PREPARATION OF WARP | 7 |
| THREADING WARP ONTO THE ROYAL LOOM | 9 |
| SETTING YOUR KNITTING MACHINE ON THE ROYAL LOOM | 11 |
| THREADING WARP ONTO YOUR KNITTING MACHINE | 11 |
| PREPARATION OF THE WEFT..... | 13 |
| OPERATION OF PUNCH CARD MACHINES WHEN WEAVING | 14 |
| COMMENCING WEAVING | 15 |
| CONTINUING WEAVING..... | 17 |
| FINISHING | 20 |
| EXAMPLES OF PATTERNS USING PLAIN WEAVE..... | 21 |

NAMES OF COMPONENT PARTS

MAIN BODY

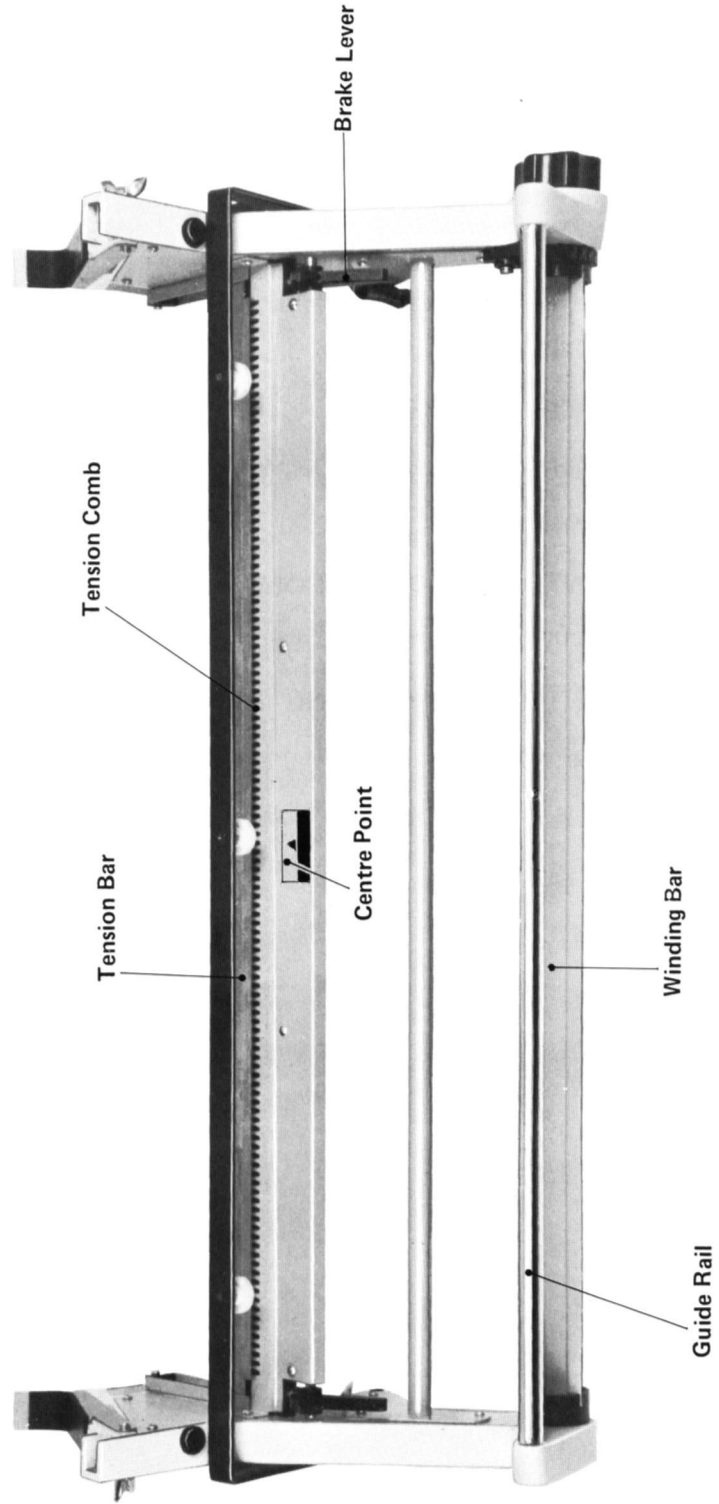

PARTS AND ACCESSORIES

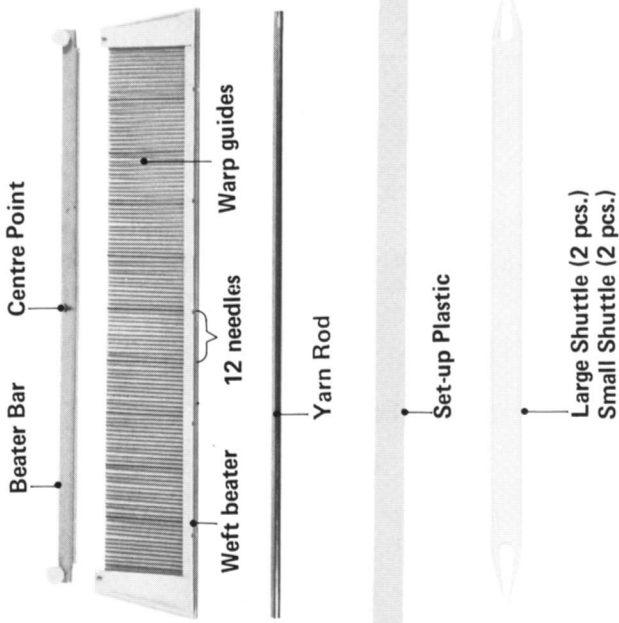
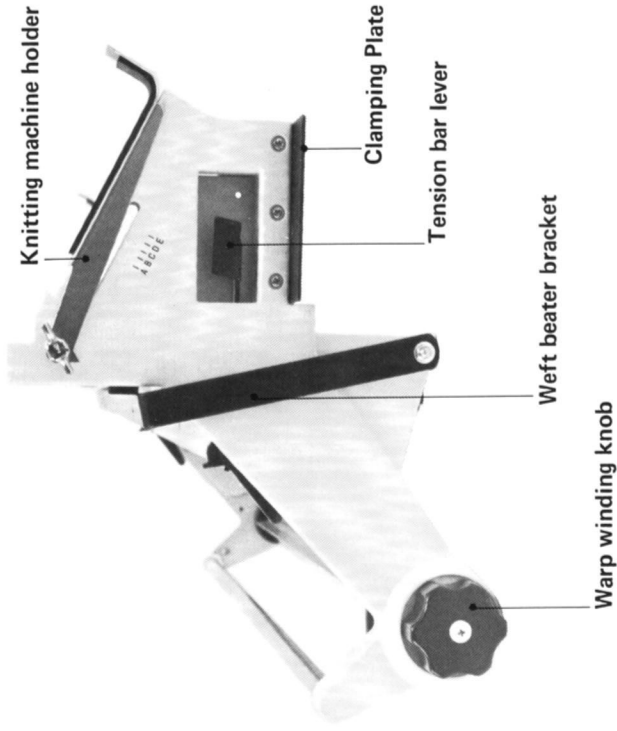

Table Clamps



Bobbin (20 pcs.)

SIDE VIEW OF MAIN BODY



FUNCTION OF MACHINE PARTS

WEFT BEATER

Beats down the weft passing through the warp threads.

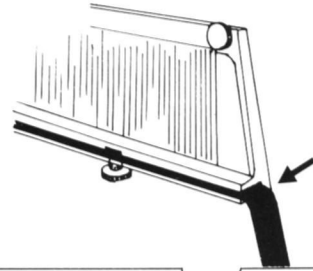

BRAKE LEVER

Tightens or loosens the warp threads passing through the tension comb.

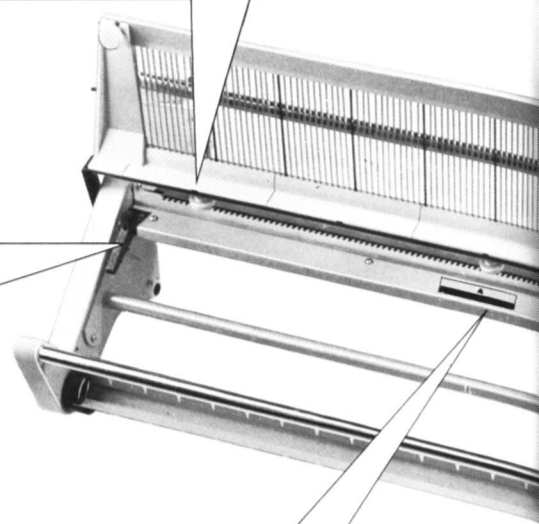
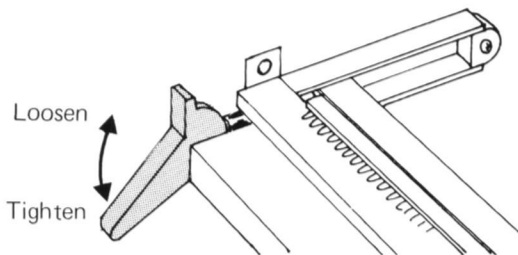

CENTRE POINT

Centre of main body and warp guides.

WINDING RATCHET

Prevents warp from unwinding.

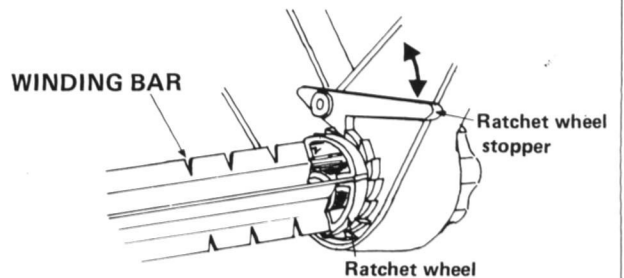

YARN ROD Removable.

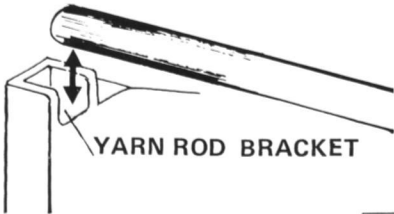

YARN ROD BRACKET

KNITTING MACHINE HOLDER

Adjust according to depth of machine bed.

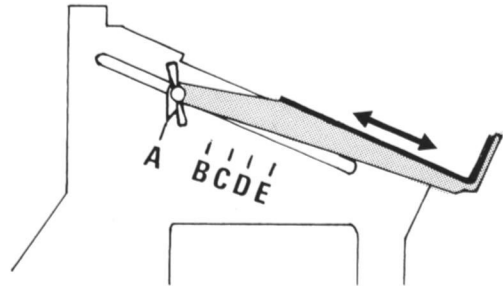

TENSION BAR LEVER

Used for removing tension bar.

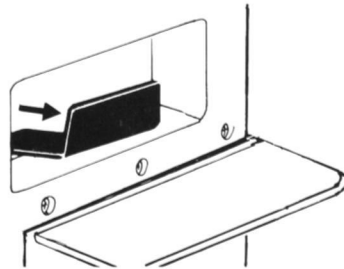

WARP WINDING KNOB

Used for adjusting tension of the warp threads.

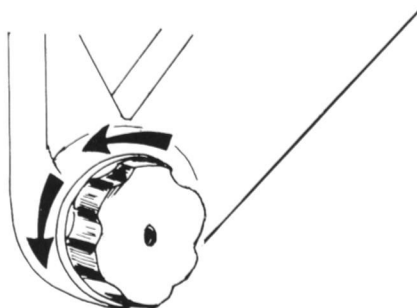

SUMMARY OF WEAVING OPERATION

To be used as reference only.

All operations are shown in greater detail in remainder of book.

1 PREPARATION OF THE WARP

Wind the desired length of warp onto bobbins.

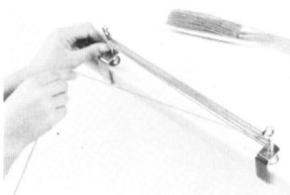

2 THREADING THE WARP ONTO THE ROYAL LOOM

Clamp the Weaver onto a table and attach the warp.

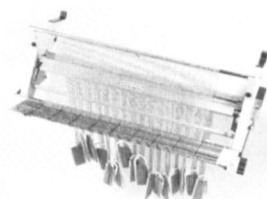

3 SETTING YOUR KNITTING MACHINE ONTO THE ROYAL LOOM

Set your punchcard machine onto the knitting machine holder.

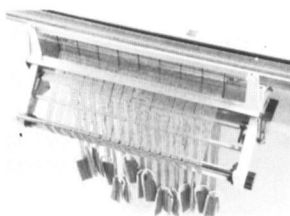

4 TIGHTEN THE WARP

Place warp threads onto knitting machine needles.



5 PREPARE THE WEFT

Wind a suitable length of yarn around the shuttle.

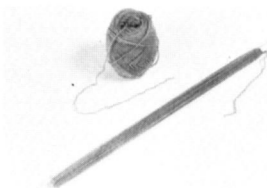

6 TO COMMENCE WEAVING

Insert punchcard into the knitting machine, select needles and insert set-up plastic.

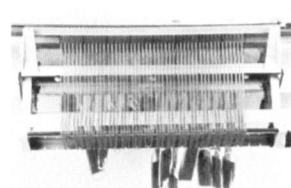

7 TO CONTINUE WEAVING

- *Select needles by carriage operation.
- *Pass shuttle through warp threads.
- *Push weft thread down with weft beater.

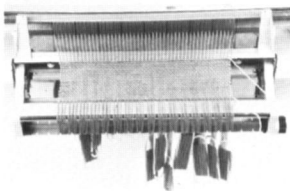

8 FINISHING

Sew in weft ends and knot warp threads.

CALCULATION OF THE LENGTH AND NUMBER OF WARP THREADS

The warp consists of a number of threads of equal length which are threaded vertically onto the ROYAL LOOM.

HOW TO CALCULATE THE LENGTH OF WARP THREADS :-

e.g. If completed length of woven article is to be 30 inches.
The completed length in inches = 30 inches.

PLUS

Shrinkage allowance in inches
(Divide completed length by 20) = $30 \text{ inches} \div 20 = 1.5 \text{ inches}$.

PLUS

Finishing allowance
(Always allow 20 inches)
Total measurement of Warp threads $30 + 1.5 + 20 = 51.5 \text{ inches}$.

HOW TO CALCULATE THE NUMBER OF WARP THREADS

e.g. If completed width of weaving required is 10 inches Completed width in inches = 10
Multiply completed width by 6 = 60
Therefore, 60 warp threads are required to give a completed width of 10 inches.

PREPARATION OF THE WARP

EQUIPMENT :- YARNS
BOBBINS
CLAMPS
SCISSORS

1. Fasten one Clamp to table as shown.

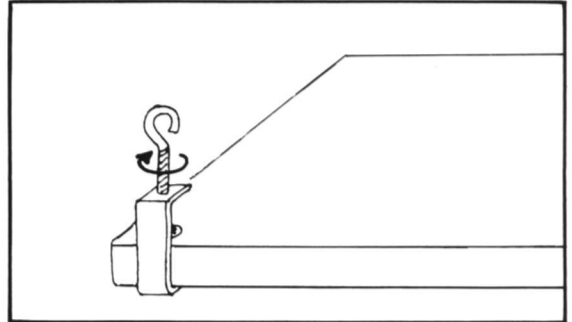

2. To prepare a Warp 36 inches long, fasten second Clamp 30 inches away from Clamp A.

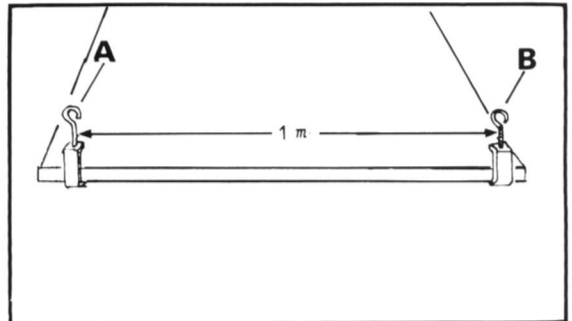

3. Starting at Clamp A, wind yarn around both Clamps 3 times, finishing at Clamp A.

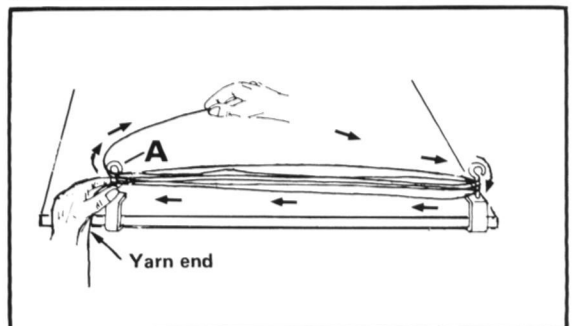

4. Cut through the yarn at Clamp A.

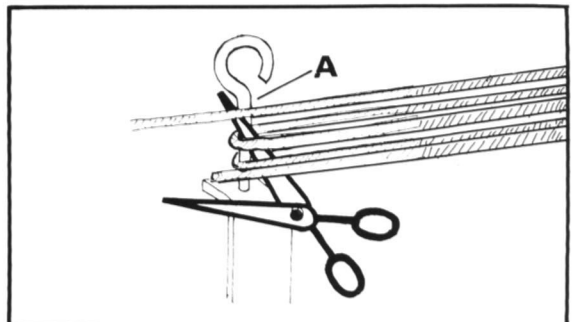

5. Take the center of threads (from Clamp B) and hook onto a Bobbin.

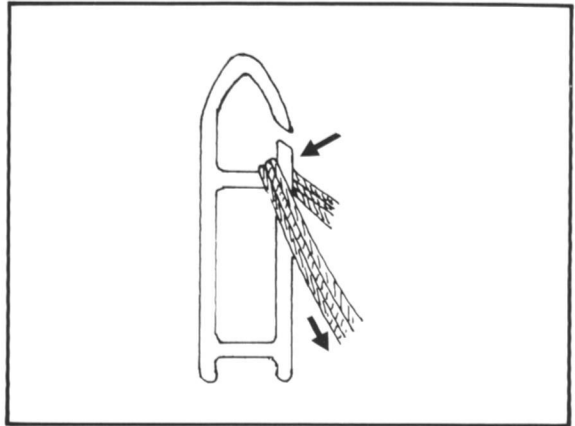

6. Wind the 6 threads onto the Bobbin, keeping them parallel. Leave the last 20 to 25 inches unwound.

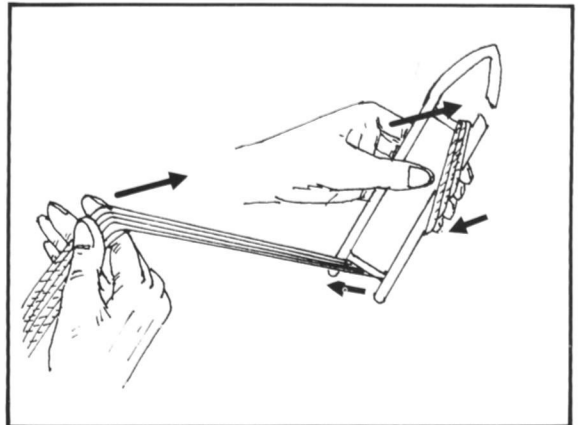

REPEAT STEPS 1 to 6 for the necessary number of Warp threads.

NOTE: The standard number of Warp threads is 6, but the number can be varied to more or less threads as is necessary.

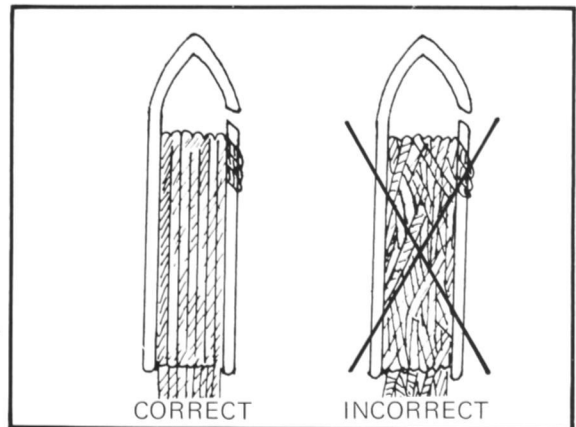

THREADING THE WARP ONTO THE ROYAL LOOM

1. Clamp the Loom onto the edge and approximately the center of a table.

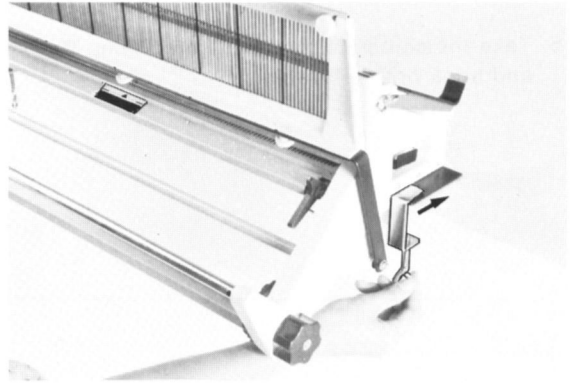

2. Remove Beater Bar, Tension Bar and Yarn Rod.

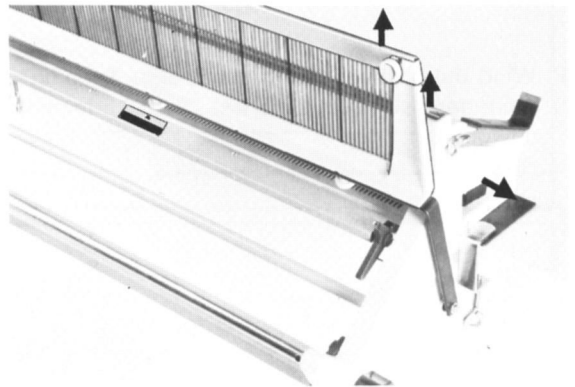

3. Pull the Weft Beater toward you until it clicks.

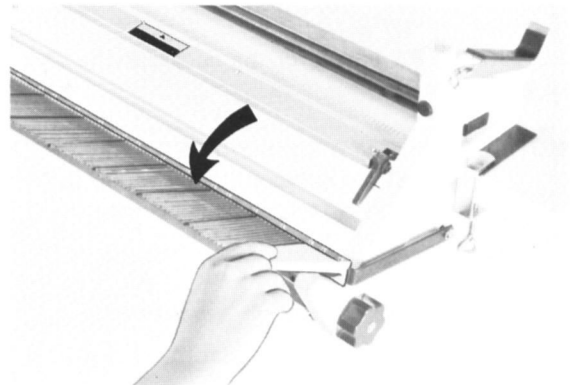

4. Use the Center Warp Guide as a starting point, and place one Warp thread between every Warp Guide.

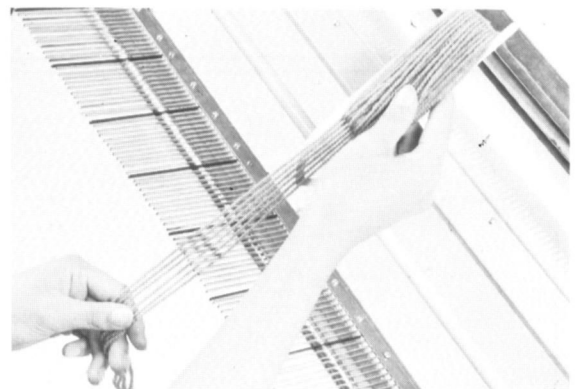

5. Pass the Bobbin between the Tension Comb. Place the thread from the central Warp Guide in the center of the Tension Comb. Place each Warp thread between every notch in the Tension Comb, keeping threads parallel.

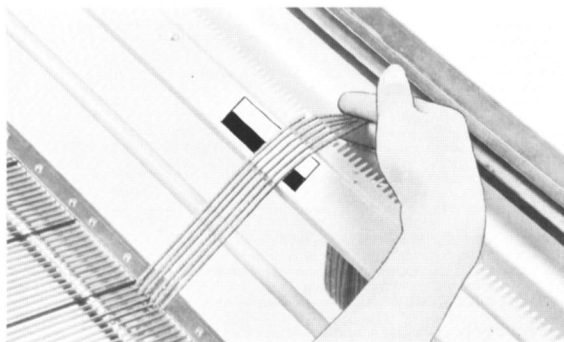

6. Continue threading Warp in the same manner, finishing with an equal number of threads at either side of the center point. Set Tension Bar by pulling it toward you and attach the Beater Bar.

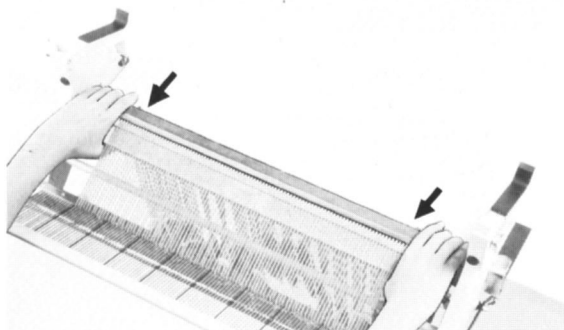

7. Lift Break Lever, knot Warp threads in groups of 6 and place in the notches of the Winding Bar.

(NOTE: Turn Winding Bar so that notches are vertical).



8. Pass the Yarn Rod underneath the threads (between Tension Comb and Weft Beater) and lift the yarn into position on the Yarn Rod Brackets.



9. Turn the Warp Winding Knob gently towards you to achieve a good tension. Push Brake Lever down to secure tension.

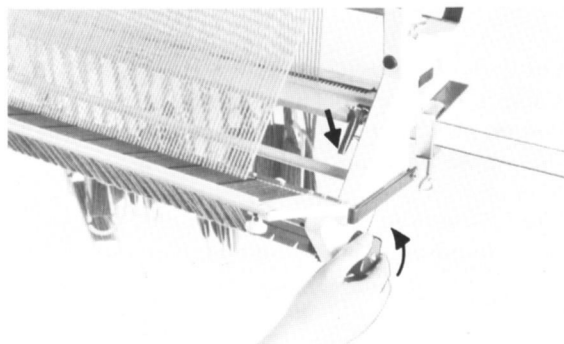

SETTING YOUR KNITTING MACHINE ONTO THE ROYAL LOOM

Before fitting Knitter onto Holder Bracket '1', set Pointer '2' according to your brand of machine and tighten screw. See Reference Table below for correct adjustment.

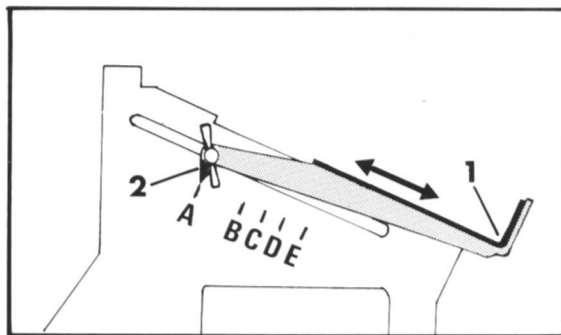

| BRAND | KNITTING BROTHER | STUDIO | TOYOTA | JUKI |
|-----------|----------------------------|-------------------|--------|--------------|
| SETTING | 'C' | 'B' | 'E' | 'A' |
| MODEL NO. | KH 840 KH 830 KH 820 | 324 326 328 | KS 787 | 2400 2500 |

THREADING WARP ONTO KNITTING MACHINE

1. Set your Knitting Machine on the Knitting Machine Holders and make sure it is central by aligning one needle each side of 'O' with one Warp Guide each side of center point.

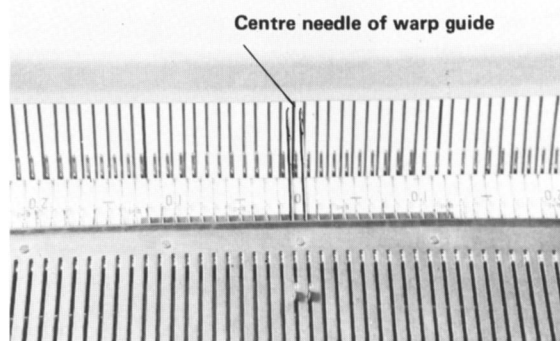

2. Lift Brake Lever. Using a Transfer Tool and starting at the center, pick up the Warp threads and place them onto the needles of the Knitting Machine.

(NOTE: Be sure to open all Latches of Knitting Needles before doing this.)



3. Remove the Yarn Rod, place it behind the Warp threads in the Tension Comb and replace it in the Yarn Rod Bracket.



4. Align needles in 'B' position using a Needle Pusher.
Check the tension of the Warp by hand.
Adjust loose threads by pulling Bobbins downward.
Push Brake Lever down and return the Weft Beater to the upright position.

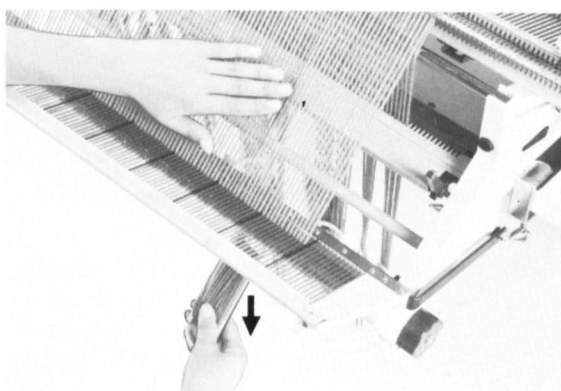

PREPARATION OF THE WEFT

EQUIPMENT :- YARN
SHUTTLE
SCISSORS

1. Hold the end of yarn onto the Shuttle with the thumb and wind yarn onto the Shuttle as illustrated.

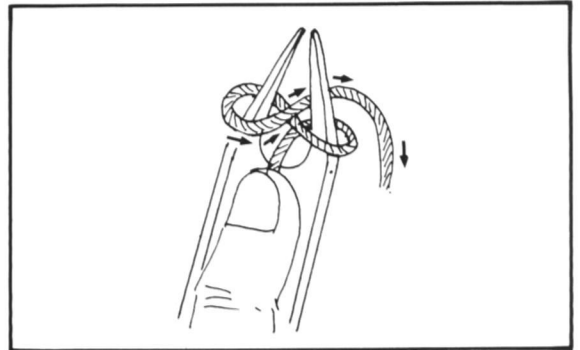
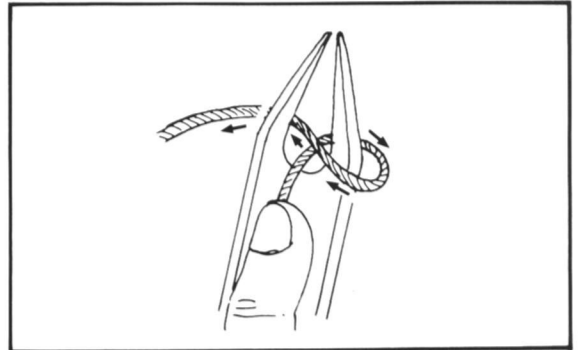
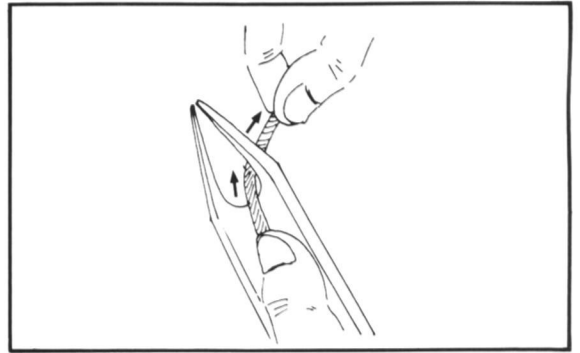

2. Continue winding yarn around the Shuttle until it is full.

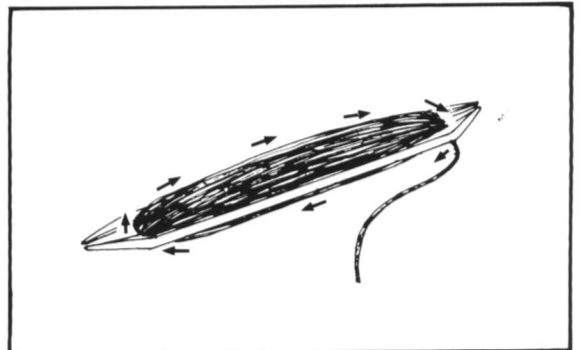

OPERATION OF PUNCHCARD MACHINES WHEN WEAVING

1. Insert basic Punch Card (FOR EVERY OTHER NEEDLE).
2. Set your brand of Knitting Machine according to the instructions below.

NOTE : Do not attach Sinker Plate or Brush assembly to your Knitting Machine Carriage.

| | |
|--|---|
| <p>KNITKING BROTHER MACHINES</p> <p>KH 840 KH 830 KH 820</p> | <ul style="list-style-type: none"> * Set Stitch Tension Dial to '0'. * Set left Lever of Carriage to Stockinette. * Set all center Buttons to normal position for Stockinette knitting. <p style="text-align: center;">— OPERATION OF CARRIAGE —</p> <ol style="list-style-type: none"> 1. Check Machine and Loom to see that everything is set correctly. 2. Select needles every row by pushing the Carriage one way and follow the movement of the Carriage by threading the Shuttle through the Weaving Loom Shed. |
|--|---|

| | |
|---|--|
| <p>STUDIO MACHINES</p> <p>324 326 328</p> | <ul style="list-style-type: none"> * Set Stitch Tension Dial to '0'. * Set Controls for Stockinette stitch. * Set Pattern Variation Knob to 'L'. <p style="text-align: center;">— OPERATION OF CARRIAGE —</p> <ol style="list-style-type: none"> 1. Set Cam Lever to '0' and push Carriage across needles for one row (Pattern is memorized). 2. Push handle of the Carriage backwards, raising the center (as you do when Carriage is jammed). . . and move across needles for one row. Alternate needles will be brought forward into 'C' position. <p>REPEAT Steps 1 and 2 for every row of Weaving Pattern.</p> |
|---|--|

| | |
|--|--|
| <p>TOYOTA MACHINES KS 787 JUKI MACHINES 2400 2500</p> | <ul style="list-style-type: none"> * Set Stitch Dial to '0'. * Set Levers as required for Pattern Knitting. <p style="text-align: center;">— OPERATION OF CARRIAGE —</p> <p>Same operation as KNITKING/BROTHER Knitters.</p> |
|--|--|

COMMENCING WEAVING

1. Select Needles to 'C' position as explained on Page 14.

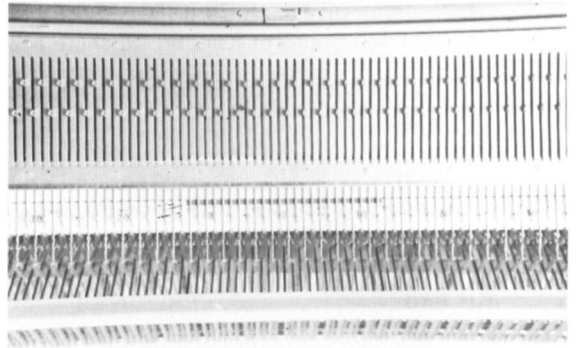

2. Thread set-up Plastic between the 2 sets of Warp threads.

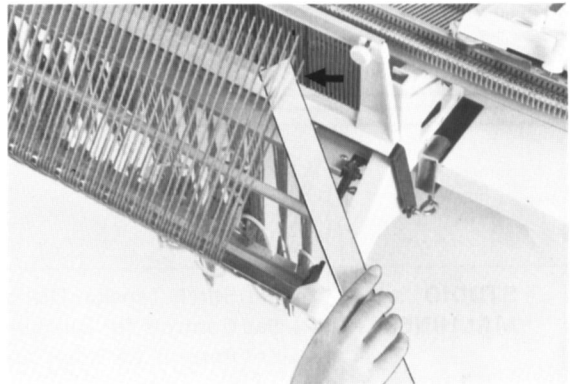

3. Push set-up Plastic down to position shown.

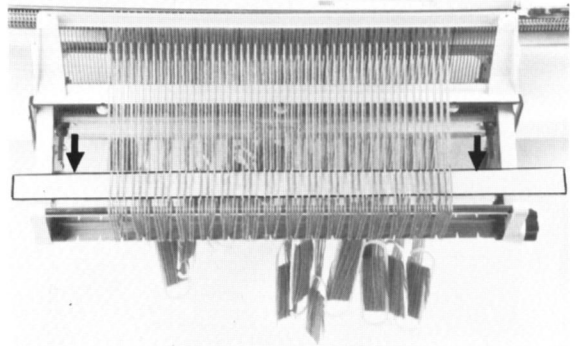

4. To weave first row, select the row of Pattern and thread Shuttle from the right between the 2 sets of Warp threads, leaving an end of about 6 inches.

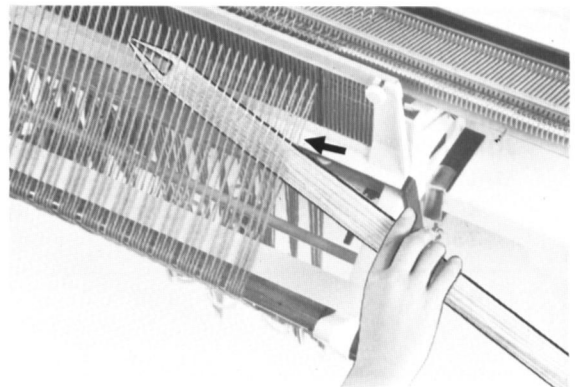

5. Pinch the Weft thread at the right edge of the Warp immediately above the set-up Plastic using your right hand. Place the Weft at an angle of approximately 20° from the set-up Plastic with the left hand.

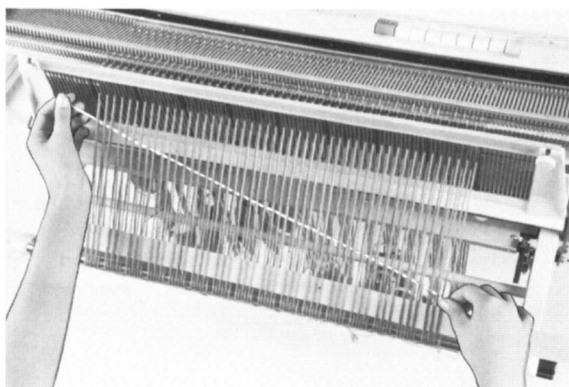

6. Hold the center of the Weft Beater Bar and pull it downward until the Weft is positioned parallel with the set-up Plastic. Return Weft Beater to the upright position.

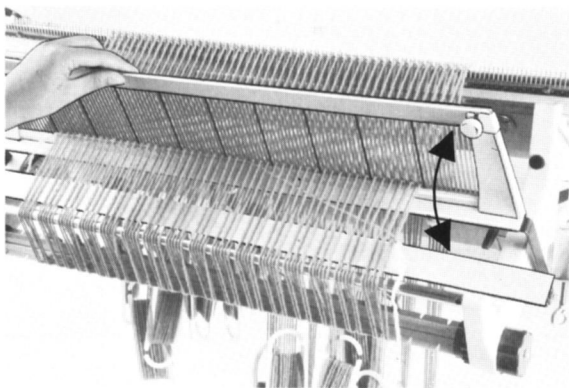

7. Select the positions of the Warp threads by moving the Carriage as required, then thread Shuttle between the 2 sets of Warp threads, moving it from left to right. The Weft should be taut, (but not too tight). Place Weft at the same angles as for the first row. Pull down the Weft Beater gently.



REPEAT THE OPERATIONS ABOVE.

1. Move the Carriage.
2. Pass the Shuttle through.
3. Gently pull down Weft Beater.

TO CONTINUE WEAVING

1. As you continue to weave, the space between the fabric and the Weft Beater (the Shed) becomes narrower. To widen the Shed, (enabling the Shuttle to pass more easily) wind the fabric around the Winding Bar.

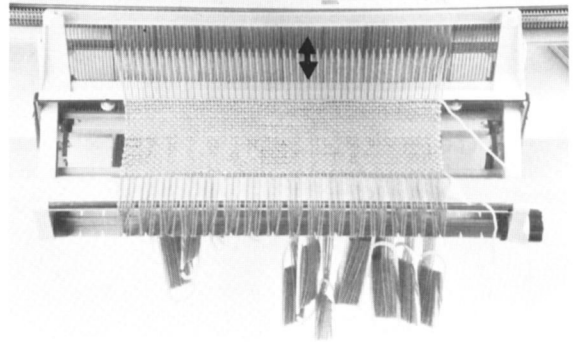

2. Unwind about 12 inches of Warp from the Bobbins.
3. Remove set-up Plastic by pulling it sideways.

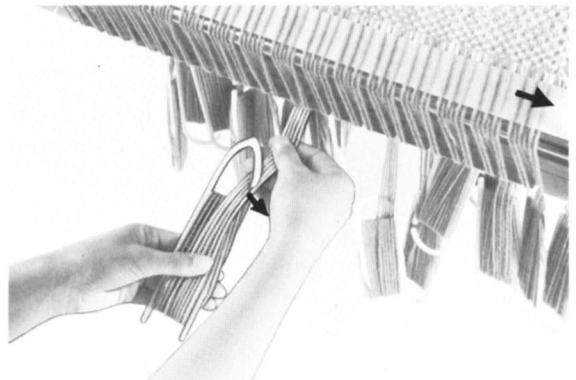

4. Bring needles into 'C' position from 'B' position using a Needle Pusher. Lift Brake Lever.



5. Place Shuttle behind woven fabric and holding Shuttle and fabric at both sides as shown, pull towards you, loosening the Warp approximately 4 inches.

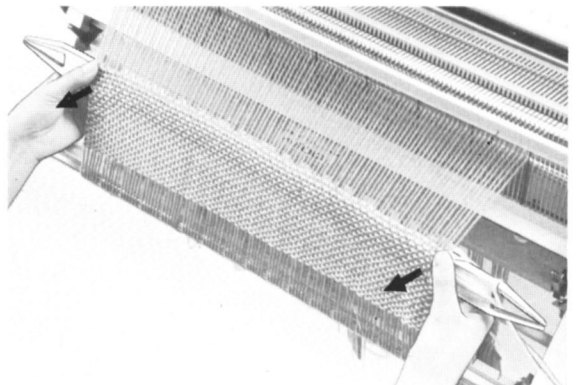

6. Turn the Warp Winding Knob until 2 inches of fabric is showing above the Winding Bar. Push the Brake Lever down and wind again until fabric is taut.

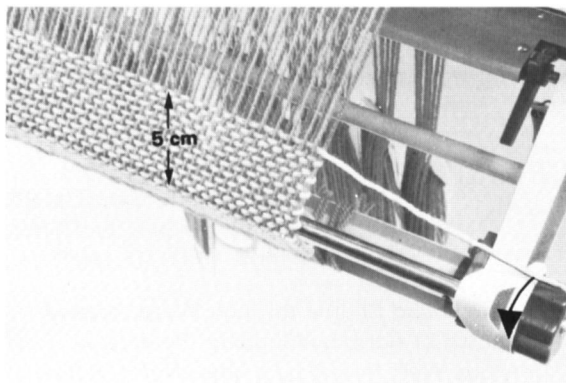

7. Check Tension of Warp by hand and continue weaving.

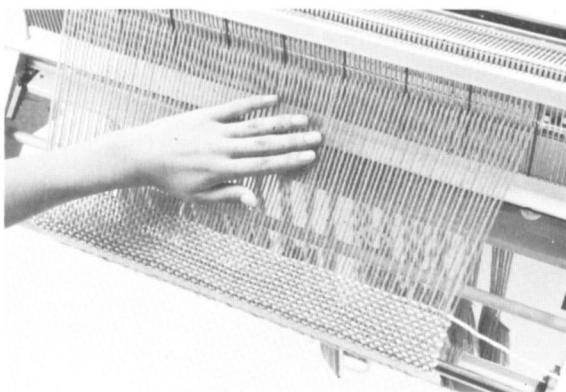

IF WARP TENSION IS UNEVEN

IF TENSION IS LOOSE :

Lift Brake Lever, pull loose Warp threads down by the Bobbin until they become even, then push Brake Lever down.



IF TENSION IS TOO TIGHT

Lift Brake Lever, pull tight Warp threads toward you until they become even, then push Brake Lever down.

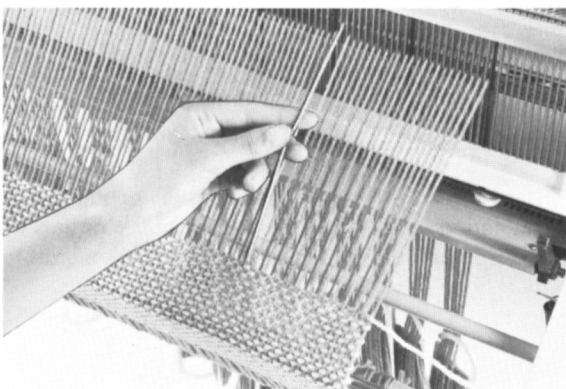

TO RENEW WEFT THREAD

1. Rewind Shuttle as shown on page 13.
2. Pass rewound Shuttle through Warp threads as shown at right, overlapping the ends of previous Weft thread by a little over 1 inch. Continue to weave.

NOTE: New Weft threads can be introduced at the selvedge as described on page 15, No. 4 and 5.

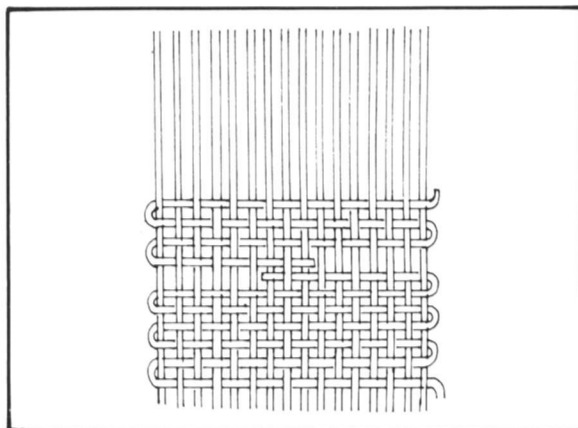

HOW TO CALCULATE LENGTH MEASUREMENTS

If for example, the finished length of woven fabric is to be 20 inches, weave 20 rows (pass Shuttle through Warp 20 times) and measure the length. If 20 rows measures 4 inches, the calculation will be as follows:

DIVIDE

Length of fabric (in inches required)=20

BY

Measurement (in inches) of 20 rows=5 ($20 \div 4 = 5$)

AND MULTIPLY this number by 20=100 ($5 \times 20 = 100$)

Therefore 100 rows of weaving will produce a length of fabric measuring 20 inches.

You can use the Row Counter of your Knitting Machine while weaving.

NOTE: For Studio machines only: weave until Row Counter shows double the required number of rows.

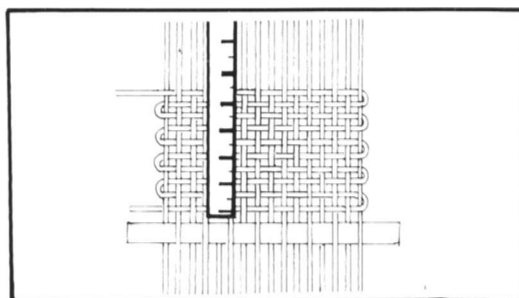

FINISHING

After completing the desired length of fabric, it is necessary to finish the Warp and Weft threads.

TO REMOVE FABRIC FROM THE ROYAL LOOM

- * Remove Warp threads using a Needle Pusher.
- * Remove Yarn Rod and Weft Beater Bar and release Tension Bar Lever.
- * Lift Warp from between Tension Bar and Tension Comb and remove the Weft Beater.
- * Lift Winding Ratchet, turn Winding Knob back and remove fabric from Winding Bar.

FINISHING METHOD / 1

1. Before removing fabric from the Loom, cut the Weft. Leave a length about double the width of fabric.
2. Thread Weft into a Tapestry Needle and stitch as shown in Diagrams 1-3 and fasten as shown in Diagram 4.
3. Finish the other end of fabric in the same way.
4. Cut Fringe to even length as required.

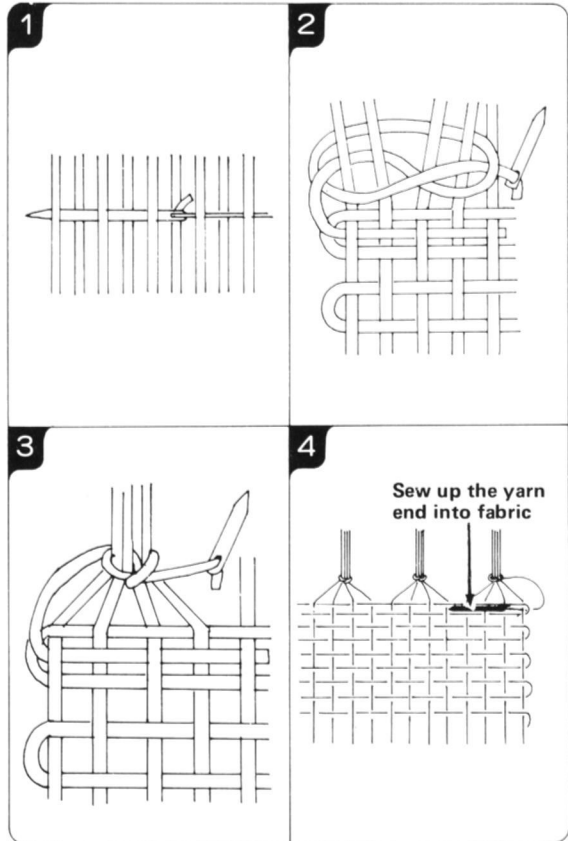

FINISHING METHOD / 2

1. Remove fabric from the Loom and cut Warp, leaving about 4 inches for Fringe.
2. Working in groups of 6, bind 5 threads with the 6th thread and fasten as in Diagrams 1 and 2. Cut Fringe to an even length.

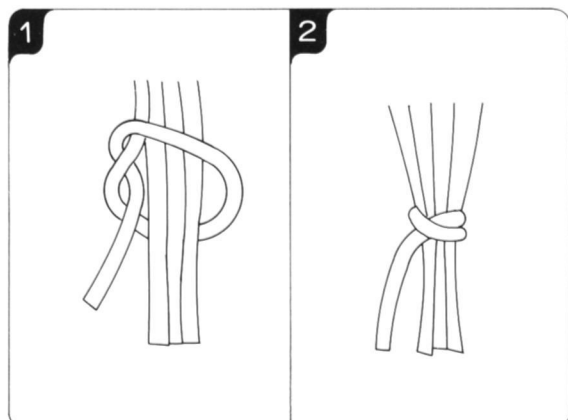

EXAMPLE OF PATTERN USING PLAIN WEAVE

Use basic Punch Card (1 hole, 1 blank alternately) supplied with ROYAL LOOM.

Example shows Patterns achieved by changing colors of Warp and Weft threads at even intervals.

| <u>WARP THREADS</u> | | | | | | | <u>WEFT THREADS</u> |
|---------------------|---------------------------|---------------------------|---------------------------|---------------------------|-----------|--|-------------------------------------|
| | | | | | | | All black |
| | | | | | | | 4 white 2 black x 4 + 4 white |
| | | | | | | | 4 black 2 white x 5 + 4 black |
| | | | | | | | 4 black 4 white x 3 |
| | | | | | | | 6 black 2 white x 3 |
| | | | | | | | 2 black 2 white x 3 |
| | | | | | | | All white |
| All white | 4 black 2 white x 3 | 6 black 2 white x 3 | 4 black 4 white x 3 | 2 black 2 white x 5 | All black | | |

Example showing Patterns achieved by changing color of Warp and Weft thread at uneven intervals.

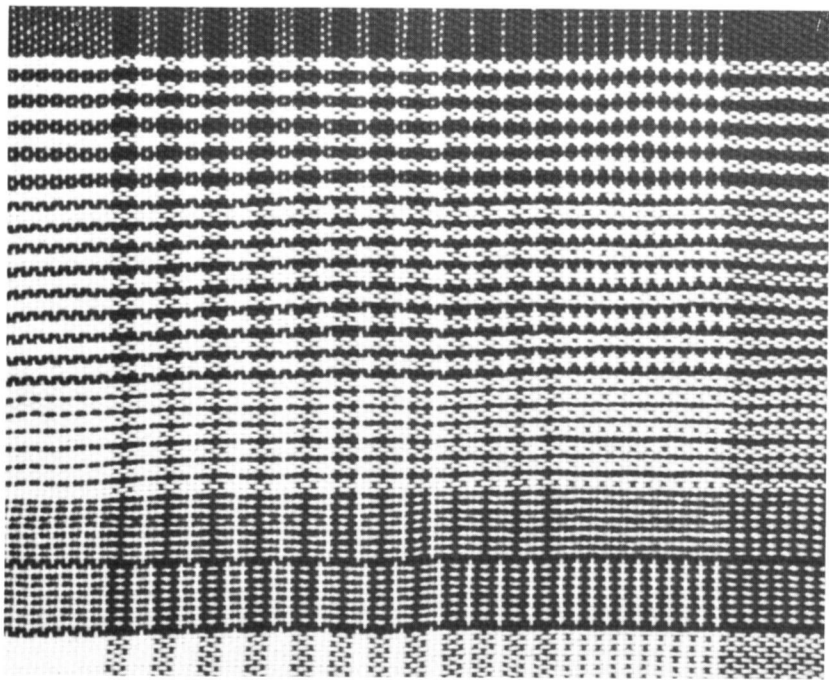

WEFT THREADS

All black

3 black
3 white x 5

2 black
3 white x 9

1 black
3 white x 7

1 black
1 white x 7

1 white
1 black x 7

All white

WARP THREADS

All white

3 black
3 white
x 4

2 white
3 black
x 3
+ 2 white

3 black
1 white
x 3

1 black
1 white
x 10

All black

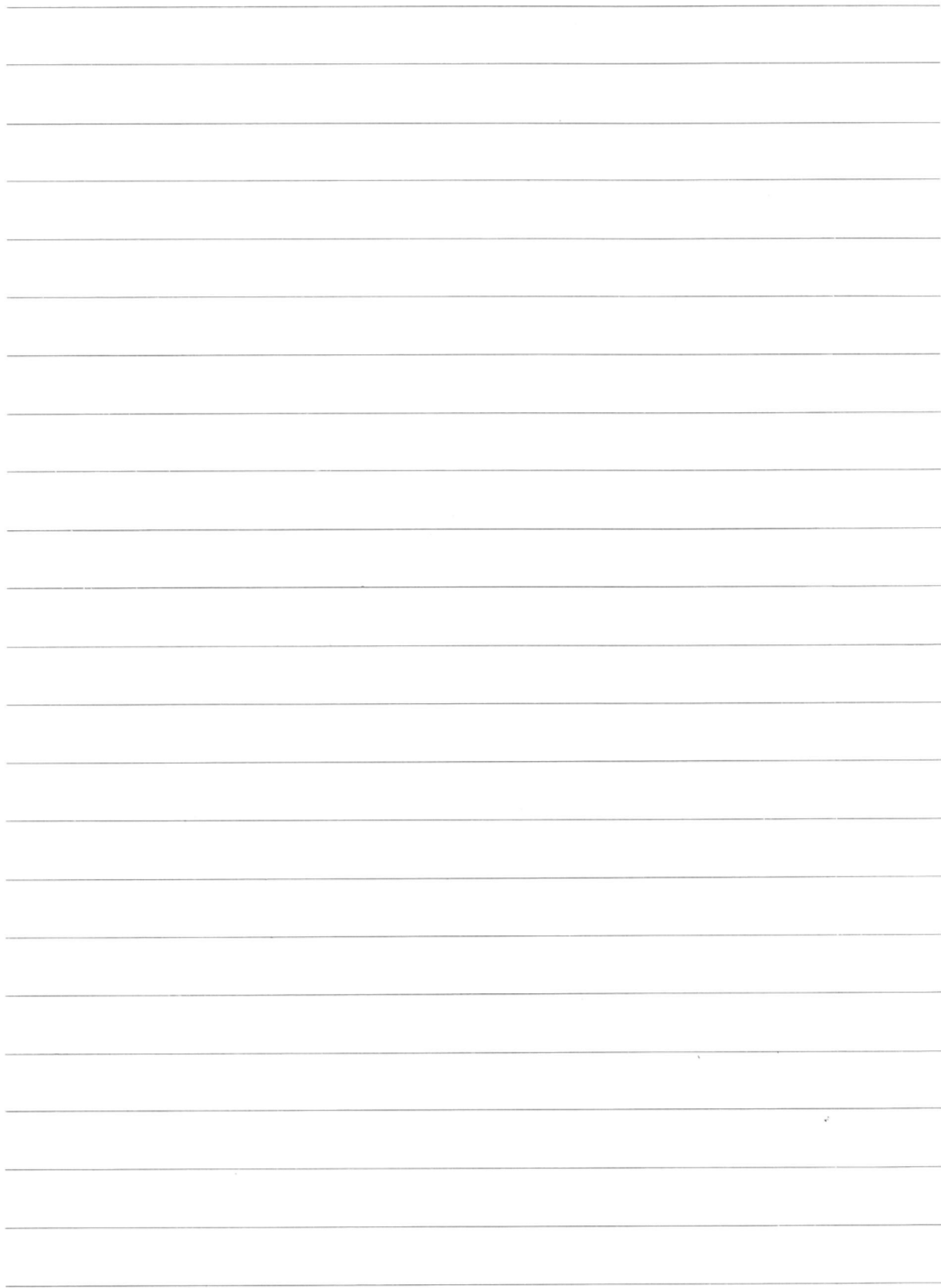



KNITKING CORPORATION
1128 Crenshaw Blvd.,
Los Angeles, CA 90019
Tel : 213-938-2077

Printed in Japan

