

# INSTRUCTION BOOK

---

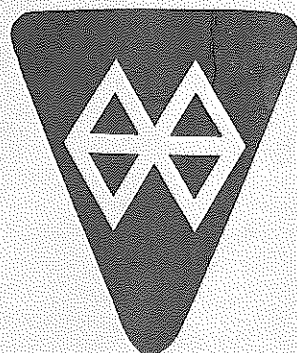

MANUFACTURER: MAX WULLIMANN, SELZACH/SWITZERLAND

## How to unpack your machine

Open carton and lift out your machine. Care should be taken to prevent the slide from running off the needlebeds, and that the two needlebeds do not separate.

If you find any transport damage, please notify your supplier immediately.

Ascertain that all accessories (see illustration page 4) are with the machine.

Separate front slide from back by pressing the unfastening lever upwards and pushing front slide sideways. Remove back slide from needlebed.

Remove front needlebed.

Bring the two built-in table clamps into working position and fasten firmly to table edge.

### Front Needlebed:

On both sides near the end underneath the machine you will find two screw holes, for 2 L-shape screws. These fasten the two needlebeds together. When the front bed is pushed fully home, the distance between the two beds should be  $\frac{1}{8}$  of an inch.

Before the slide is fitted to the machine, all needles must be pushed back into their rest position, as they would obstruct the movement of the slides.

Behind the slide you will find a fitting (part No. 24) for your automatic woolfeed (part No. 25). When this is fitted and secured by its screw, the machine is ready to knit.

It is essential to use a firm table as a shaky one can make knitting difficult. If your table has a drawer, we recommend you to remove while you are knitting, as it tends to make unnecessary noise.

Have all your tools and accessories, including scissors, paper and pencil within easy reach.

Before starting to use light coloured wool, brush machine thoroughly and run a length of light coloured wool through. This prevents dark wool fragments from showing on your knitting.

It is always advisable to knit a test piece before you start to knit a garment. Repeat the test when you have to buy more wool, even if it is the identical brand and shade. There are always minute difference due to spinning, dyeing, etc., which may alter the texture. Before counting rows and stitches, give your test piece time to settle.

As you will note from the illustrations in this book, your machine knits a perfect cast-on edge. This simplifies the unwinding of garments and re-use of wool.

Experiments have shown that quality wool can be knitted up to 20 times without any deterioration. This also shows that it pays to use best quality wool, especially for children's wear.

On page 17 you will find maintenance instructions for your machine and a fault finding table.

At the end of the book you will find an alphabetical index of terms and abbreviations with their reference and page numbers.

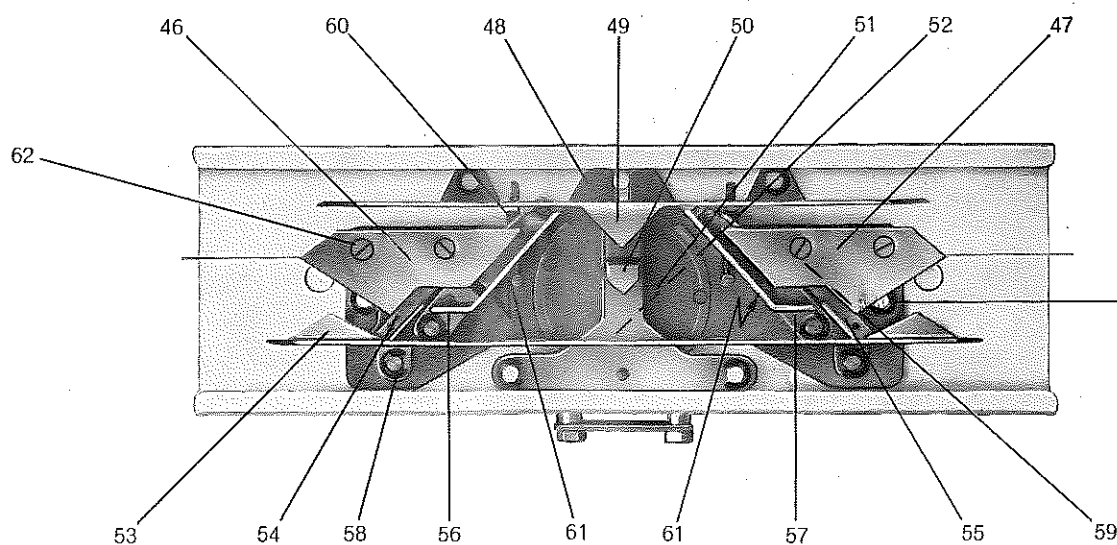

- |    |                                    |    |                           |
|----|------------------------------------|----|---------------------------|
| 46 | Left hand fixed cam                | 56 | Large movable-cam (left)  |
| 47 | Right hand fixed cam               | 57 | Large movable-cam (right) |
| 48 | Movable-cam mounting               | 58 | Small spring clip         |
| 49 | Centre-cam                         | 59 | Large spring clip         |
| 50 | Stitch-dropping preventer          | 60 | Cam mounting spring       |
| 51 | Cam position-selector disc         | 61 | Movable-cam spring        |
| 52 | Tension control plate (beneath 51) | 62 | Fixed-cam screw           |
| 53 | Lower cross bar with fixed cams    | 63 | Large washer              |
| 54 | Small movable-cam (left)           | 64 | Small washer              |
| 55 | Small movable-cam (right)          |    |                           |

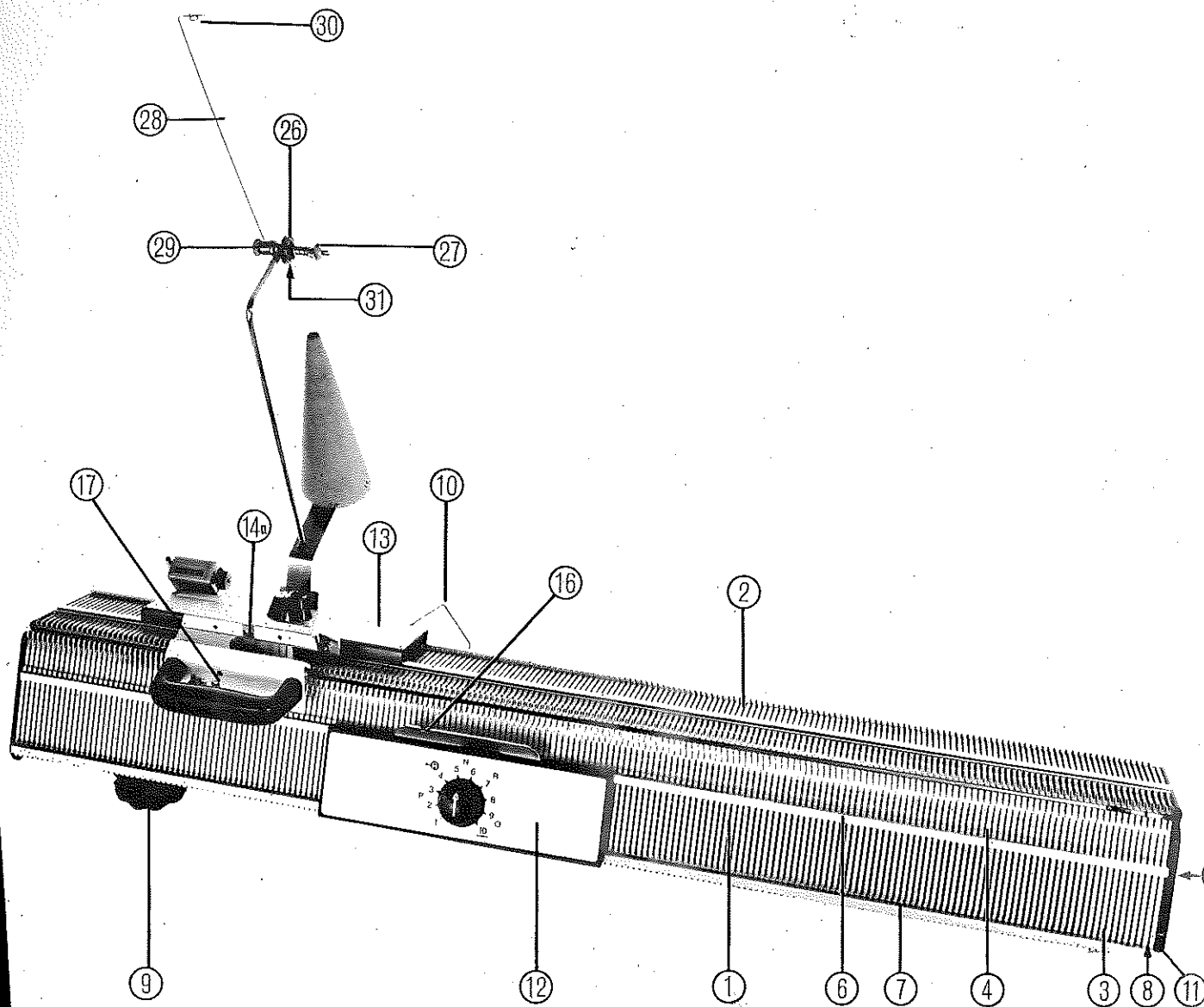

#### NEEDLEBED

- 1 Front needlebed
- 2 Rear needlebed
- 3 Needle grooves
- 4 Latch needle
- 5 Holding spring (under 6)
- 6 Upper slide rail (numbered)
- 7 Lower slide rail
- 8 Slide rail fastener
- 9 Racking wheel
- 10 Row counter trip
- 11 End cap

#### SLIDE

- 12 Front slide
- 13 Rear slide
- 14 Connector plate for the two slides
- 14a Wool guide
- 15 Unfastening lever
- 16 Lever notch
- 17 Fitting for stocking stitch bar
- 18 Handle
- 19 Stitch size control
- 20 Stitch size dial
- 21 Stitch type control
- 22 Row counter
- 23 Latch-opening brush

- 24 Fitting for wool feed carrier

#### WOOL FEED CARRIER

- 25 Upright
- 26 Wool brake
- 27 Tension screw
- 28 Tension wire
- 29 Tension screw for tension wire
- 30 Tension wire eye
- 31 Wool channel
- 32 Cone holder

#### ACCESSORIES

- 33 Casting-on comb (2 parts)
- 34 Side weights
- 35 Wool cones
- 36 L-shape screws
- 37 Large key spanner
- 38 Small key spanner
- 39 Needle selectors
- 40 Needle setter
- 41 Transfer tools
- 42 Multi-transfer tools
- 43 Stocking stitch bar
- 44 Spare needles
- 45 Oil can

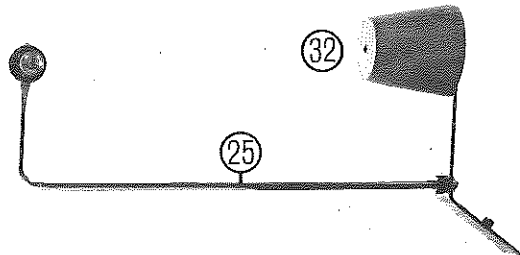
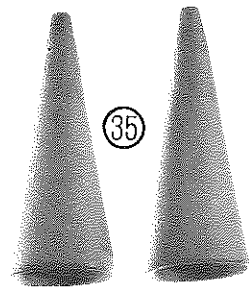
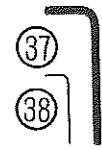
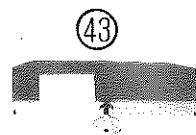
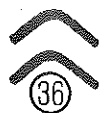
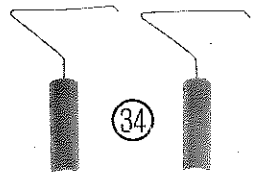
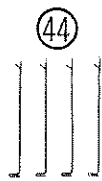
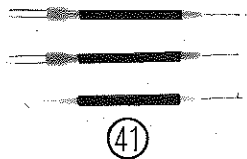
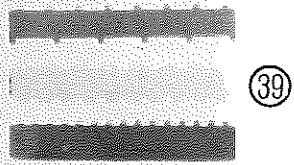
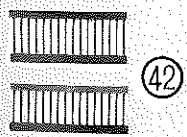
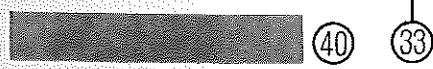
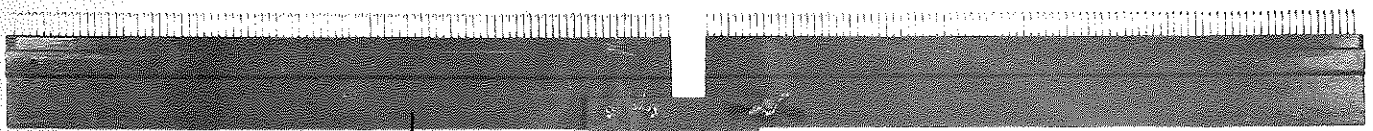
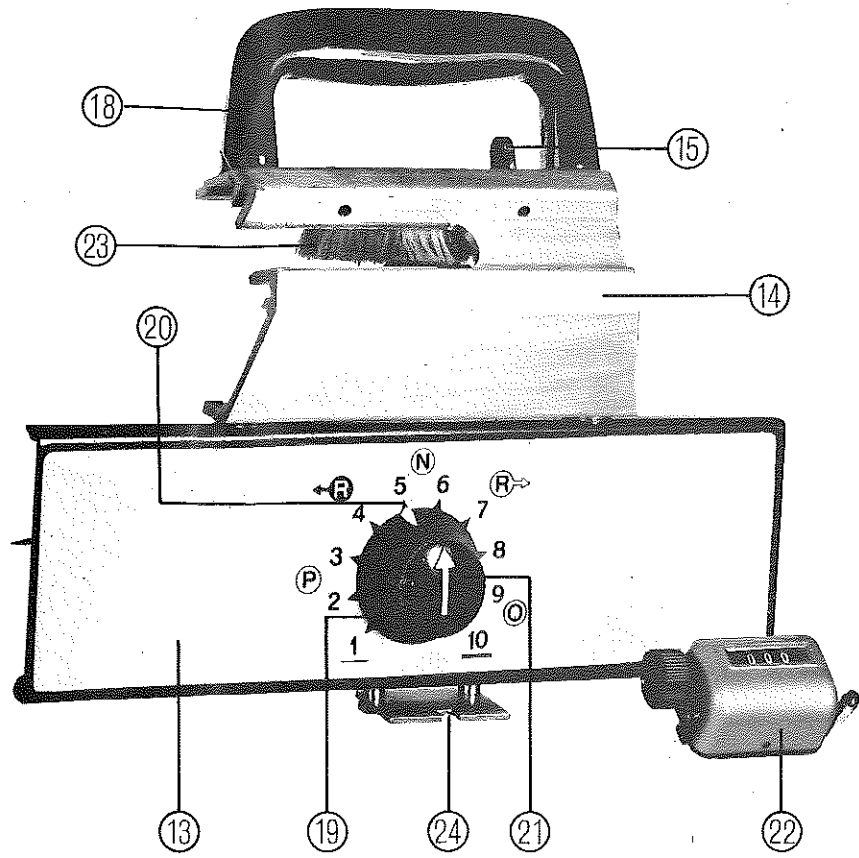

## The four needle positions

- R.P. = Rest position needle is out of action. Needle foot rests against lower slide rail.
- W.P. = Working position. Needle knits. Please observe the needle heads are just visible above the needle grooves.
- U.W. = Upper working position. This is used for certain knitting operations. Needle heads are visible with open latches.
- H.P. = Holding position. Needle temporarily excluded from operation — similar to slipping a stitch in hand knitting.

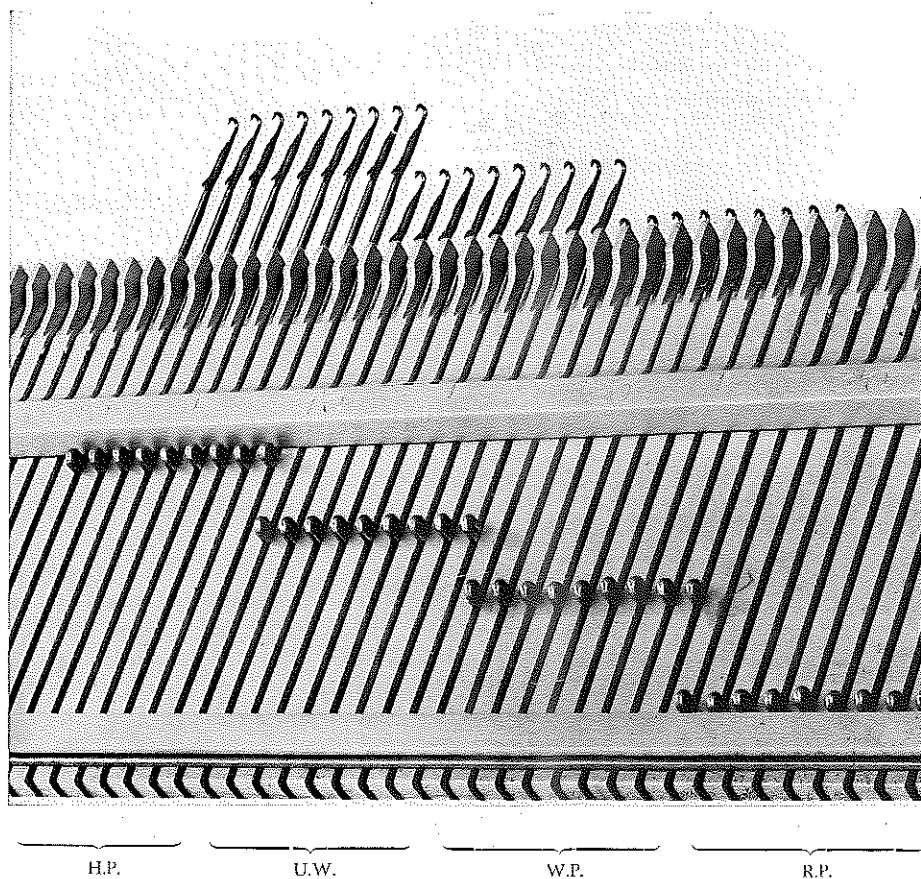

**Important:** These four needle positions are described R.P., W.P., U.W. and H.P. in the following instructions.

## The slide (12 and 13)

The control knob on the slide is divided into two independent control discs. The stitch size control (below) (20) determines the size of the stitch. The dial is divided into 10 stitch tensions from one — small, close stitch with fine wool, to ten — extremely large stitch with thick wool, or for open stitch effects. 3-ply wool should be knitted on 4 or 5 (ribbing), or on 7 or 8 (stocking stitch).

The stitch type control (21) determines the type of knitting done. If the arrow points to:

- O = the needles do not knit.
- N = the machine produces normal rib or stocking stitch.
- R = gives circular knitting in stocking stitch.
- P = it produces fisherman's rib (patent).

See last page for abbreviations

For a semi-patent effect (single-Fisherman's rib) the arrow of one slide points to N, that of the other to P.

**Important:** Before knitting make sure that both controls are in the right position.

The upper slide rail is numbered according to the number of machine needles, from the centre (0) to the sides. This simplifies the garment size control. The centre of your knitting should always be on 0.

The Racking Wheel (9). The front needlebed can be racked over seven needles for diagonal designs and a great number of interesting effects.

If the wheel is turned to the extreme left, the needles are facing each other on both beds (2 positions) and this position is therefore suitable only for rib patterns in which only every other needle is used.

This  $\frac{1}{2}$  position is the basic position for circular knitting. In this case **all needles** knit, but only those of one bed at a time.

**Important:** If all needles work and face each other in the  $\frac{1}{2}$  position the control knob of each slide must point to R as otherwise the needles will collide.

**The wool feed** (25—32) ensures a perfectly even flow of wool and even knitting texture.

**The cone** (35). The yarn should only be wound on the lower part of the cone and should not be too tight. Leave about  $\frac{1}{2}$ " free at the bottom, so that the yarn cannot slip off. The cone is put on the cone holder, (No. 32) for operation.

**Threading.** Bring your wool end from the cone and place between the two discs of the wool brake (26) and into the wool channel, then through the tension wire eye (30) and through the wool guide (14a) between the two halves of the slide.

The tension wire should always come to rest in a horizontal position when knitting and should never point upwards.

The tension screw (27) must be tightened or loosened according to the thickness of the wool to ensure free running. With very thick wool the tension wire fastening screw (29) should be loosened. The wire should then be turned slightly back, away from you. The tension screw should then be fastened again.

The row counter (22) counts the knitted rows automatically with every movement of the slide. With circular knitting it counts two rows for each round, and this has, of course to be allowed for. With a closed cast-on operation completed, return Row counter to 000 before you commence knitting.

III. 2

### The comb (33)

The cast on comb forms the cast on edge and also acts as weight. The weight is essential for a good knitting operation as it pulls the knitting down evenly and prevents dropping stitches. The comb consist of two halves which are the same width as the needlebed, when joined.

The comb is hung into the cast on stitches immediately after the first row (see page 8).

The side weights (34) should be used when the side stitches require some additional tension. They should always be used in every case when every other needle only is in operation for circular, half circular or single bed knitting.

#### The tools (41)

The single and double transfer tools, the multi-transfer tools and the latch-hook tool are used for increases, decreases, finishing edges and for patterns.

#### The Needle Selector (39)

The needle selector is used to bring the needles into the required position for setting up the machine both initially and in pattern work.

#### The Needle Setter (40)

The needle setter has a width of 40 needles, (the 40 stitches of the stitch test), and is used for setting up the machine in every needle work.

#### The Slide Rail Fastener (8)

The two slide rail fasteners secure the four slide rails. If they are removed, the rails are released and can be moved sideways (they should always be moved to the right).

#### The Stocking Stitch Bar (43)

This is used when knitting on one bed only.

### Formation of stitches (III. 3)

The needle is brought forward from position I to II. The stitch will open the needle latch and clear it. At this moment the open needle hook picks up the wool III. As the needle moves backwards, the latch is closed and a new stitch IV is formed.

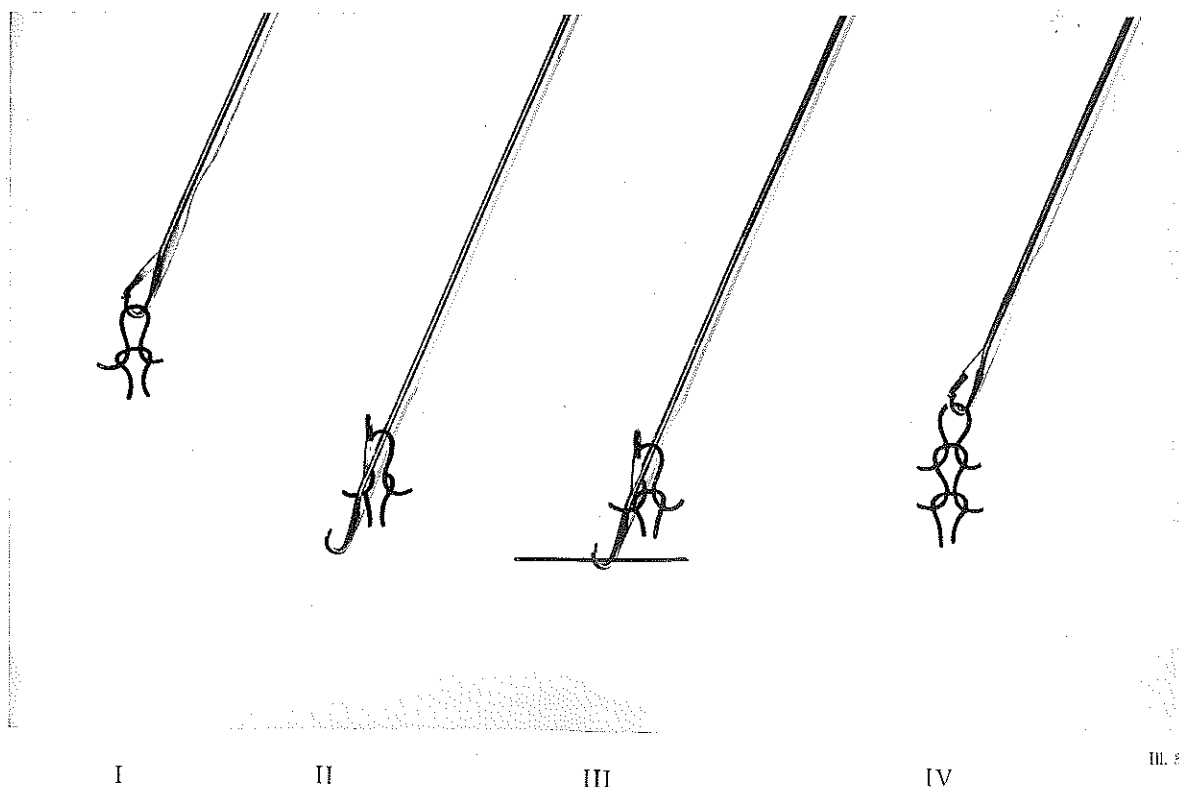



## Needle selection

Set machine for K 1, P 1

R.B.	N	.I.I.I.I.I.I.I.I.I.I.I.I.I.I.I	R.W. on 1/2.
F.B.	N	I.I.I.I.I.I.I.I.I.I.I.I.I.I.I	

for K 2, P 2

R.B.	N	II.II.II.II.II	R.W. on 1
F.B.	N	I.II.II.II.II	

- F.B. = Front bed.
- R.B. = Rear bed.
- N. = Arrow on stitch type control points to N.
- I. = Needle in working position.
- = Needle in rest position.

With K 2 P 2 the racking wheel is turned to No. 2 to show the following pattern for the cast on row.

R.B.	II.II.II
F.B.	II.II.II

As soon as the cast on comb is in position, turn racking wheel to No. 1 and leave it there.

**Important:** The outside needle on your left should always be on your front bed, the outside needle on the right should always be on the rear bed.

**Setting for Circular:** (Both beds must be on white R, or both beds must be on black R)

with all needles	R.B.	R	IIIIIIIIII	}	Cast on — RW on 1 Knit on 1/2
	F.B.	R	IIIIIIIIII		
	R.B.	R	I.I.I.I.I.I.I		
every other needle	F.B.	R	I.I.I.I.I.I.I		

The setting for semi-circular (horse shoe knitting) is the same, but after each completed row (two movements of the slide) the stitch type control must be changed from R black to R white and vice-versa.

## Double bed cast on

Before casting on the slide is always on the rt. hd. side. Select needles. Set both stitch type controls on N. Push slide over needles twice to line them up before threading wool (See page 6). Hold the wool end underneath the needle beds and bring slide slowly to the left, thereby forming a row of cast on stitches into which the weighted cast on comb is hung. (Ills. 4.)

Ill. 4

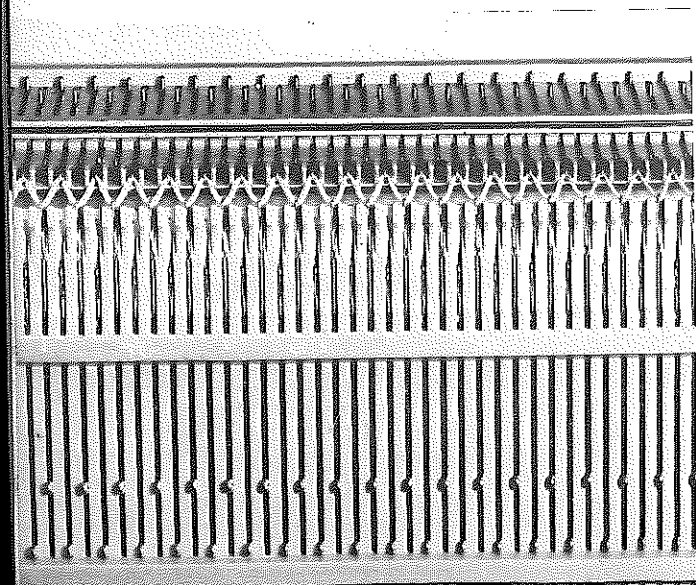

Hang comb symmetrically, so that both sides are weighted equally, i. e. the middle of the comb should correspond with the middle of the cast on row.

Set controls on R white and knit 2 circular rows (4 rows with thick wool). Return row counter to 000, controls to N and knit.

Each row must be completed and it should be ensured that the last needles complete their operation before turning back with the slide. Never turn back without completing the row, not even without wool nor with the stitch type control pointing to 0.

Do not bring your slide too far over the end stitches, otherwise the tension wire will lift too high and disturb the feeding of wool. The stitch size dial should only be changed when a row is completed.

### **Circular knitting:**

Needles on each bed knit plain or purl respectively, to form a hose shape with a plain exterior and a purl interior. This allows only patterns which are suitable for plain knitting, e. g. holes etc., Both dials on R.

The stitch size control is normally set 3 numbers higher than for ribbing. For needle position see page 8.

### **Semi-circular knitting**

This is suitable for extremely wide garments. Change control after every two rows as described. With a starting position with the slide on the right hand side the stitch type control should point to R. black. If you start with the slide on your left, you must point the control to R. white.

R. black = clockwise.

R. white = anticlockwise.

With circular knitting it is better to use side weights.

### **Fisherman's Rib (Patent)**

Needle position K 1 P 1. Both controls on P.

### **Single Fisherman's Rib (Half Patent)**

Also K 1 P 1. Control P on one bed, N on the other, but the stitch size control on the bed with N should be one number higher than that on the other.

### **Racking (page 6)**

This is only possible with basic ribbing patterns, and not with circular knitting. When racking, the stitch size should be set 2 numbers above the normal size without racking.

Patterns which require gradual racking over a number of needles should be started with the racking wheel on No. 1.

## **Special instructions**

III. 5

By pulling the wool upwards, the row last knitted can be undone as in illustration 5. The wool must never leave the wool guide during knitting as stitches would otherwise drop. A new cone is best started at the beginning of a row. It is sufficient to hold the two wool ends together underneath the machine, until the first few stitches are completed. When the piece is finally taken off the machine, the wool can be knotted and the ends cut. The knot becomes part of the edge and is not visible.

### **Taking off without securing stitches.**

Unthread and break wool. Hold middle of comb with one hand. Push slide across needlebed, thus releasing the knitting.

Picking up dropped stitches (illustration 6).

Loosen L-shape needle bed securing screws and pull FB towards you as far as possible. With your working hook pick up plain stitch from front, purl stitch from rear.

See last page for abbreviations

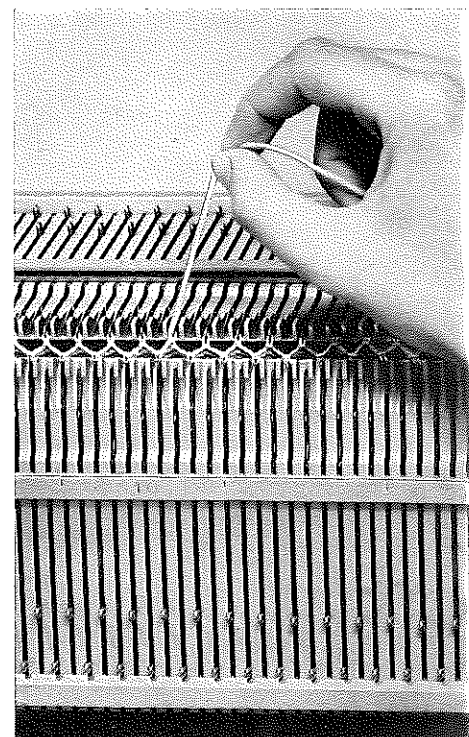

### Transferring needles with Multi-Transfer Tool.

Illustration 17 and 18 show how stitches are transferred from front to rear needlebed. Insert Multi-Transfer tool into latch needles (illustration 7). Pull needles out first and then push them home. The stitches are now held on the Multi-Transfer tool. Now transfer stitches to rear bed needles.

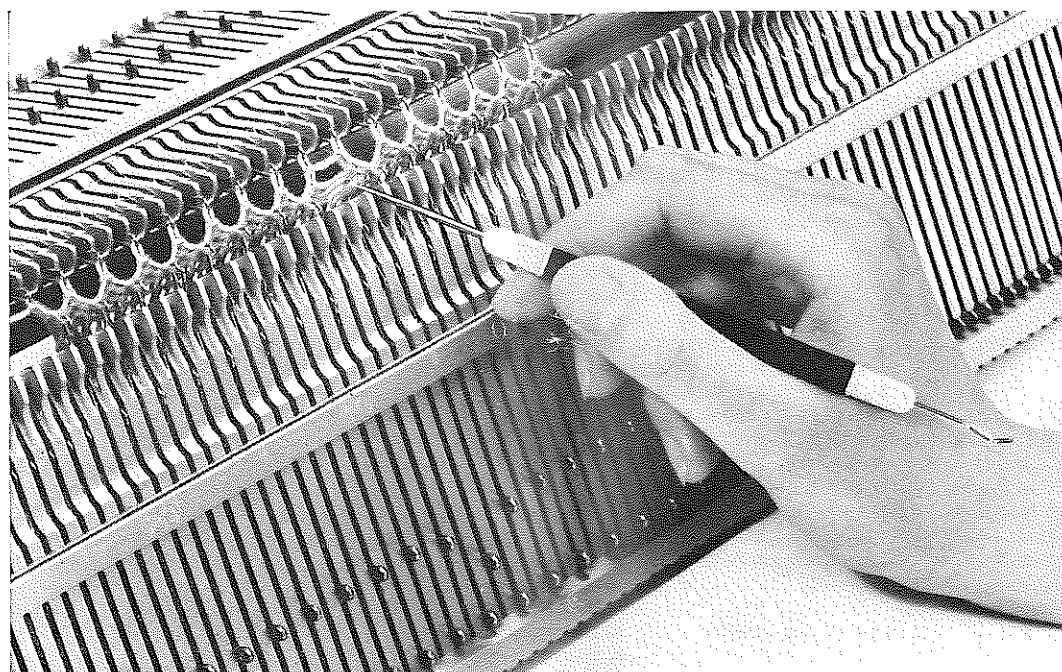

III. 6

**Casting off.** This is done in the same way as decreasing. (Page 11.)

**Use of the holding position.** (For shaping shoulders etc.)

Start with slide on the right. On the left bring the required number of needles into H.P. Knit a row and bring an equivalent number of needles into H.P. on the right. The needles in the H.P. position are brought back into the working position in small groups starting with the inner needles. It is recommended that the wool be put round the middle of the H.P. needle nearest the centre in order to avoid holes.

III. 7

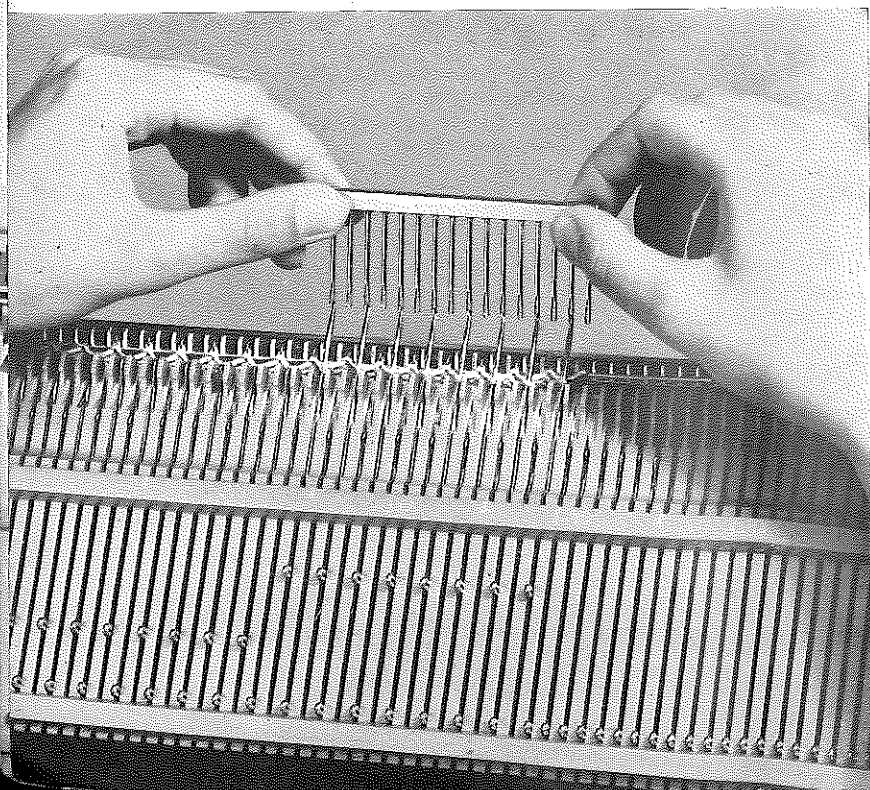

### Horizontal Button Holes and Pocket Holes etc. (Illustration 9)

Put a number of needles equivalent to the width of the button hole into the upper working position (U.W. page 5) stitches behind the open latches. Knit a short length of wool (if possible a contrasting shade) in by hand, then bring needles back into working position.

When the piece is finished and taken off the machine, pull out the short thread and finish button hole. It is sufficient to pass the wool through the open stitches twice, then finish with button hole stitching. (Illustration 9.)

With larger openings, stitches can be knitted off with hand needles or crocheted off with the latch-hook tool. In the case of pockets, they can be transferred to the machine to knit the pocket-interior.

See last page for abbreviations

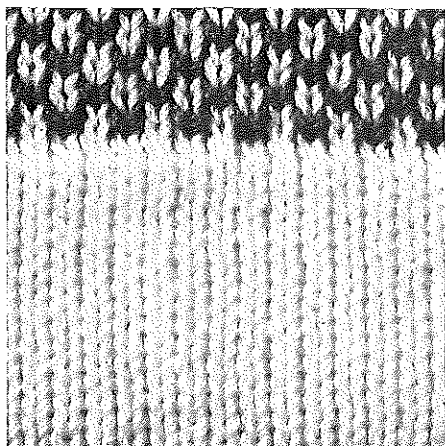

III. 8

When doing this, remember that with single bed knitting you always face the reverse side of the knitting.

**Vertical Button Holes.** (Illustration 10.)

Slide on right hand side. While you knit on the right of the opening, leave the left hand side in holding position (H.P.). You finish the last row with the slide on your left. Break the wool and put the right hand side needles into H.P.

Now put the needles on the left in Upper Working Position (U.W.) Thread wool and correct row counter, knit the left hand side of the opening, return all needles to U.W. and continue.

You are recommended to use side weights and return them to the top frequently. Vertical button holes often look untidy if they are not finished by button hole stitching.

**Larger Vertical Openings.** (Illustration 19.)

As vertical button holes.

**Shoulder Shaping.**

For shoulder shaping needles are gradually put into H.P. (see page 10 = use of holding position).

**V Shape.** (Illustration 20 and 21.)

These are knitted like vertical openings, but decrease as required.

**Single Stitch Decrease.**

With the single transfer tool put the first stitch on to the same needle as the second. Return first needle to R.P.

For decreases of more than one stitch the procedure is first of all the same but only on the same side as the slide. Then push the second needle into U.W., lay the wool across the open needle latch and form a single stitch by hand-operating the needle. Repeat as required.

After completing decrease on one side, knit one row and repeat decrease on other side.

All empty needles must be returned to R.P.



III. 9

III. 10

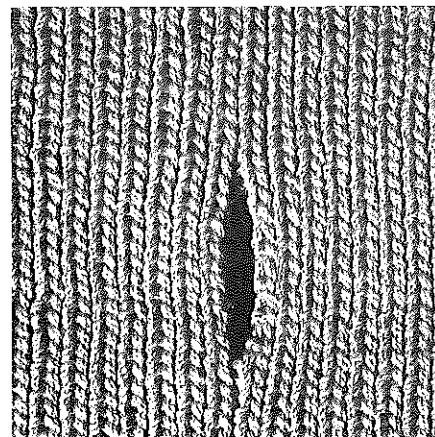

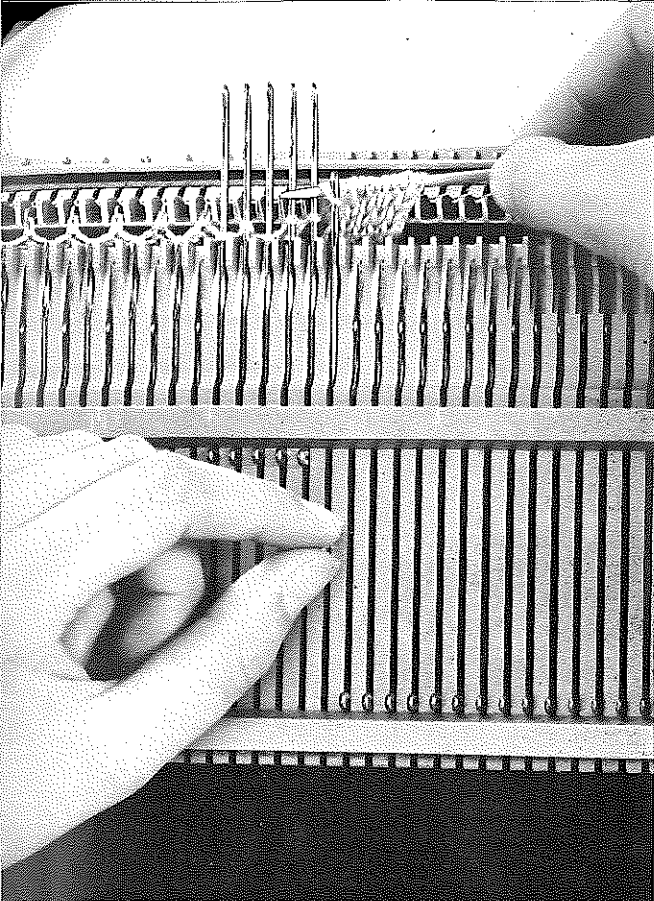

III. 11

**Decreases with circular knitting.**

With the double transfer tool lift off two stitches and transfer by one needle inwards. Return side weights. Repeat the same decrease on the other bed, as both sides must be identical.

**Increasing.**

On the slide-side, bring the required number of needles into W.P. and knit. Hang comb into the stitches. Use side weights from 2nd row.

**Holding stitches on Hand Knitting Needle.**

(Illustration 11)

Push needles into H.P. then bring back one by one. Take stitches up from behind, with the other hand pull back latch needle. Empty needles to R.P.

Stitches can be transferred (Illustration 12) from hand needle to machine needles either by single transfer tool or directly. Put needles in upper working position and knit. Use side weights.

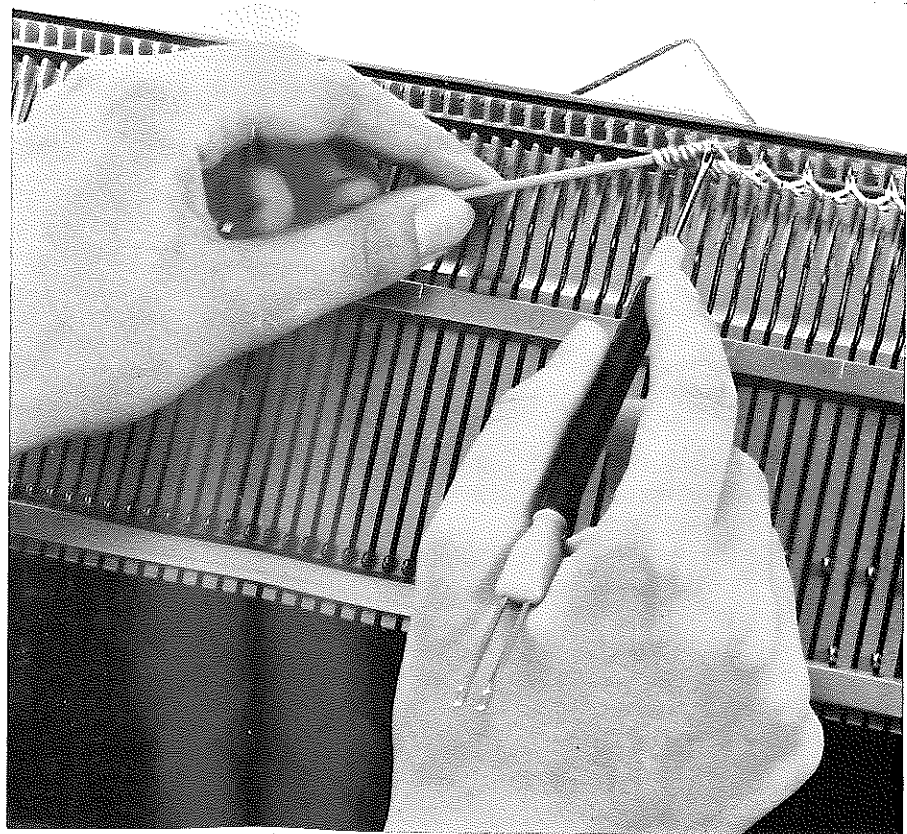

III. 12

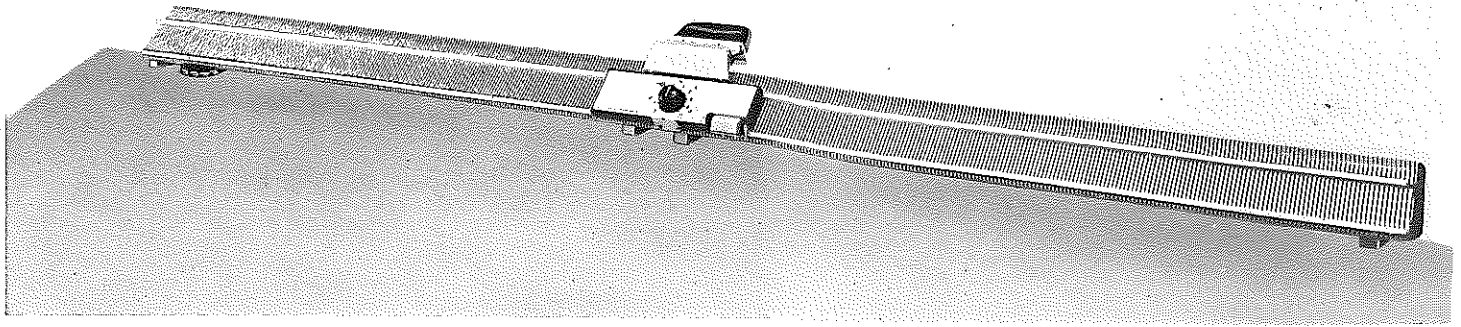

III. 13

## Single-bed knitting

### Double length operation. (Illustration 13)

For very wide pieces the two beds can be joined sideways without much difficulty.

Remove both slides and end pieces (11). Pull out both slide rail fasteners (8). Loosen L-shape screws and remove front bed. Remove the right hand carrying bolt which connects the two needle beds. The F.B. is then put side by side, against the right hand side of the rear bed, and fastened by the spare table clamp. Between the two beds a new needle channel is formed into which one of the spare needles is inserted. Also put spare needles into the two channels of the slide rail fasteners. The slide rails of the front bed are now pushed to the right about half an inch and the rails of the rear bed pushed right up to them from the left, so that the two rails touch. Return the rear slide to the rails. The machine is now ready to knit. When the carrying bolt is put back into position, ensure that the bush is properly fitted.

### I. Closed edge cast-on (with comb)

Slide on the right. Needles to U.W. all latches open. Hold cast-on comb underneath needles with your left hand. The wool is fastened to the left hand bolt, then round the needle hook, round the comb hook to the next needle (Illustration 14). The wool crosses underneath the needle. Check that latches are open. Thread machine. Set control on N and bring slide over needles. Knit two rows. Fit stocking stitch bar (43) and fasten. Always use side weights specially with thick wool.

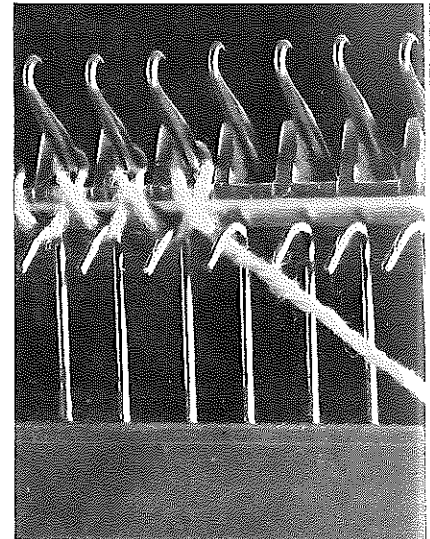

III. 14

### II. Closed edge cast-on (without comb)

As for above I, except that the wool is wound around the needles only. Insert the comb after the first row and the stocking bar after the third row.

### III. Open cast-on.

Hold comb between needles and knit over 1 row. Fasten stocking stitch bar.

### IV. Automatic cast-on.

Cast on as for K 1 P 1. Knit circular rows. Transfer all stitches to R.B., remove F.B. fit stocking stitch bar, loosen stitch size and continue knitting.

### The hem.

After casting on knit a piece twice the size of the hem. Bring comb back to the top with the single transfer tool put the stitches back on the needles. This produces a very satisfactory closed hem.

### Mock-rib.

By missing every other needle, an effect is produced which resembles ribbing. This can be used as a hem or border.

### Increasing.

You can only increase on the slide side. For single increases just bring outside needle from R.P. to U.W.

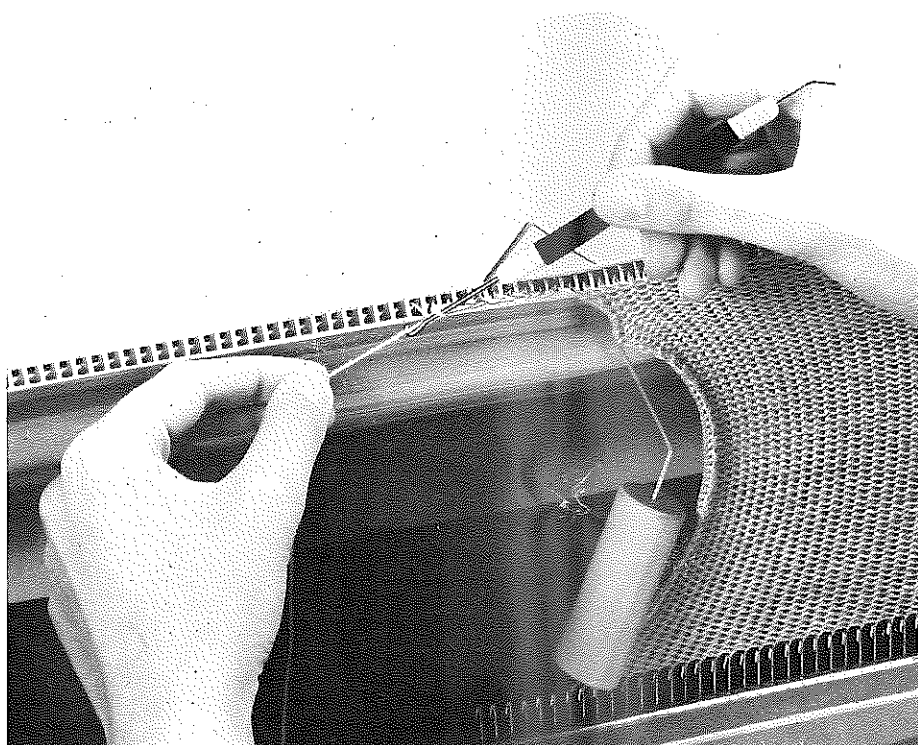

III. 15

**Larger increases.** (Illustration 15)

Form crochet chain outwards over the required number of needles, or wind on as under II. Knit over this in the normal way.

Increasing in the centre transfer stitches by one needle to the outside with your Multi-Transfer tool. Take a stitch from the right or left on the row below and put it on the empty needle.

**Decreasing in the centre.**

Take stitch off and transfer to next needle. Transfer other stitches with Mult-Transfer tool.

**Decreasing on the outside.**

Same as with double bed operation. (Page 11.)

III. 16

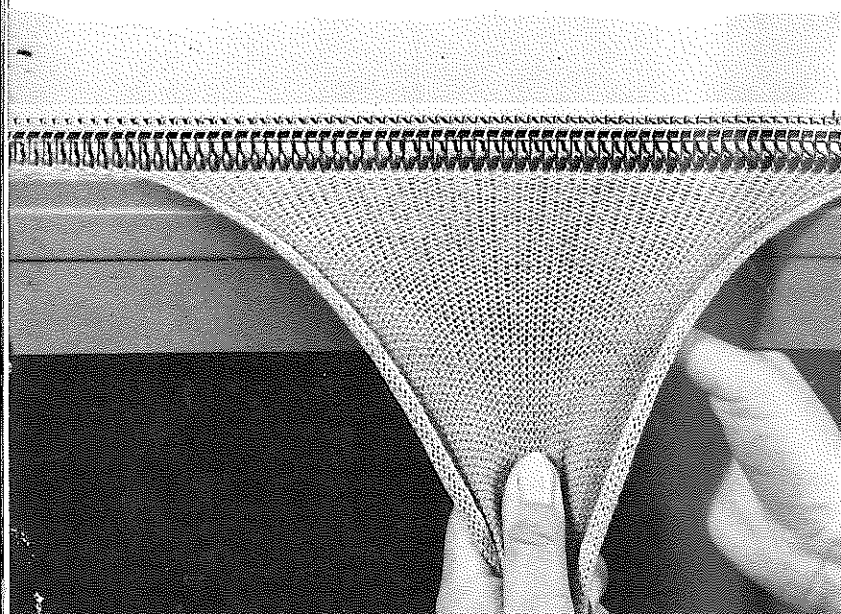

**Re-hanging comb.** (Illustration 16)

With single bed knitting the comb must be re-hung more frequently. For this purpose the needles are pushed into the H.P. The comb is re-hung on the top row, the latches are opened, and the needles are returned to U.W. Remove stocking stitch bar, knit two rows, replace it and continue knitting.

**All other operations** are the same as with double bed knitting.

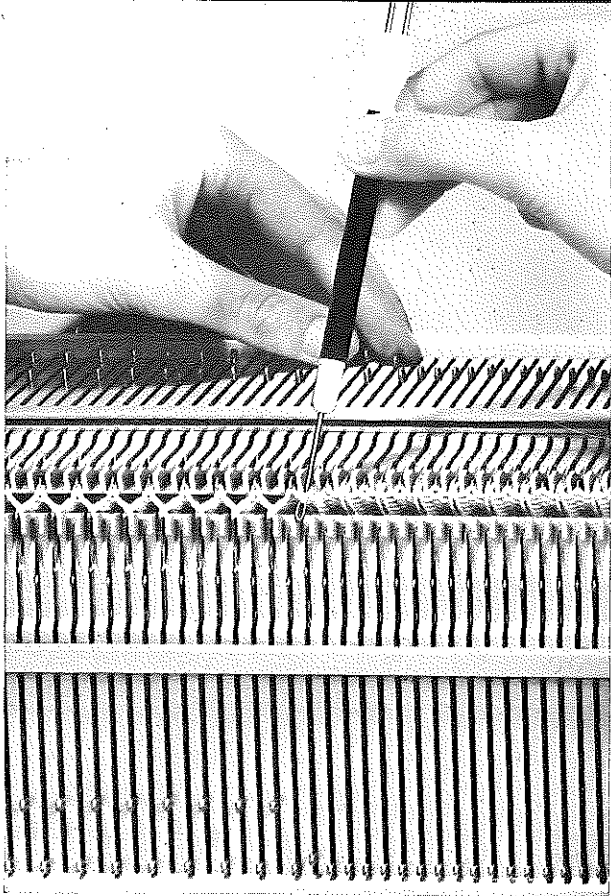

III. 17

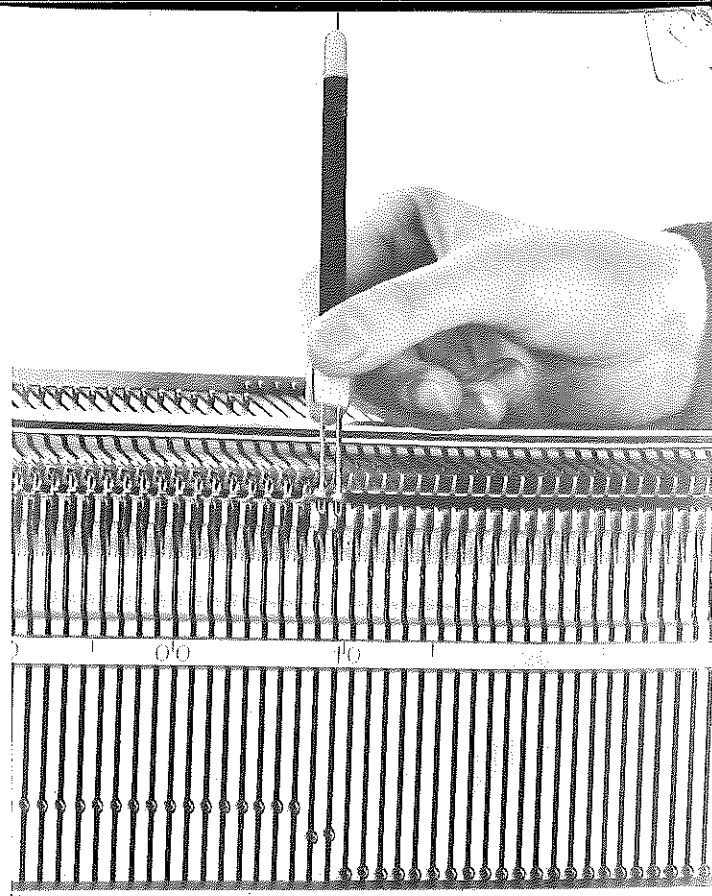

III. 18

### Colour patterns.

Basic colours threaded. Bring pattern needles into U.W. with open latches. Insert contrasting thread, push needles back until latches close and stitches form. Knit over with slide in the normal way.

### Socks, stockings, toes and heels.

Racking wheel on  $\frac{1}{2}$ . Tension 4 on both needlebeds. Stitch type controls on N.

Set up 64 stitches in K1 P1 every other needle. Cast on and knit 60 rows for welt, ending with slide on right. Pull undone 16 stitches (see page 9). Transfer F.B. stitches to empty needles on R.B.

With multi-transfer tool transfer 16 stitches from each end on to F.B. so that they face the centre 32 stitches on R.B. To do this the multi-transfer tool must be turned around which is quite easy with the beds parted slightly. Set both beds to tension 7 and stitch type black R. Knit length required for leg.

III. 19

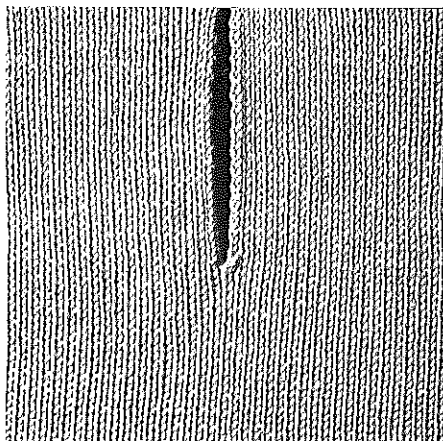

III. 20

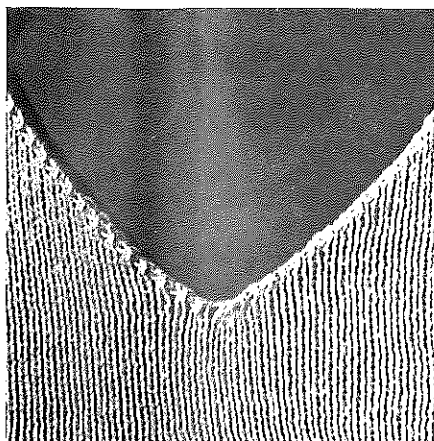

III. 21

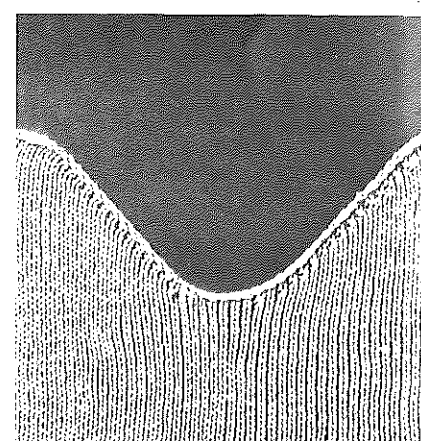



Transfer 16 stitches from each end of F.B. on to a multi-transfer tool. Remove F.B. This leaves 32 stitches in W.P. on R.B.

Change stitch type control to N. Fit stocking stitch bar. Put the needle nearest to slide in to H.P. and repeat 20 times. Use side weights or pull down by hand to prevent the bulge of the work lifting stitches off the needles.

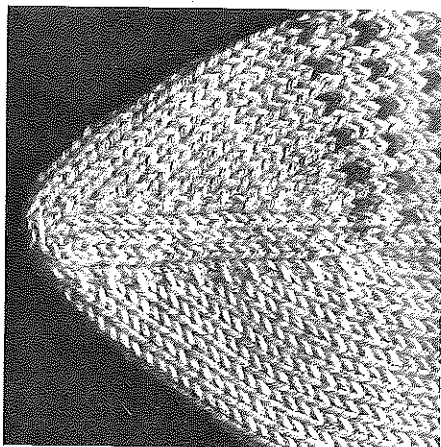

III. 22

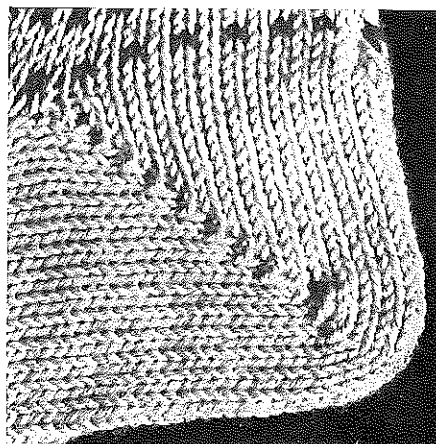

III. 23

On the side away from the slide return the inner H.P. needle to U.W. with open latch. Repeat 20 times. Set R.B. stitch type to black R. Remove stocking stitch bar. Replace F.B. and replace stitches from multi-transfer tool on F.B. needles.

Continue knitting circular for length of foot required, 60 rows.

**The toe:** Working on both beds and on both sides of needle bed decrease one stitch by transferring second stitch on to the third and first stitch on to the second. Put empty needle in R.P. knit two circular rows and repeat this whole procedure six times. Continue decreasing in this way, but knit one row in between. Repeat until eight stitches remain. Cast off.

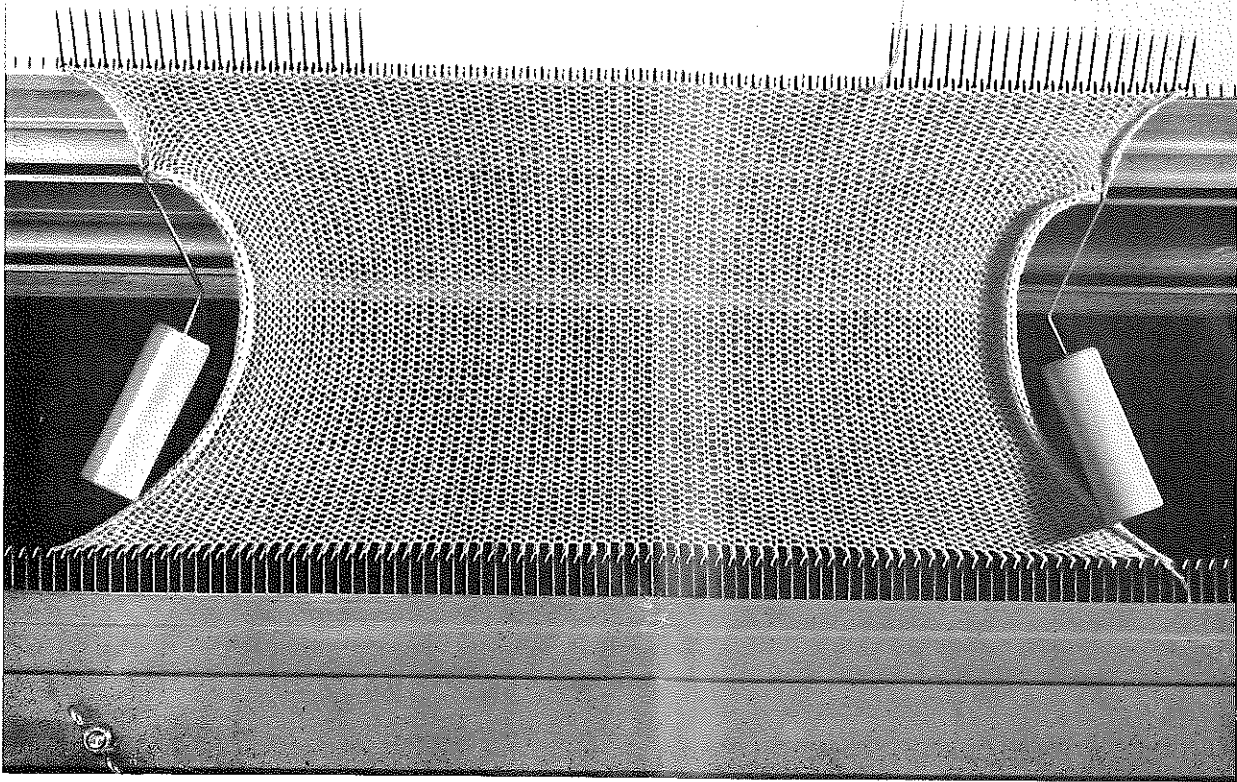

III. 24

### Changing needles

Remove both end pieces and slide rail fasteners. The rails can now be pushed to the right. Needles can be removed and replaced. (Illustration 25 and 26.)

In order to remove a jammed slide (caused only by mis-use) from the needle bed, it is sufficient to remove the upper rail. Replace rail from right (never from the left) and secure end pieces.

A needle with a bent latch is best changed.

III. 26

See last page for abbreviations

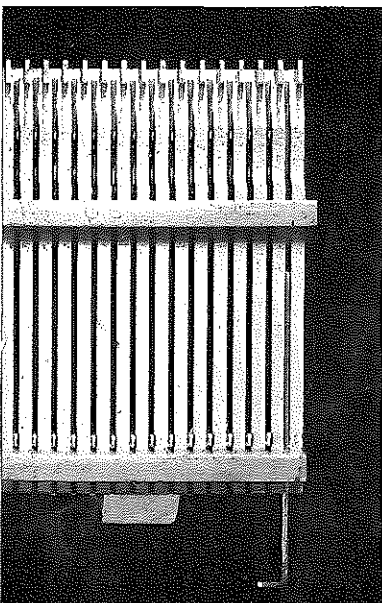

III. 25

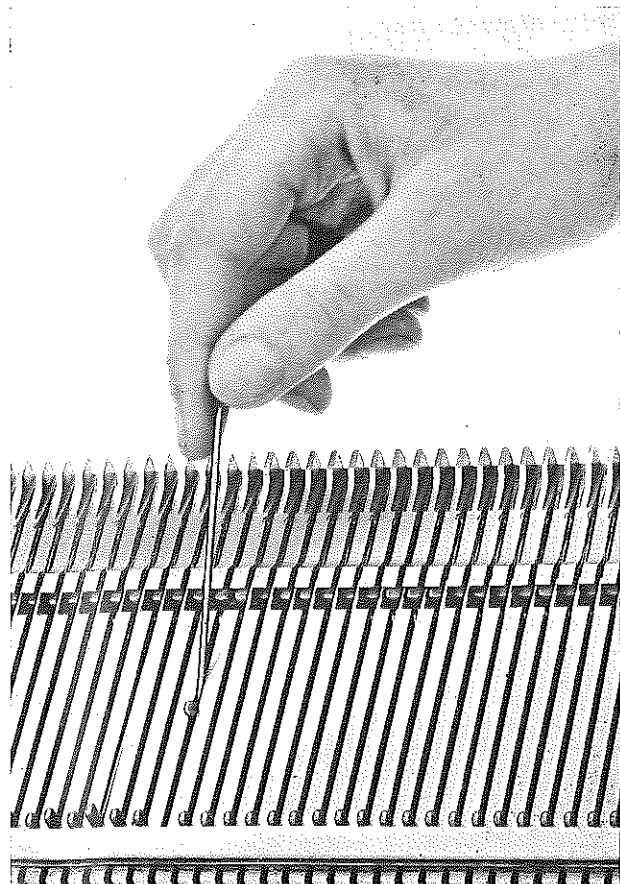

## Maintenance

The life of the machine depends on good maintenance.

Incorrect functioning is usually the result of neglect. Always cover the machine when it is not in use. Before using it again, remove all particles of wool and dust from the needle grooves and the slide channels with a soft brush and, when necessary, very lightly oil.

Oil sparingly, but regularly, with finest sewing machine oil (not salad oil or glycerine). The parts which should be oiled are shown in illustration 27. After applying oil wipe clean with a soft cloth to remove all surplus oil.

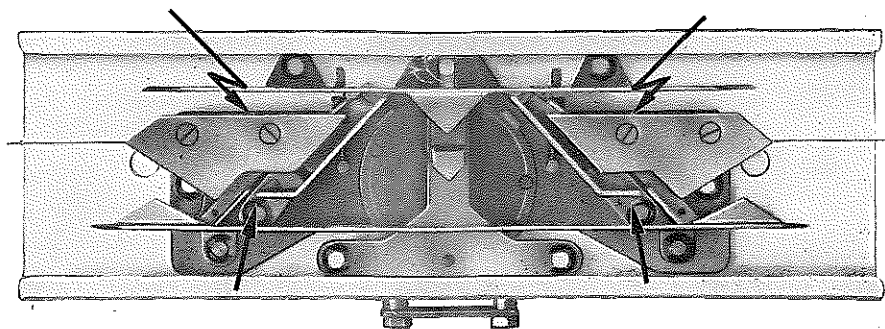

Ill. 27

## Fault finding

### **Slide movement heavy.**

Wool tension too tight, loosen the tension screw a little and ensure that the tension wire bends sufficiently.

Stitch size too small or too large. The wrong setting on the stitch size dial for the thickness of wool being used. The needles require lubrication.

### **Slide jammed.**

Never force slide. Turn both controls to 0 and unthread. If slide still cannot be moved, turn controls one complete turn and back to 0. If this does not show the desired result, remove slide rail, as described on page 17. Turn stitch type control again completely before knitting.

### **Jamming is caused by:**

Incorrect line-up of needles. (See illustration 1.)

Careless handling or forcing of racking wheel.

Control knobs not properly engaged in position.

Needle latch bent (page 17).

### **End stitches may drop if:**

The slide has been moved too far away from the end needle, and the first stitch of the next row has therefore too little tension. You can restore adequate tension by pulling the wool by hand.

The wool brake is not adjusted tight enough;  
The weighted comb does not pull evenly and weights only one side.

The comb is not re-hung in time;  
The sideweights are not used or re-hung.

The bristles of the brushes are broken or bent (cut if necessary);  
The comb rests on the table top.

The stitch size is incorrect for the type of wool used.

#### Other stitches may drop if.

Needle latches are bent or broken (see needle changing on page 17).

#### Irregular texture can be caused

when the stitch control is not properly engaged in its chosen position,  
by incorrect use of racking wheel,  
by wrong positioning of racking wheel when not in use,  
when with knitting Half Patent the stitch size on the N slide is not set a number higher than on the P side.

The stitch size should never be increased by more than two sizes at a time during the knitting. e. g. it must not be set from 4 to 8 at once.

## Knitting patterns

Abbreviations following the pattern numbers indicate the stitch technique.

N = Normal pattern	NR = Normal with racking
P = Patent (Fisherman's rib)	PR = Patent with racking
H = Half patent (single Fisherman's rib)	HR = Half patent with racking
	PW = Weaving with patent
W = Weaving patterns	WH = Weaving with half patent
	TP = Transferring with patent
T = Transfer patterns	TH = Transferring with half patent

In order to recognise the operation clearly, remember the following marks and abbreviations are used:

R.	= Racking
--	= Knit 1 row
=	= Knit 2 rows
≡	= Knit 3 rows
≡≡	= Knit 4 rows

For a racking pattern the instructions might be:

No. 34 HR For cast on Racking wheel on 2, after  
cast on Racking wheel on 1 for welt.

RB	P5	11.11.11	} Positions of needles when casting on
FB	N6	11.11.11	

Slide on left.

R = 2 — 1 — 2 and so on.

See last page for abbreviations

This pattern is K 2 P 2 in half patent with racking. First the racking wheel is turned to 2, then the needles are selected as described. With both controls on N the cast-on row is formed. As soon as the comb is hung, the racking wheel must be turned to 1 and remains there while the welt is knitted. The last row of the welt ends with the slide on the left hand side. Now turn rear bed control knob to P and stitch size to 5, on the front bed turn to N and 6 respectively. The racking starts by turning the wheel on 2, knit one row, turn Racking wheel to 1, knit one row, turn to 2 and so on.

Unless otherwise stated, the slide should be on the right hand side before commencing a pattern. If the correct racking sequence is not observed, the result cannot be according to pattern.

### **Weaving patterns**

This pattern is produced by laying across the needles and including in the pattern a thread which is not actually knitted. The result resembles a weaved fabric of great firmness but little elasticity. It should therefore not be used where elasticity is required, e. g. for pullovers.

Any type of wool can be used for the weaving rows, as long as it is slightly thicker than the basic material. For decorative effects thicker wools such as carpet wool, home spun wool can be used and carpeting can be produced if the basic knitting texture is strong and tight. It is best to use a good 2 ply machine yarn for this.

Weaving is quite simple and does not take much time. When a row of knitting is completed, lay your weaving thread across **between** the needle heads and run slide over. The thread is now closed in by 2 rows of knitting. An elastic band can be included in the same way to produce an elastic edge. It can be adjusted according to the degree of elasticity required.

### **Patent. (Fisherman's rib)**

A patent texture produced from thin wool with every other needle will stretch vertically when washed, a thick wool patent pattern will give sideways. To avoid disappointment, it is best to adhere to using every needle for patent with thin wools, every other needle thick wools.

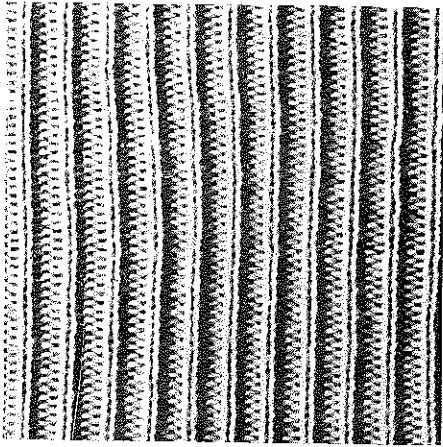

28 N

RB      $\frac{N}{N}$      IIII  
FB      $\frac{N}{N}$      IIII  
RW on 1

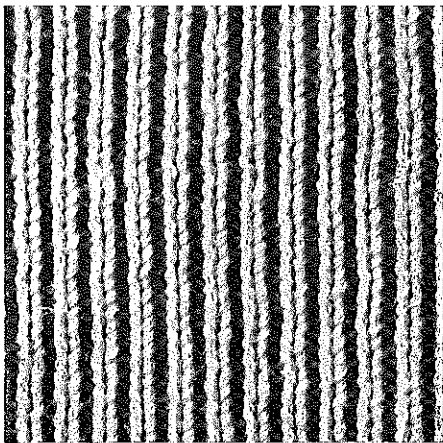

29 N

RB      $\frac{N}{N}$      I.I.I.I  
FB      $\frac{N}{N}$      I.I.I.I  
RW on 1/2

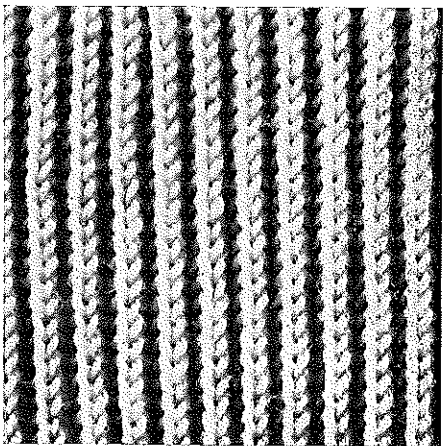

30 P

RB      $\frac{P}{P}$      IIII  
FB      $\frac{P}{P}$      IIII  
RW on 1

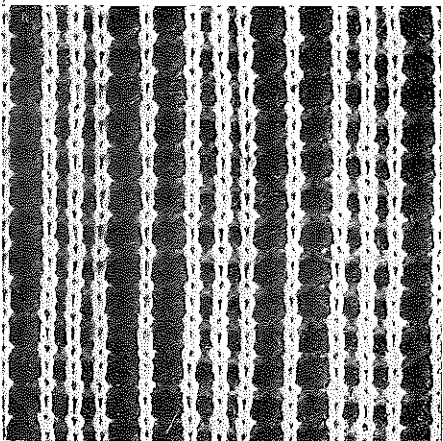

31 W

RB      $\frac{N}{N}$      I.I.II.II.II.II.  
FB      $\frac{N}{N}$      I.I.I.I.I.I.I.I.  
RW on 1/2

Lay across second colour after each 2nd row.

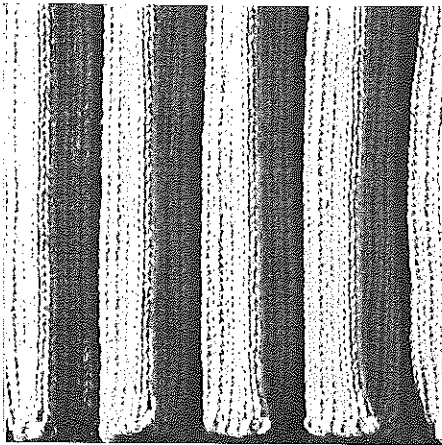

32 N

**Pleats.** Ribbing with all needles. Best use thin 2 ply wool. The distance between the two empty needle groups can be adjusted to determine the distance between the pleats.

RW on 1.

RB	$\frac{N}{N}$	..     .....
FB	$\frac{N}{N}$	.....     .....

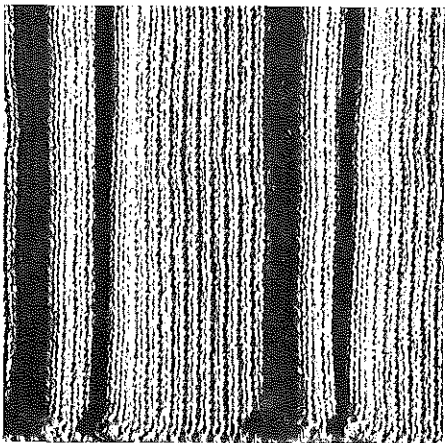

33 N

**Folds.** Same as 32 N. Grouping can be changed as required.

RW on 1.

(52 needle pattern.)

RB	$\frac{N}{N}$	..     .....
FB	$\frac{N}{N}$	..     .....     .....

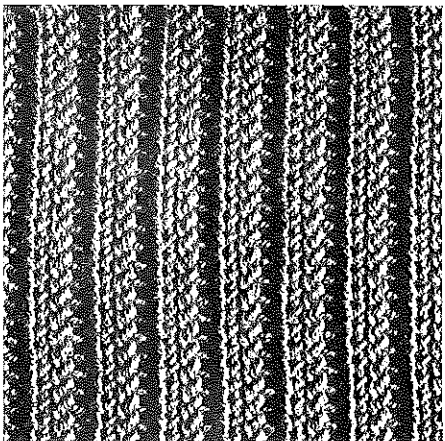

34 HR

For cast on RW on 2, then on 1 for welt.

RB	$\frac{P5}{N6}$	..  ..
FB	$\frac{N6}{N6}$	..  ..  .

Slide on left.

R.: 2 - 1 - 2 - 1 - 2 - 1 - etc.

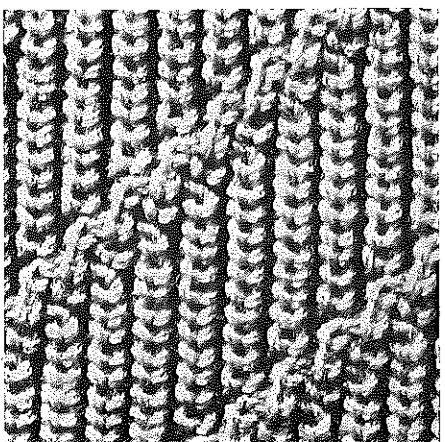

35 TH

RW on 1 (16 needle pattern).

RB	$\frac{P7}{N8}$	.....
FB	$\frac{N8}{N8}$	.....

\*\*\*                  \*\*\*

On front bed

6th and 8th stitch to 7th needle

14th and 16th stitch to 15th needle and so on.

Knit 4 rows.

Move pattern over to next needle on right.

Knit 4 rows, and so on.

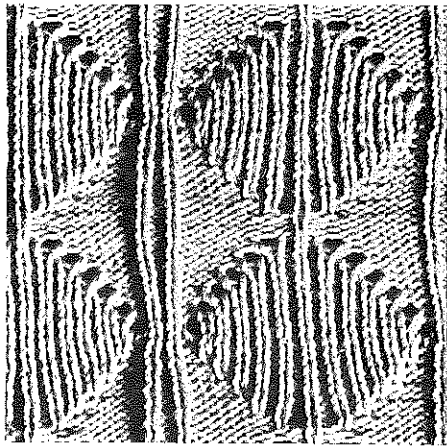

35 T

RW on 1 (30 needle pattern).

		<b>a b c d e f g g f e d c b a</b>
RB	<u>N</u>	
FB	<u>N</u>	
		1 2 3 4 5 6 7 6 5 4 3 2 1

<ul style="list-style-type: none"> <li>* Transfer both stitches 1 on a</li> <li>Transfer both stitches 2 on b</li> <li>Transfer both stitches 3 on c</li> <li>Transfer both stitches 4 on d</li> <li>Transfer both stitches 5 on e</li> <li>Transfer both stitches 6 on f</li> <li>Transfer both stitches f on 6</li> <li>Transfer both stitches e on 5</li> <li>Transfer both stitches d on 4</li> <li>Transfer both stitches c on 3</li> <li>Transfer both stitches b on 2</li> <li>Transfer both stitches a on 1</li> </ul>	}	Empty needles in RP
		Repeat from *

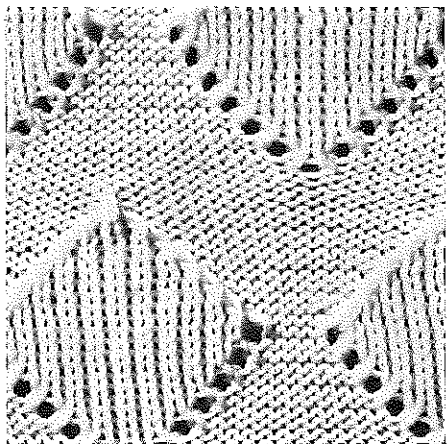

36 T

RW on 1 (42 needle pattern).

RB	<u>N</u>	
FB	<u>N</u>	
		1 2 3 4 5 6 7 6 5 4 3 2 1

<ul style="list-style-type: none"> <li>* Needle 7 WP</li> <li>Both needles 6 WP</li> <li>Both needles 5 WP</li> <li>Both needles 4 WP</li> <li>Both needles 3 WP</li> <li>Both needles 2 WP</li> <li>Both needles 1 WP</li> <li>Transfer both stitches 1 on 2</li> <li>Transfer both stitches 2 on 3</li> <li>Transfer both stitches 3 on 4</li> <li>Transfer both stitches 4 on 5</li> <li>Transfer both stitches 5 on 6</li> <li>Transfer both stitches 6 on 7</li> </ul>	}	Empty needles in RP
		Repeat from *, racking as per pattern.

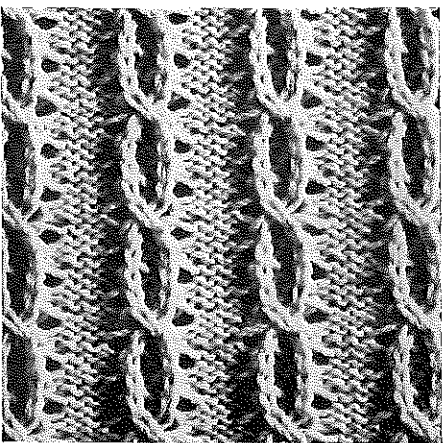

37 T

RW on 1 (12 needle pattern).

RB	<u>N</u>	
FB	<u>N</u>	. . .   . . .   . . .

Cross the 2 stitches on front bed after each 10th row.

See last page for abbreviations



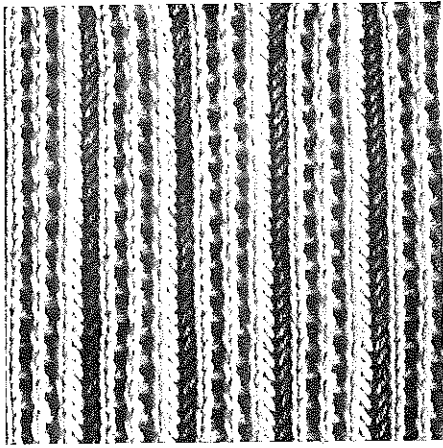

39 PR

For cast-on and welt (with every 2nd needle) RW on 1/2  
 Thereafter RW on 1, transfer stitches as follows:

RB	$\frac{P}{}$	1.1.1.1.1.1.1.1.1.1
FB	$\frac{P}{}$	1.1.1.1.1.1.1.1.1.1

Slide on left.

R.: = 2 = 1 = 2 = 1 and so on.

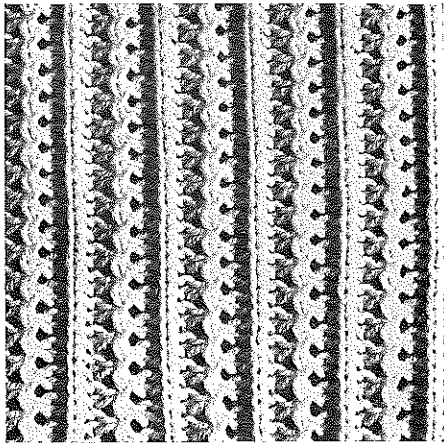

40 PR

Rearside of above pattern.

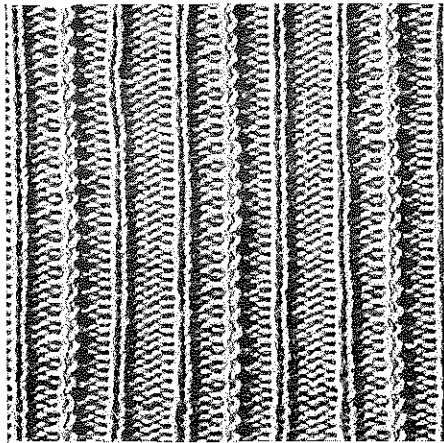

41 R

For cast-on and welt (with all needles) RW on 2:  
 Thereafter transfer stitches as follows:

RB	$\frac{N}{}$	111.11.111.11.111.1
FB	$\frac{N}{}$	1.1.1.1.1.1.1.1.1.1

R.: 1 - 2 - 1 - 2 - and so on.

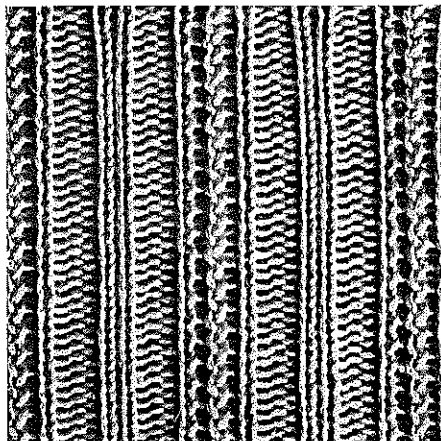

42 R

Rearside of above pattern.

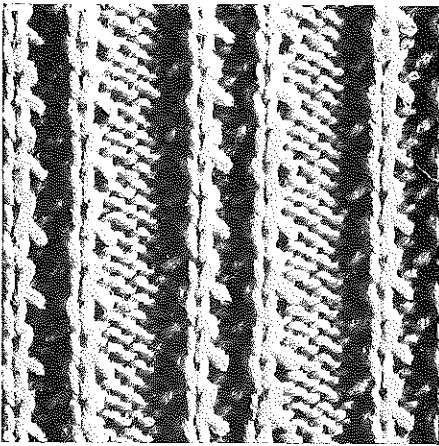

43 HR

For cast-on and welt (with all needles) RW on 1.  
Thereafter transfer stitches as follows:

RB	$\frac{N8}{P7}$	
FB		1...1...1...1...1...1...1

R.: = 2 = 1 = 2 = 1 and so on.

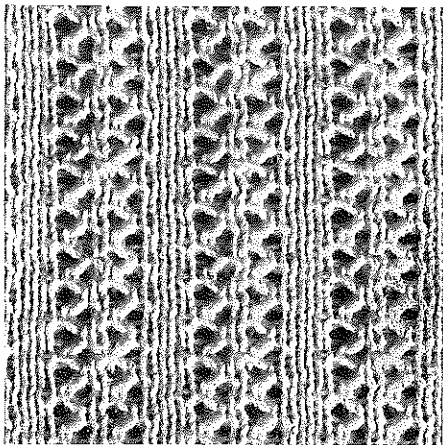

44 HR

Rearside of above pattern.

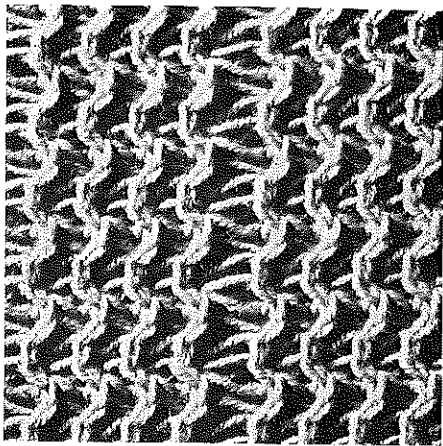

45 PR

For cast-on and welt (with every 2nd needle) RW on  $\frac{1}{2}$ .  
Thereafter RW on 1, transfer stitches as follows:

RB	$\frac{P}{P}$	1.1.1.1...1.1.1.1
FB		1.1.1.1...1.1.1.1

R.  $\equiv 2 \equiv 1 \equiv 2 \equiv 1$  and so on.

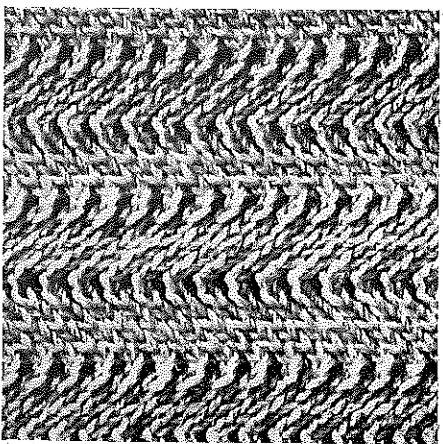

46 NR

For cast-on and welt (with all needles) RW on 1.

RB	$\frac{N}{N}$	
FB		

R. \* - 2 - 3 - 4 - 5 - 6 - 7 - 6 - 5 - 4 - 3 - 2 - 1; repeat from \*.

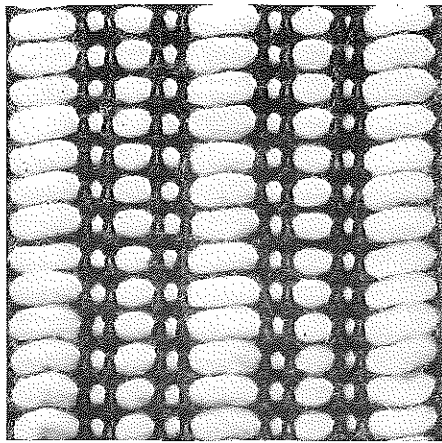

47 WH

RW on  $\frac{1}{2}$ .

RB  $\frac{N8}{N}$  | | | | . . . | | | | . . . | | | | . . . | | | | . . . |

FB  $\frac{P7}{N}$  | . . . | . . . | . . . | . . . | . . . | . . . | . . . | . . . | . . . | . . . |

Lay across second colour after each 2nd row.

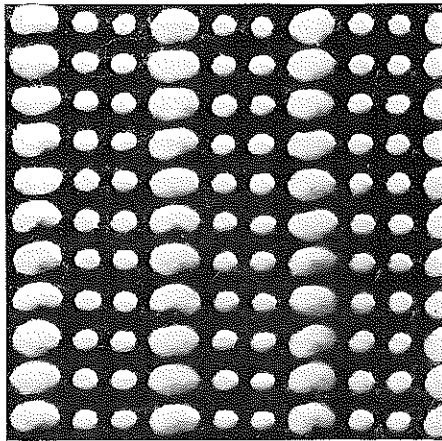

48 W

RW on  $\frac{1}{2}$ .

RB  $\frac{N}{N}$  | | | | . . . | | | | . . . | | | | . . . | | | | . . . |

FB  $\frac{N}{N}$  | . . . | . . . | . . . | . . . | . . . | . . . | . . . | . . . | . . . |

Lay across second colour after each fourth row.

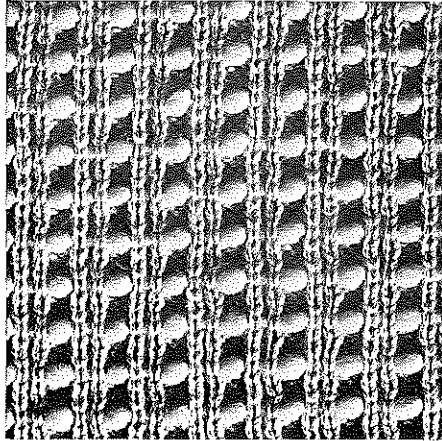

49 W

RW on  $\frac{1}{2}$ .

RB  $\frac{N}{N}$  | | | | . . . | | | | . . . | | | | . . . | | | | . . . |

FB  $\frac{N}{N}$  | . . . | . . . | . . . | . . . | . . . | . . . | . . . | . . . | . . . |

Lay across second colour after each fourth row.

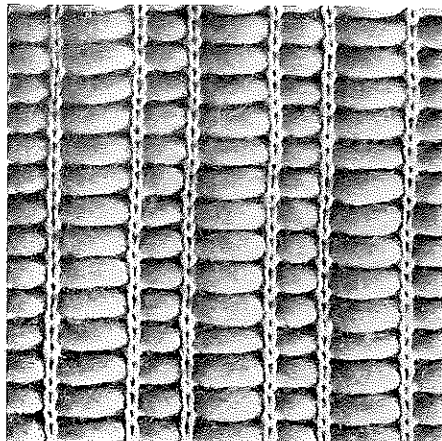

50 W

RW on  $\frac{1}{2}$ .

RB  $\frac{N}{N}$  | | | | . . . | | | | . . . | | | | . . . | | | | . . . |

FB  $\frac{N}{N}$  | . . . | . . . | . . . | . . . | . . . | . . . | . . . | . . . | . . . |

Lay across second colour after each 2nd row.

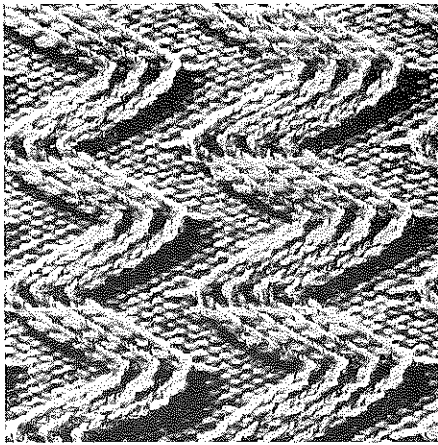

51 HR

For cast-on and welt (with all needles) RW on 1.  
Thereafter transfer stitches as follows:

RB	$\frac{N7}{P6}$	
FB		.....

R.: \* - 2 - 3 - 4 - 5 - 6 - 7 - 6 - 5 - 4 - 3 - 2 - 1; repeat from \*.

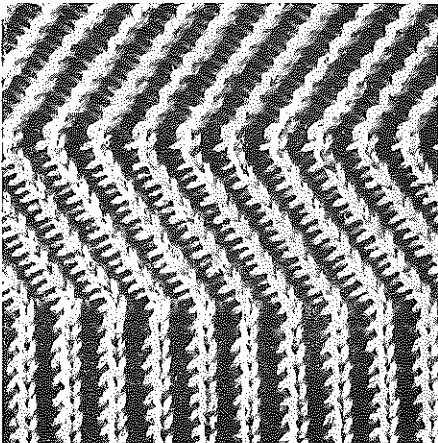

52 PR

For cast-on and welt (with every 2nd needle) RW on 1/2.  
Thereafter RW on 1.

RB	$\frac{P}{P}$	1.1.1.1
FB		1.1.1.1

R.: \* - 2 - 1 - 2 - 1 and so on, 20th row no racking.

Repeat from \*.

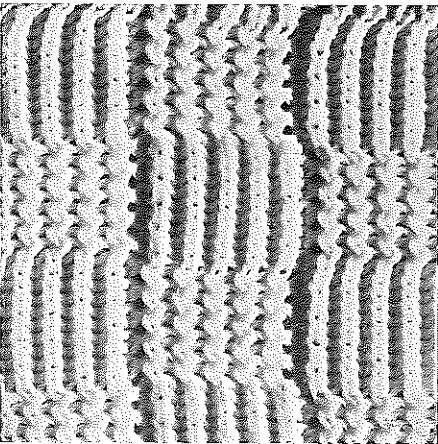

53 PR

For cast-on and welt (with every 2nd needle) RW on 1/2.  
Thereafter RW on 2, transfer stitches as follows:

RB	$\frac{P}{P}$	1.1.1.1.1.1.1.1.1.1
FB		1.1.1.1.1.1.1.1.1.1

Slide on left.

R.: \* = 1 = 2 = 1 = 2 = 1 = 2 = 1 = 2 = 1 = 2 = 3 = 2  
= 3 = 2 = 3 = 2 = 3 = 2 = 3 = 2 repeat from \*.

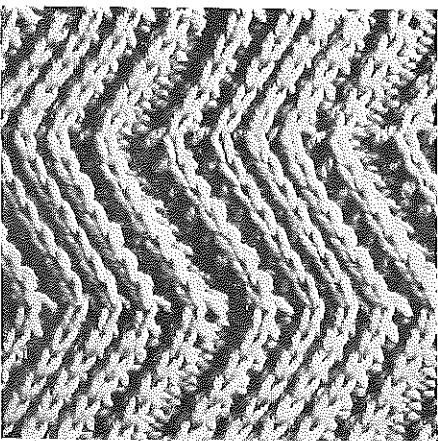

54 HR

For cast-on and welt (with all needles) RW on 1.  
Thereafter transfer stitches as follows:

RB	$\frac{N7}{P6}$	
FB		1.1.1.1.1.1.1.1.1.1

R.: \* = 2 = 3 = 4 = 5 = 6 = 7 = 6 = 5 = 4 = 3 = 2 = 1

Repeat from \*.

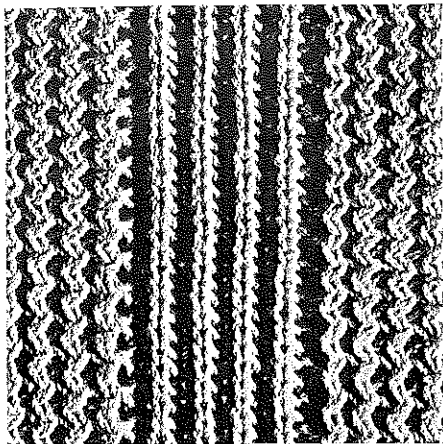

55 PR

For cast-on and welt (with every 2nd needle) RW on 1/2.  
Thereafter RW on 1; transfer stitches as follows:

RB	$\frac{P}{1}$	1.1.1.1.1.1.1.1.1.1
FB	$\frac{P}{1}$	1.1.1.1.1.1.1.1.1.1

Slide on left.

R.: = 2 = 1 = 2 = 1 and so on.

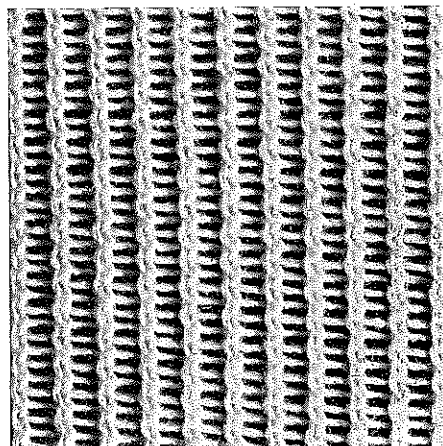

56 NR

For cast-on and welt (with every 2nd needle) RW on 1/2.  
Thereafter RW on 1.

RB	$\frac{N}{1}$	1.1.1.1
FB	$\frac{N}{1}$	1.1.1.1

R.: - 2 - 1 - 2 - 1 and so on.

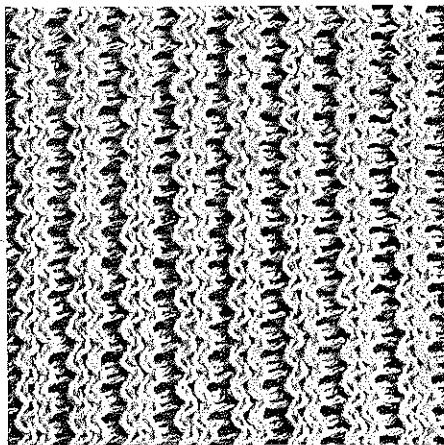

57 HR

For cast-on and welt (with every 2nd needle) RW on 1/2.  
Thereafter RW on 1; transfer stitches as follows:

RB	$\frac{P5}{1}$	11.11.11
FB	$\frac{N6}{1}$	11.11.11

Slide on left.

R.: = 2 = 1 = 2 = 1 and so on.

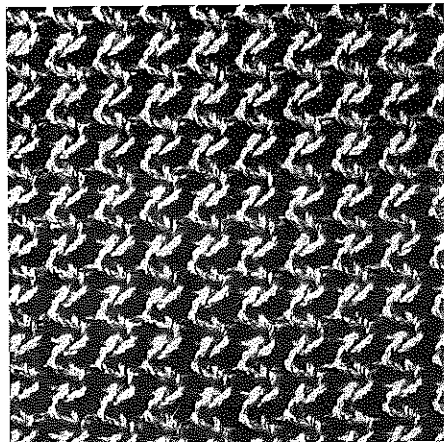

58 HR

For cast-on and welt (with every 2nd needle) RW on 1/2.  
Thereafter RW on 1.

RB	$\frac{P7}{1}$	1.1.1.1
FB	$\frac{N8}{1}$	1.1.1.1

Slide on left.

R.: = 2 = 1 = 2 = 1 and so on.

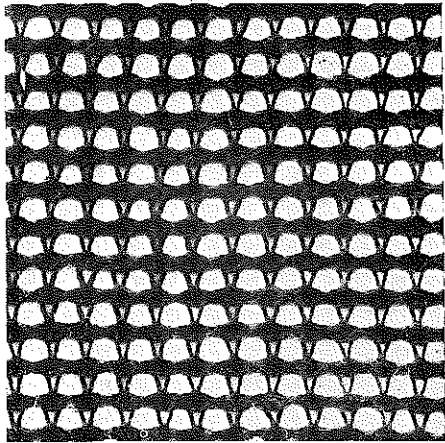

59 WH

RW on  $\frac{1}{2}$ .

RB	$\frac{N}{N}$	11.11.11.1
FB	$\frac{N}{N}$	1.1.1.1.1

Lay across second colour after each 4th row.

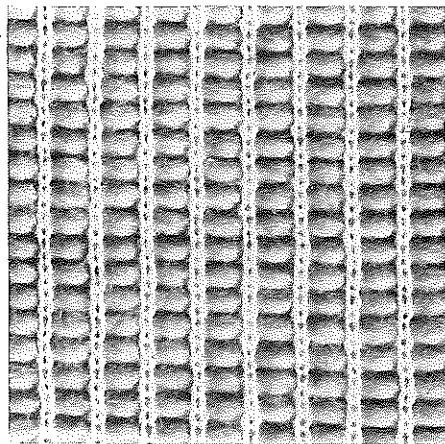

60 W

RW on  $\frac{1}{2}$ .

RB	$\frac{N}{N}$	11.11.11.1
FB	$\frac{N}{N}$	1.1.1.1.1

Lay across second colour after each 2nd row.

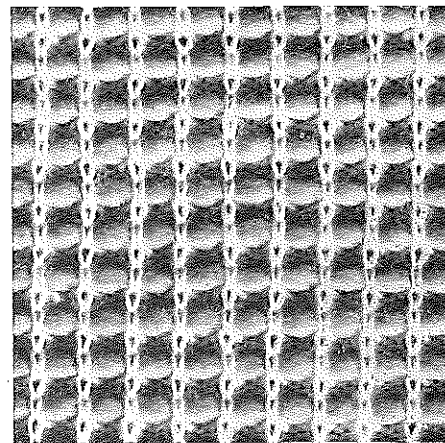

61 W

RW on  $\frac{1}{2}$ .

RB	$\frac{N}{N}$	1.1.1.1
FB	$\frac{N}{N}$	1.1.1.1

Lay across second colour after each 4th row.

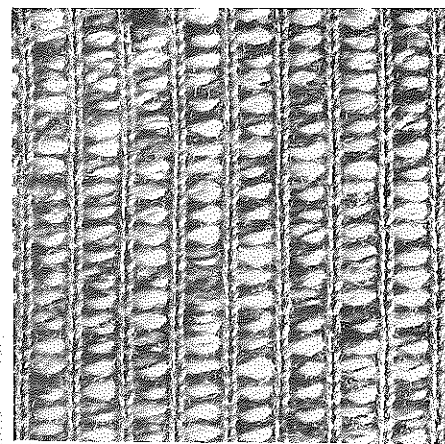

62 W

As above.

Lay across second colour after each 2nd row.

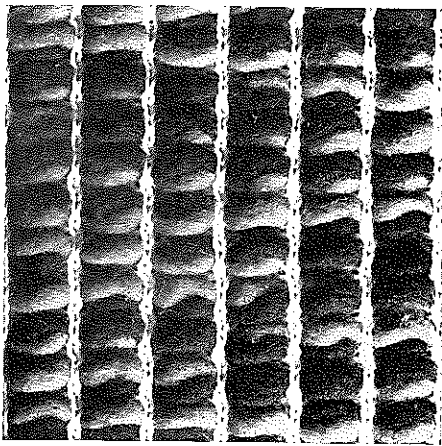

63 W

RW on  $\frac{1}{2}$ .

RB	$\frac{N}{N}$	1111.1111.1
FB	$\frac{N}{N}$	1....1....1

Lay across second colours, red and black together, after each fourth row.

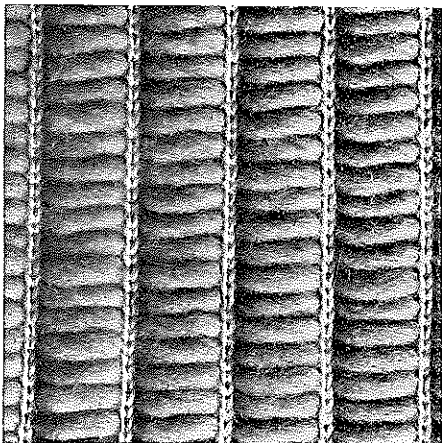

64 W

Needles as above.

Lay across second colour after each 2nd colour.

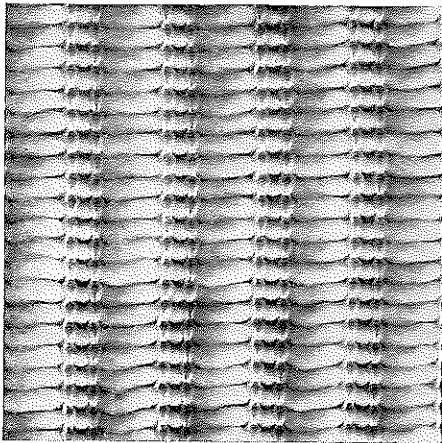

65 WH

RW ON  $\frac{1}{2}$ .

RB	$\frac{P7}{N8}$	1.1...1.1...1.1
FB	$\frac{N8}{N8}$	1.1...1.1...1.1

Lay across second colour after each 2nd row.

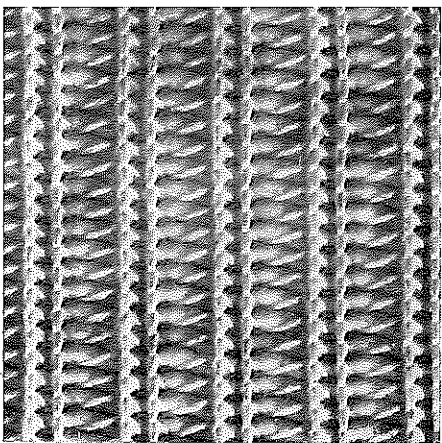

66 W

Rearside of above pattern.

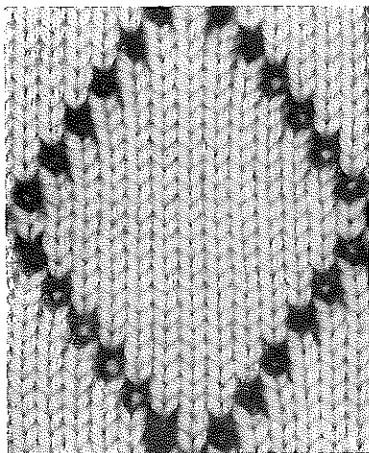

67

RB N | | | | | | | | | | | | | |

White in wool feed.

1st row: Feed every 13th needle red by hand and knit over.

2nd row: Feed 12th and 14th needle by hand and continue as per pattern.

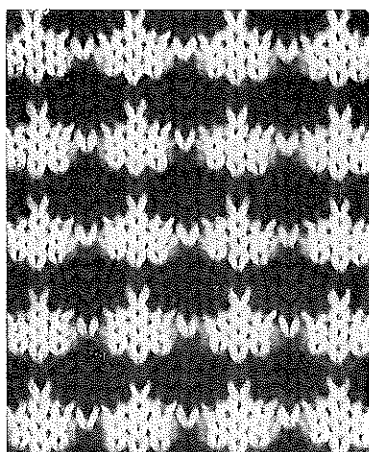

68

RB N | | | | | | | | | | | | | | | |  
a b a b a b a b

White 4 rows.

Push needles a into H.P.

\* Red 3 rows, push H.P. needles to U.W.

Red 1 row.

Push needles b into H.P.

White three rows.

H.P. needles to U.W.

White 1 row and repeat from \*.

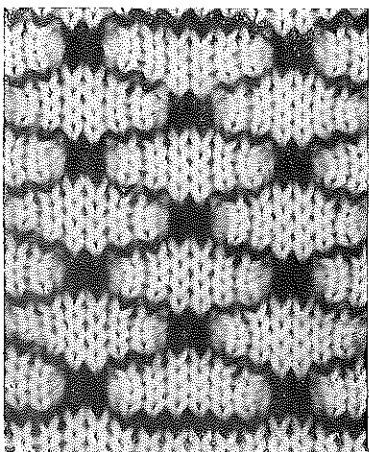

69

RB N | | | | | | | | | | | | | | | |  
b b a a b b a a

\* Red 1 row.

Push needles a into H.P.

White 4 rows, push H.P. needles to U.W.

Red 1 row. Control knob on 0. Move slide to other side.

Control knob on N. Needles b to H.P.

White 4 rows. Control knob on 0.

Move slide to other side.

Control knob on N. Repeat from \*.

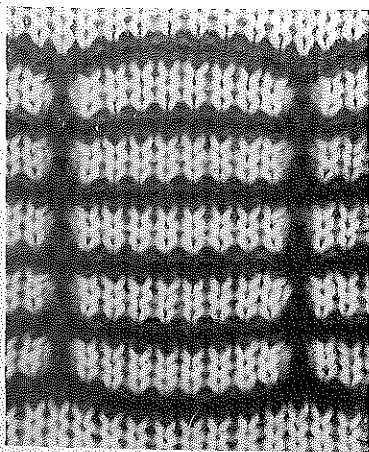

70

RB N | | | | | | | | | | | | | | | |

Red 2 rows.

Each 8th needle in H.P.

\* White 3 rows.

Control knob on 0. Move slide to other side.

Control knob on N.

H.P. Needles in U.W.

Red 2 rows.

Control knob on 0. Move slide to other side.

Control knob on N. Repeat from \*.

See last page for abbreviations



## List of contents

	Page		Page
<b>A</b>			
Assembling machine . . . . .	1		
<b>B</b>			
Bent latches . . . . .	17, 18, 19		
Bristles, damaged . . . . .	19		
Brushes . . . . .	19		
Button holes . . . . .	10—11		
<b>C</b>			
Carrying bolts . . . . .	13		
Cast on, closed-edge . . . . .	13		
Caston-on-comb . . . . .	7		
Cast on double bed . . . . .	8		
Cast on row . . . . .	5		
Cast on single bed . . . . .	13		
Changing needles . . . . .	17		
Circular knitting . . . . .	9		
Cleaning the machine . . . . .	18		
Clearing jammed slide . . . . .	18		
Closed cast on . . . . .	13		
Colour patterns . . . . .	15		
Comb (cast on) . . . . .	7		
Cone . . . . .	6		
Crochet chain . . . . .	14		
<b>D</b>			
Damaged bristles . . . . .	19		
<b>E</b>			
Edges . . . . .	13		
Elastic band . . . . .	20		
Eliminating faults . . . . .	18—19		
End stitch . . . . .	19		
<b>F</b>			
Faults, finding, eliminating . . . . .	19—19		
F.B. Front needle bed . . . . .	8		
Finding faults . . . . .	18—19		
Finishing edges . . . . .	10		
Fisherman's Rib . . . . .	9		
<b>H</b>			
Half Fisherman's Rib . . . . .	9		
Half patent . . . . .	9		
Half patent patterns . . . . .	9		
Hand cast on . . . . .	13		
Heel . . . . .	16		
Horizontal holes . . . . .	11		
Hose . . . . .	9		
H.P. Needle in holding position . . . . .	5		
<b>I and J</b>			
Increasing . . . . .	12—13		
Irregular texture . . . . .	19		
Joining wool ends . . . . .	9		
<b>K</b>			
Knitting aids . . . . .	2		
<b>L</b>			
Latch needles . . . . .	5		
Latches, bent . . . . .	17, 18, 19		
Lifting-off stitches . . . . .	12		
Lubrication . . . . .	18		
L-shape screw . . . . .	1		
<b>M</b>			
Maintenance . . . . .	18		
<b>N</b>			
Needle foot . . . . .	5		
Needle head . . . . .	7		
Needle latches . . . . .	17, 18, 19		
Needle position . . . . .	5		
Needle setter . . . . .	7		
Needle selector . . . . .	7		
Needle selection . . . . .	8		
Needle in upper working position . . . . .	5		
Normal knitting . . . . .	5		
Numbered rail . . . . .	6		
<b>O</b>			
Open cast-on . . . . .	13		
Openings . . . . .	11		

<b>P</b>			
Patent knitting . . . . .	9		
Patent patterns . . . . .	9, 20		
Pattern, colour- . . . . .	15		
Picking-up stitches . . . . .	9		
Plain knitting . . . . .	13		
Pocket holes . . . . .	10		

<b>R</b>			
R. Circular . . . . .	5		
Row Counter . . . . .	6		
Racking . . . . .	9, 19		
Racking patterns . . . . .	9, 19, 20		
Racking wheel . . . . .	6		
R.C. Return row counter to 000 . . . . .	5		
R.P. needle in rest position . . . . .	5		
Ripping back . . . . .	9		
Rest position . . . . .	5		
Round shaping . . . . .	10		
R.B. Rear needle bed . . . . .	8		
Rear needle bed . . . . .	8		
Re-hanging comb . . . . .	14		

<b>S</b>			
Semi-circular . . . . .	9		
Side weights . . . . .	7, 9, 13		
Sock, stockings . . . . .	15—16		
Slide . . . . .	5		
Slide rails . . . . .	6		
Shortened rows . . . . .	10		
Shaping in holding position . . . . .	10		
Stitch size control . . . . .	5		
Stitch type control . . . . .	5		
Starting position . . . . .	8		
Starting position of slide . . . . .	8		
Stitch formation . . . . .	7		
Stitch size . . . . .	5		
Stitch test . . . . .	2		
Stocking stitch bar . . . . .	7		

<b>T</b>			
Tension wire . . . . .	6		
Tension wire screw . . . . .	6		
Table . . . . .	2		
Transferring to hand needle . . . . .	12		
Transferring stitches . . . . .	10		
Taking-off . . . . .	11, 14		
Taking-off with circular . . . . .	12		

			Page
Taking-off unfinished edge . . . . .			9
Texture, irregular . . . . .			19
Toe . . . . .			16

<b>U</b>			
U.W. (needle in upper working position) . . . . .			5
Unpacking machine . . . . .			1
Upper working position . . . . .			5

<b>V</b>			
Vertical holes . . . . .			10
V. neck . . . . .			11

<b>W</b>			
Wool brake screw . . . . .			6
Weaving-patterns . . . . .			21
W.P. (working position) . . . . .			5
Working position . . . . .			5
Wool . . . . .			2
Weights . . . . .			7, 9, 13

<b>Y</b>			
Yarn breaks . . . . .			19

### Abbreviations

F.B. = Front needlebed	}	8
R.B. = Rear needlebed		
l = Needle working	}	5
. = Needle not working		
N = Normal knitting	}	on stich type control
P = Patent = (Fisherman's Rib)		
R = Circular	}	5
O = Free - wheeling of slide		
R.P. = Needle in Rest position . . . . .		5
W.P. = Needle in Working position . . . . .		5
U.W. = Needle in Upper Working position . . . . .		5
H.P. = Needle in Holding position . . . . .		5
R. = Racking		
— = Knit 1 row . . . . .		19
== = Knit 2 rows . . . . .		19
=== = Knit 3 rows . . . . .		19
==== = Knit 4 rows . . . . .		19

Printed In Switzerland