

Hobby Girl

Knitting Machine

Happiness is hours of fun making pretty things for everyone

With your Tomy Knitting Machine there are lots of attractive things you can easily make, using your own designs and favourite colours. This brochure contains some helpful ideas to start you off.

TOMY

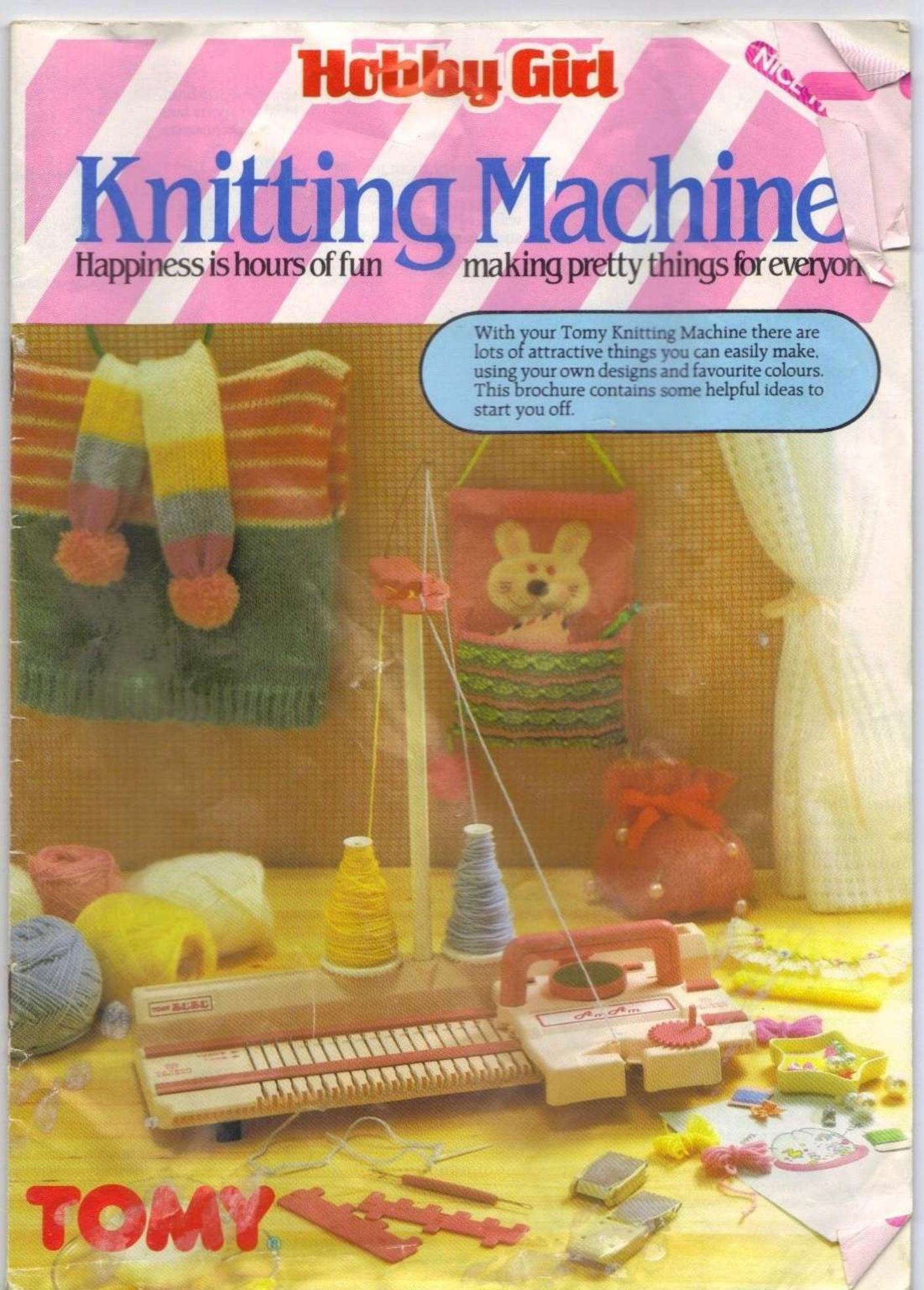



Looks good and feels comfortable. This stylish tanktop goes great with either trousers or skirt.

Knitted cap with attractive turned up brim. Ideal for sports fans and outdoor enthusiasts.

Don't worry about the cold weather. These pretty mittens will keep your hands snug and warm.

This cheerful and colourful striped waistcoat will look really cute, especially if you make the mittens to match.



Don't go to school without this super knitted satchel. Everyone in your class will want one!

No budding disco dancer should be seen without this gorgeous, beaded hair band.

I MADE THEM



Wrap up against the winter winds with this pom-pom scarf. With the waistcoat and mittens, You've got a complete winter outfit.



Happiness is hours of fun making pretty things for everyone.



ALL BY MYSELF.



Here's another handy way to beat the freeze, a scarf with pockets. Use alphabet buttons to feature your name or a catch phrase.



You'll set the scene at any party with this elegant purse with lovely lace trimmings.

Using pearl buttons and lamé trimmings, this is another design for a pretty party purse.

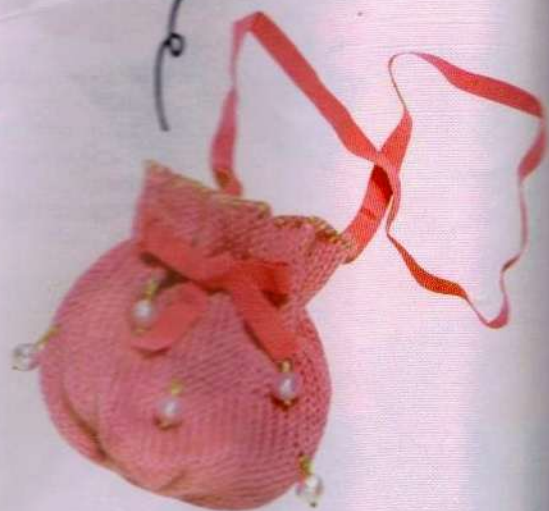

Here's an attractive way to keep your room neat and tidy. This pretty wall pocket is just the place for your bits and pieces.



This multi-coloured cushion with its big, natty pom-poms will brighten up any room.



This delightful Dachshound with its floppy ears will be a pet everyone will want to cuddle.



Surprise your father with these stylish golf club head covers, they'll make the perfect birthday or Christmas present.



This is your very own curly headed mascot sporting your favourite team's colours.



Index

Parts of your Machine	5	Hints and Tips	16
Contents	6	If the Carriage Jams	16
Types of Yarn to use	6	Unravelling a Row	16
How to set your Machine up	7	Dropped Stitches	17
The Needle Bed	7	Trouble shooting	17
How to Knit	8	Techniques	18
Row Counter	9	Ribbing	19
Winding Yarn	9	Project 1. Hat and Scarf set	20
Threading Your Machine	10	Project 2. Bag	21
Casting On	10	Project 3. Wall hanging	22
How to knit stitch patterns	11	Project 4. Cushion Cover	22
Casting Off	12	Project 5. Tuck stitch Bag	23
Stitch Patterns	13	Project 6. Tank Top	24

Parts of your Machine

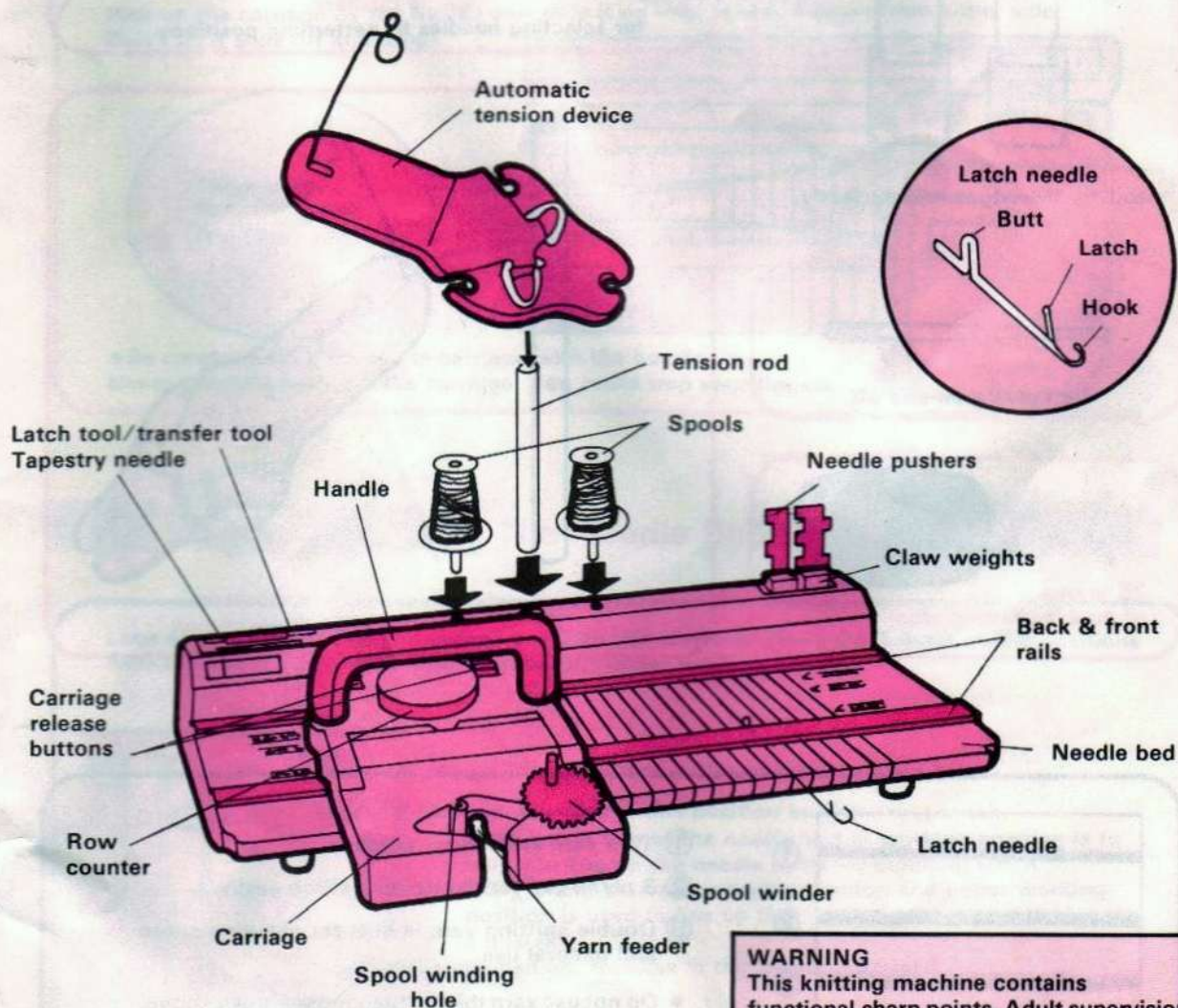

WARNING
 This knitting machine contains functional sharp points. Adult supervision is recommended when the machine is being used by children.

Contents

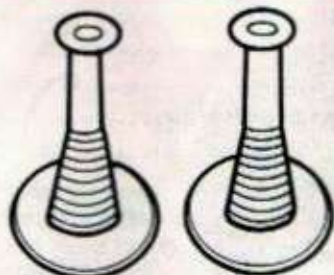

2 Spools



Latch tool
for ribbing and repair work.

Transfer tool
for transferring stitches

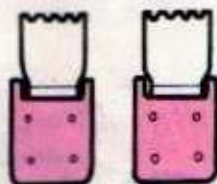

2 Claw weights
to help the edges knit perfectly.

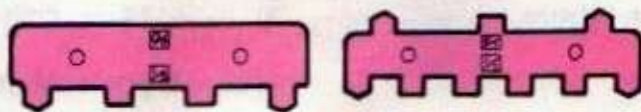

Needle pushers
for selecting needles to patterning positions.



Tapestry needle
for casting on and off.



25 grams
of double knitting wool



Tension rod



Automatic
tension device

Types of Yarn to use

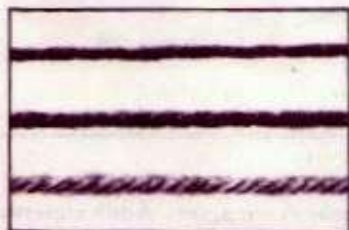

①

① Thin yarn knits loose stitches.

②

② 3 ply/4 ply yarn knits tuck stitch easily.

③

③ Double knitting yarn is best for stocking stitch and general use.

• Do not use yarn thicker than those shown above. It could damage your machine.

How to set your Machine up

Place the machine on the table like this.

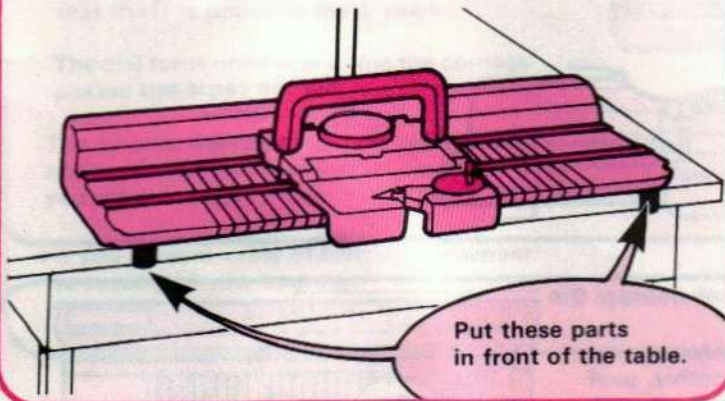

Pick up the carriage by the handle and slide it on rails. It will slide on from either side. Don't let it slide off and drop!

These parts fit on the front and back rails.

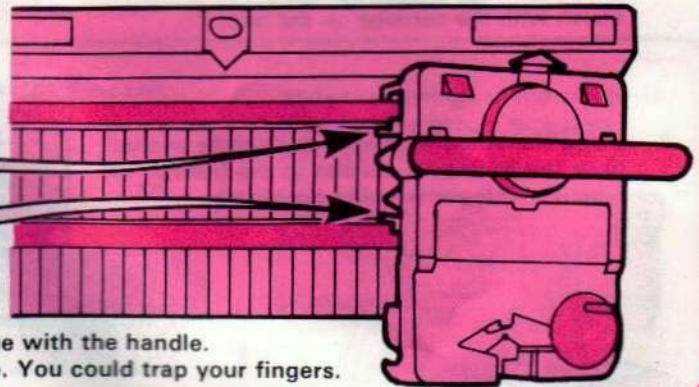

*Be careful, ONLY move the carriage with the handle. Never touch underneath the carriage. You could trap your fingers.

The Needle Bed

Look at your needle bed and compare it with this diagram. There are 3 main needle positions. Non-Working position, working position and upper working position.

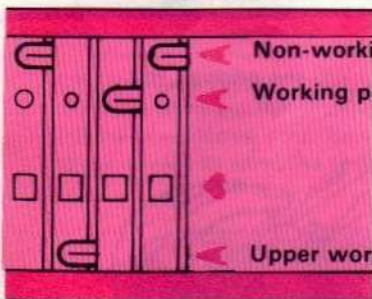

Non-working position: Needles in this position will not knit.

Working position: Needles in this position knit stocking stitch.

The ○ mark across the needle bed at working position is to help you line up the needle butts for stocking stitch.

The □ mark between working position and upper working position is used to line up the needle butts after repairing a mistake.

Upper working position: Needles in this position pattern.

How to Knit

Put all the needles in NON WORKING POSITION, then practice moving the carriage.

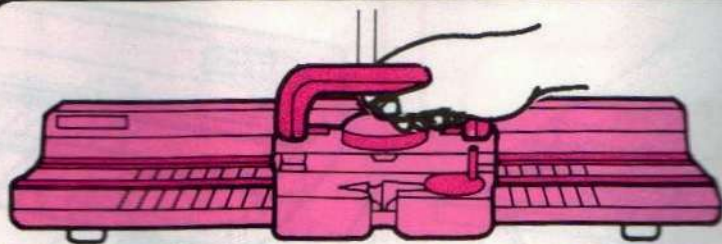

Hold the carriage by the handle, pressing down lightly.

Row counter trip

- 1 With the needles still in non-working position practice moving the carriage smoothly, past the row counter trip and back again several times.

Take care not to push the carriage off the end! If you do, slide it back on again. Finish with the carriage on the left.

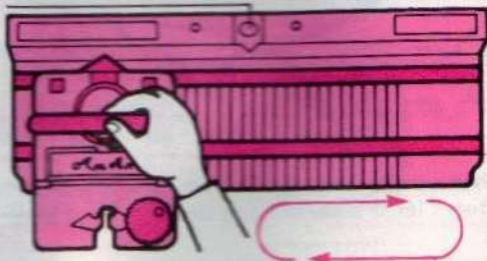

- 2 Using the straight edge of the needle pusher push the centre 15 needles to the front of the machine. (Upper working position.)

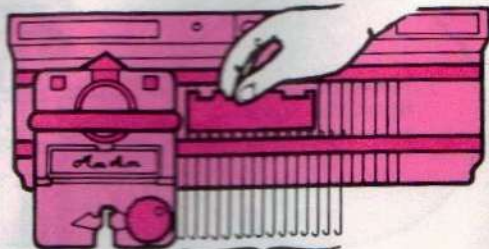

15 needles

- 3 Move the carriage smoothly to the right. When it has cleared the last needle you will hear a 'click' then you can knit to the left.

The needles will automatically return to working position. Check they are in a straight line.

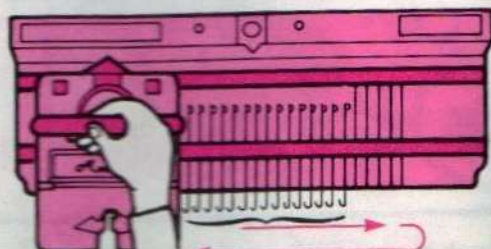

Check you clear the last needle. "listen for the 'click'"

Practice moving the carriage smoothly from side to side several times.

- *If you don't clear the last needle the carriage will JAM.



TAKE CARE! the ends of the needles are sharp!



Always return your needles to Non-Working Position when you have finished knitting.

The Row Counter

Row counter trip

To set the row counter turn the dial so that the 0 is opposite the ▲ mark.

The dial turns once every time the carriage passes the trip.

The counter counts to 30 and then starts again. Make a note to help you remember if you are knitting more than 30 rows.

• If you unravel a row of knitting remember to reset your row counter.



0 opposite ▲



the dial turns once every row.

To help 'bed in' the knitting machine parts we suggest that you move the carriage backwards and forwards several times until it moves smoothly.

Don't use yarn from a hank or a hand wound ball; wind it on the spool first. Put the Yarn in a container as shown.



Put the spool into the spool hole on the carriage.

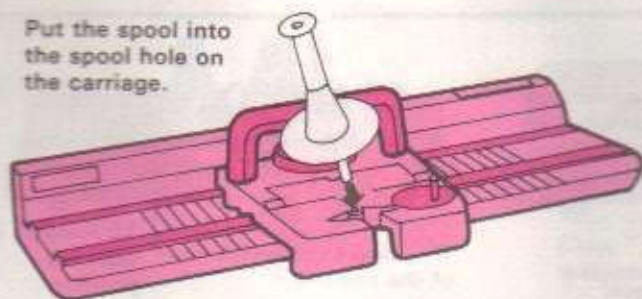

Clip the yarn on the spool, then hold the yarn with your left hand and turn the handle. Move your hand up and down slowly to wind the spool evenly.



Slide the carriage to the centre of the machine before you start winding.

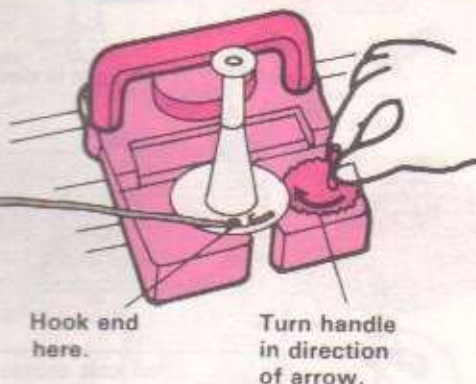
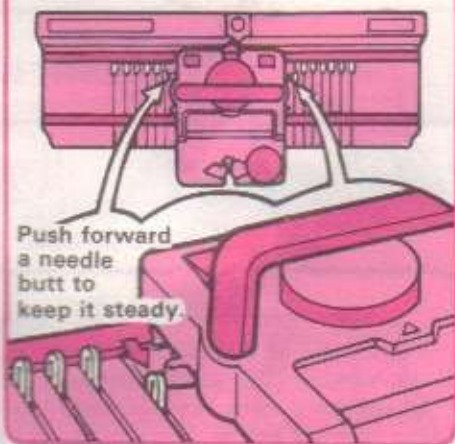

Threading Up

Set up your machine as shown in the diagram. Push 15 needles to working position and have your carriage on the left.

Thread your yarn through the tension device in order 1. 2. 3. 4. and 5.

How to thread the yarn feeder.
Stage 5.

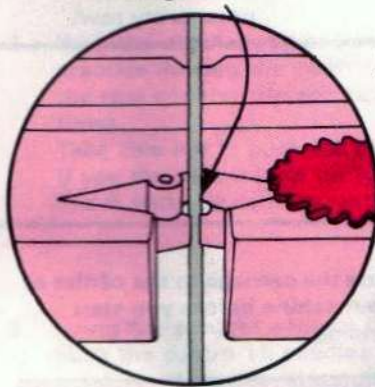

Carriage on the left

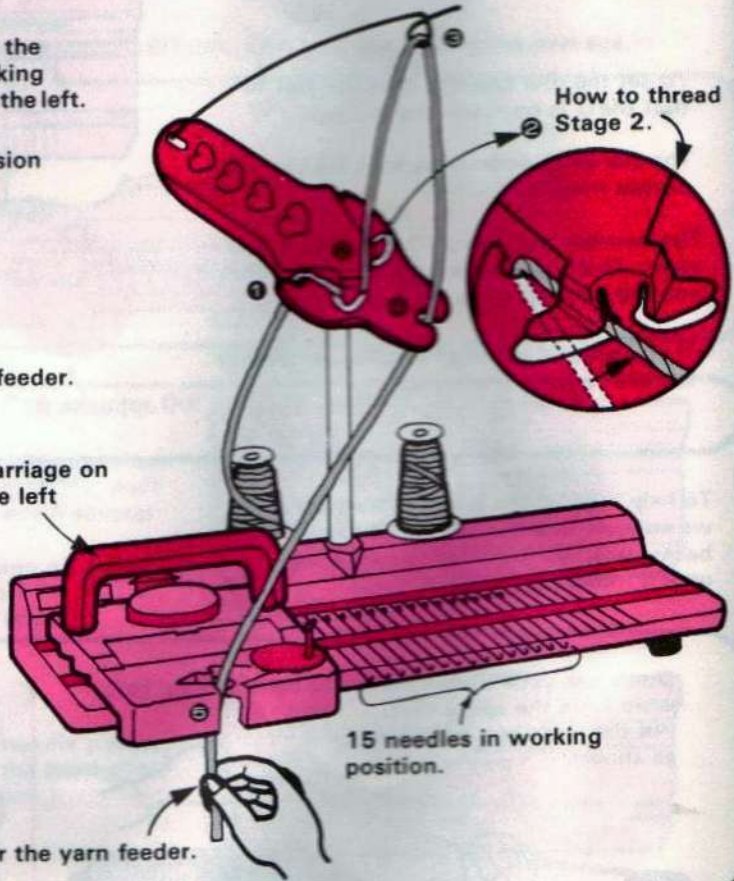

Hold the yarn under the yarn feeder.

Casting On

Pull an end of yarn about $1\frac{1}{2}$ times the width of the knitting (15 needles) through the yarn feeder. Check the yarn is not too slack, then still holding the yarn below the carriage, move the carriage from left to right.

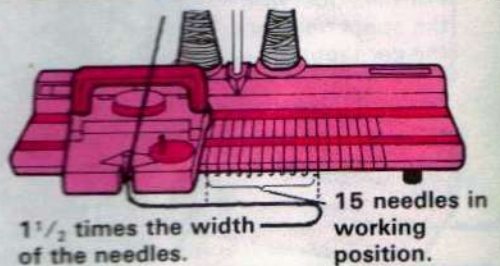

If the yarn is slack here.

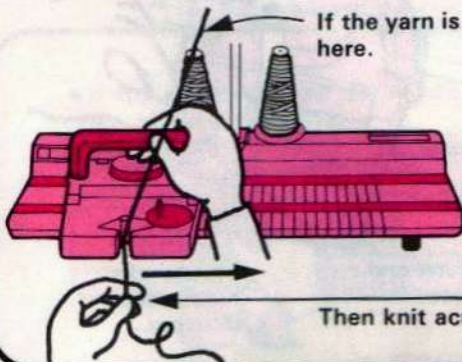

Pull a little more through the yarn feeder.

Then knit across.

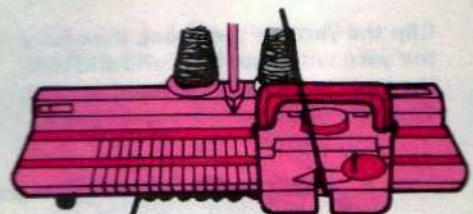

The yarn will make a zig zag row as shown.

Take the loose end of yarn and bind the zig-zag row as shown start at 1 and continue to the end 15

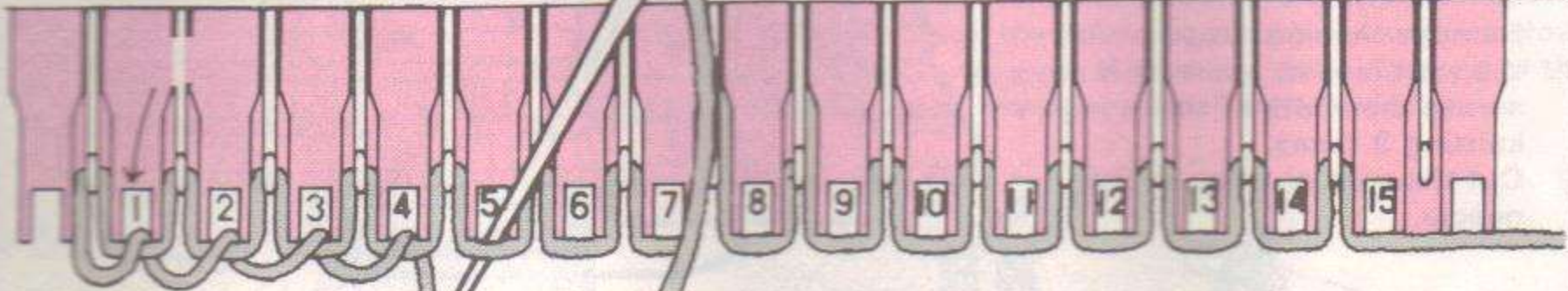
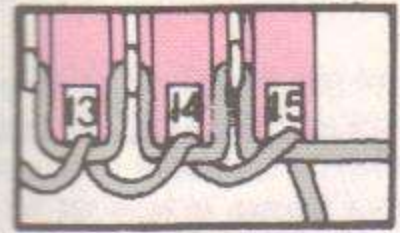

It's easier to thread the needle if

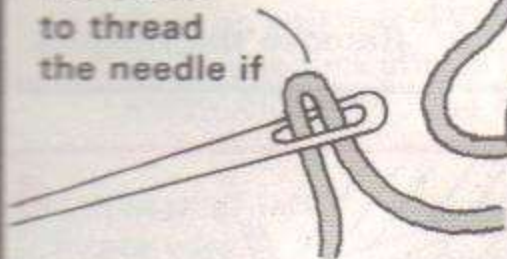

you double the thread

When you reach the end 15 leave about 10cm spare and cut off any extra yarn. Using the needle pusher line up your needle butts in working position ready to knit.

Knitting Stocking Stitch

1 Set the row counter to 0. Move the carriage smoothly from side to side. (Remember, listen for the click) If you move the carriage too far from the edge of the knitting the yarn may become too slack. Pull it back behind the tension rod.

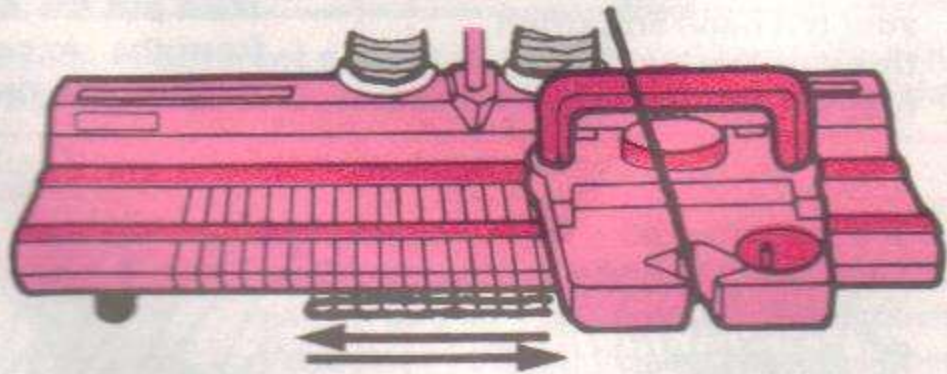

2 After a few rows hang the claw weights as shown in the diagram. They help the edge stitches to knit

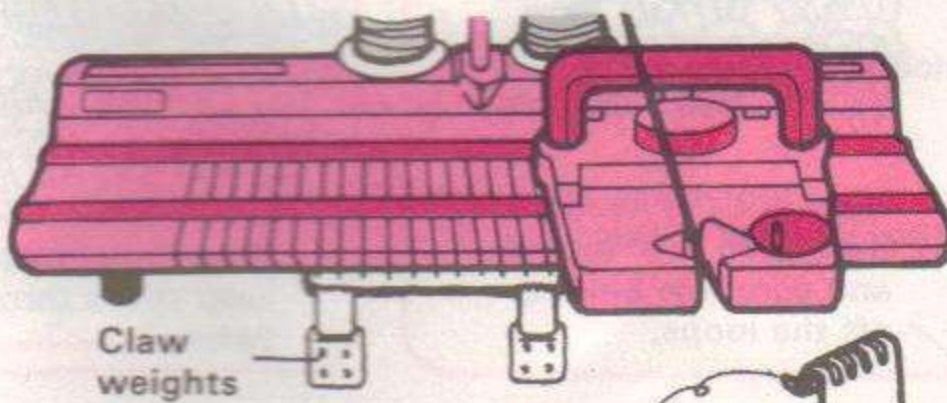

TAKE CARE

The claws are sharp

3 Continue knitting, move the weights up every 20 rows or so. Hang the weights evenly. Knit about 30 rows.

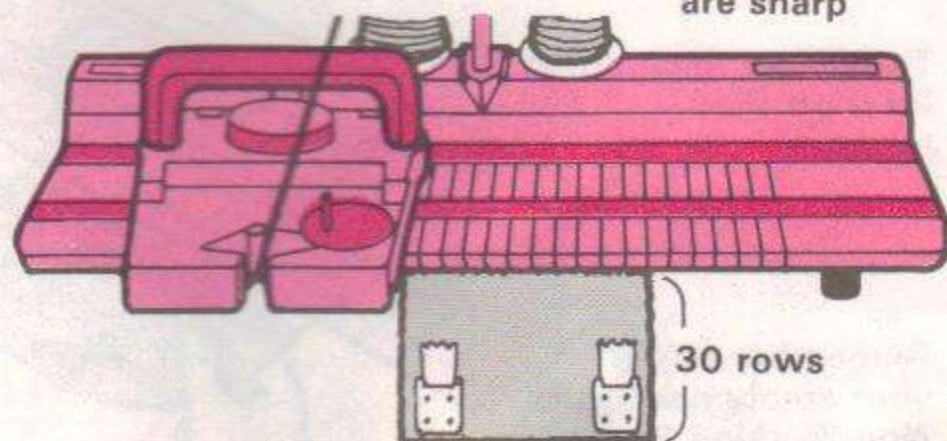

Casting Off

When you are ready to cast off first remove the weights!

Close edge cast off

Remove the yarn from the yarn feeder. Measure it across the width of the knitting 3 times. Cut the yarn and thread the needle.

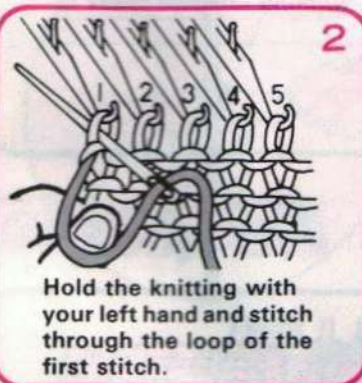
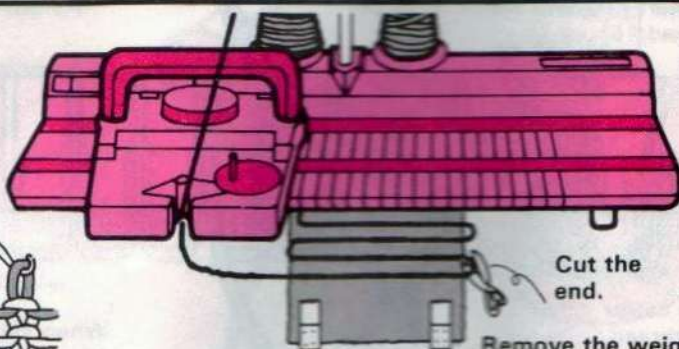
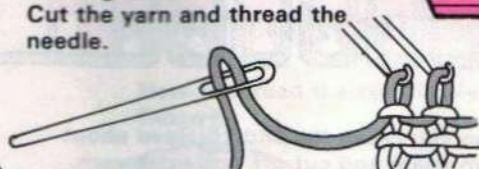

Hold the knitting with your left hand and stitch through the loop of the first stitch.

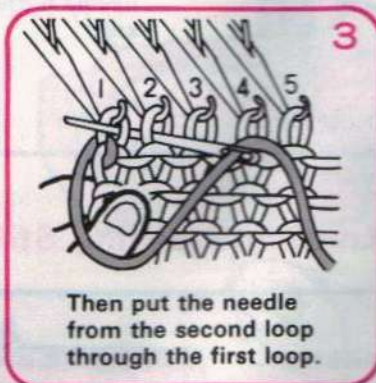

Then put the needle from the second loop through the first loop.

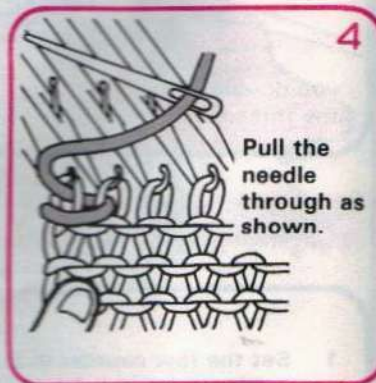

Pull the needle through as shown.

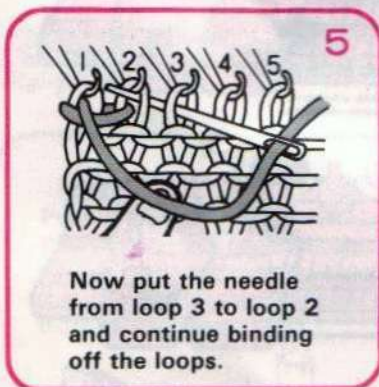

Now put the needle from loop 3 to loop 2 and continue binding off the loops.

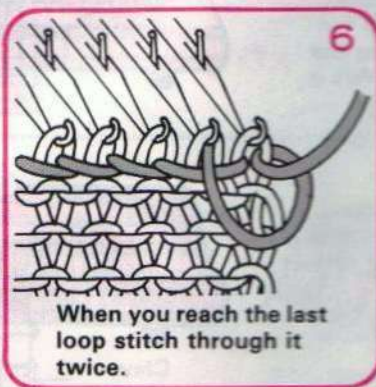

When you reach the last loop stitch through it twice.

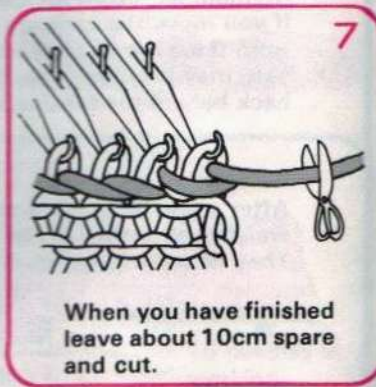

When you have finished leave about 10cm spare and cut.

To remove the knitting lift it off the hooks.

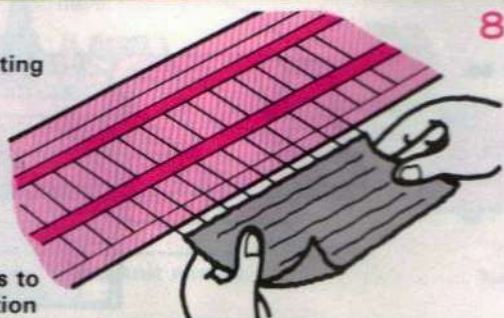

Remember to put your empty needles to Non-Working Position

Open edge cast off.

If you want to remove the knitting without casting off simply take the yarn from the yarn feeder and move the empty carriage across the needle bed.

Stitch Patterns

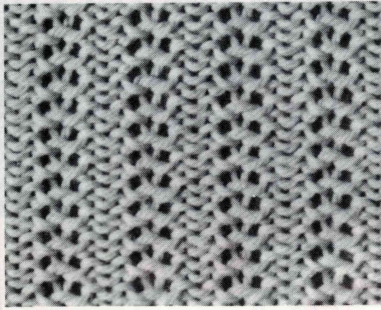

When a needle is pushed to upper working position it will not knit. Instead a loop of yarn is made over the needle. You can use your needle pusher to push selected needles to upper working position and use the loops to form patterns. This technique is called tuck stitch. The thinner the yarn the more open and lacy the effect. As you will see when you knit the following samples changing colour makes this technique even more interesting. Either the purl or the plain side can be used as the right side of the fabric.

- 1 Cast on and knit 5-6 rows stocking stitch. Hang your weights. Decide whether you want to knit 1 or 2 rows tuck stitch. If you want 1 row tuck stitch have the carriage on the left. For 2 rows tuck stitch move it to the right.

Carriage at left
1 row tuck

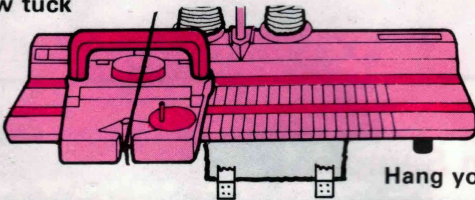

Carriage at right
2 rows tuck

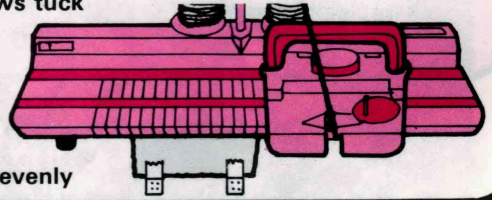

Hang your weights evenly

- 2 Look at your needle pushers. Each side selects different groups of needles to Upper Working Position. Look at your needle bed. It is marked A. B. C. D. across the bed to help you select the right needle.

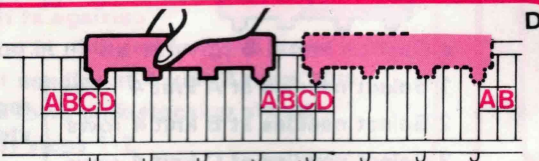
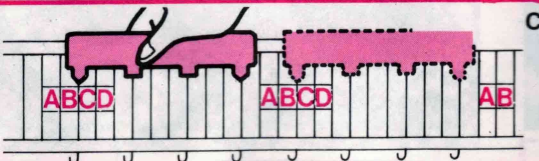
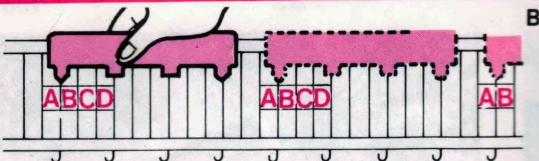
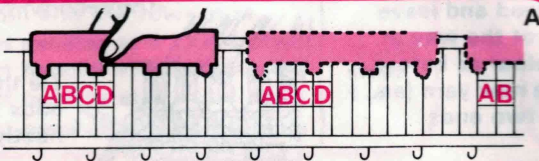

Let's try the $\frac{1}{2}$ needle pusher and A position needles. Place the tooth of the needle pusher to the left of A and push the butts of the needles forward to upper working position. Repeat across the needle bed.

(To select needles at B, C, or D, position you would use the same method.)

NOTE

When selecting needles steady your knitting with your hand so that it doesn't slip off.

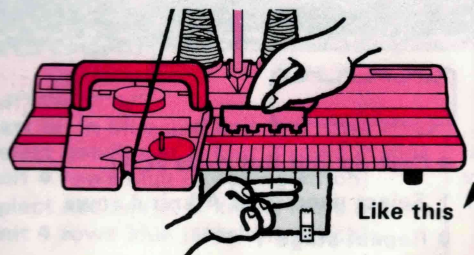

3 Now knit according to the side the carriage is on; if the carriage is on the left knit 2 rows 1 row will tuck the second row knit.
If the carriage is on the right knit 4 rows 2 rows will tuck the other two will knit.

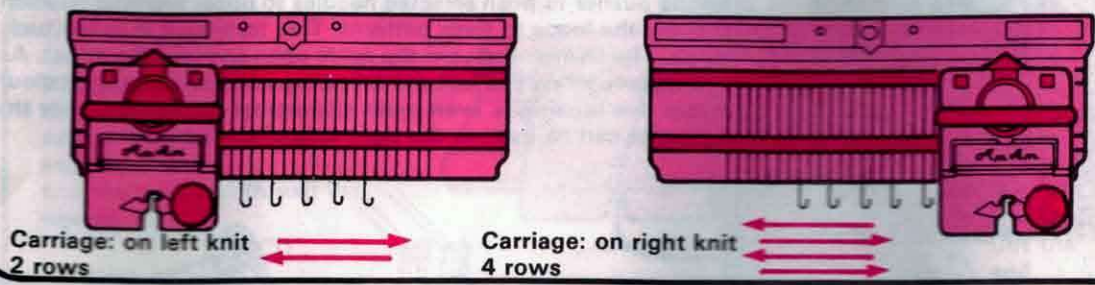

Select needles at A as before and repeat watching carefully how the stitch pattern forms. As you will see the 'Tucking needle' needs a needle knitting stocking stitch on each side. Now continue either repeating with needles at A or select needles at B C or D. Then try the samples below.

Stitch Pattern Samples

- * Always knit 5-6 rows before starting patterns.
- * Hang your weights evenly.
- * When changing colour wind your spool as before and thread up page(10). Unthread the 1st colour from the yarn feed and leave approx: 10cm spare before you cut it. Clip it out of the way at of your tension device. Thread up your second colour as before and rethread your yarn feeder. Hold the end of the new yarn (as you do when casting on) for the 1st row. Tie the two ends together neatly.

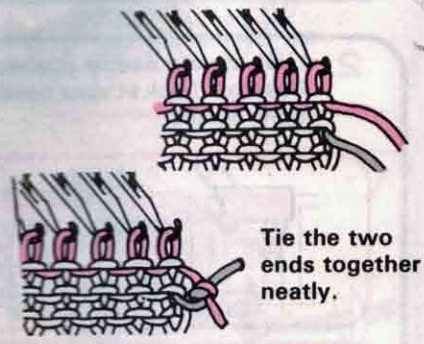

Tie the two ends together neatly.

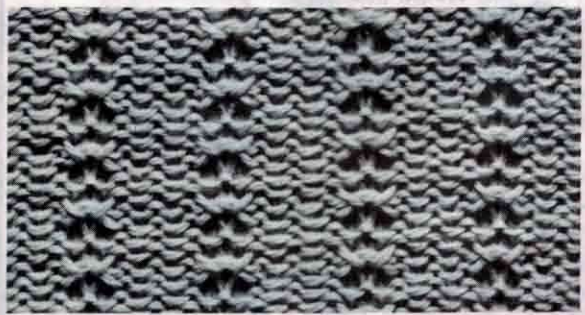

$\frac{1}{3}$ needle pusher carriage at right

- * Cast on knit 5-6 rows st. st.
- 1 Select needles at A knit 4 rows
- * Repeat stage 1



$\frac{1}{2}$ needle pusher carriage at right

- * Cast on knit 5-6 rows st. st.
 - 1 Select needles at A knit 4 rows
 - 2 Select needles at B knit 4 rows
 - 3 Select needles at C knit 4 rows
- } repeat steps 1-3

Note: st. st. - stocking stitch

Note: st. st. - stocking stitch

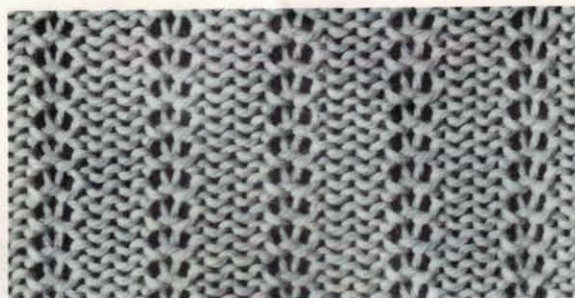

$\frac{1}{3}$ Needle pusher carriage at the left.

- * Cast on. Knit 5-6 rows st.st.
- 1 Select needles at A knit 2 rows
- * Repeat step 1

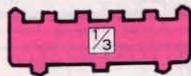
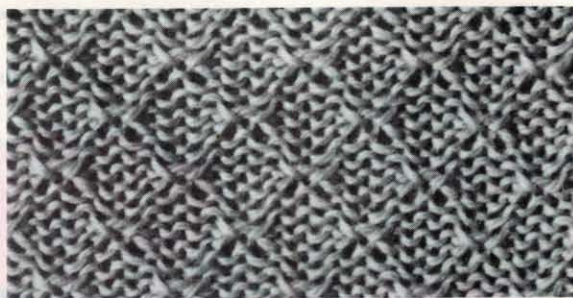

$\frac{1}{3}$ Needle pusher carriage at the right.

- * Cast on knit 5-6 rows st.st.
- 1 Select needles at A knit 4 rows
- 2 Select needles at C knit 4 rows
- * Repeat steps 1 and 2

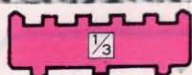

$\frac{1}{3}$ Needle pusher carriage at the right.

- * Cast on knit 5-6 rows st.st.
 - 1 Select needles at A knit 4 rows
 - 2 Select needles at B knit 4 rows
 - 3 Select needles at C knit 4 rows
 - 4 Select needles at D knit 4 rows
- } repeat steps 1-4

Front

Back

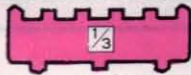
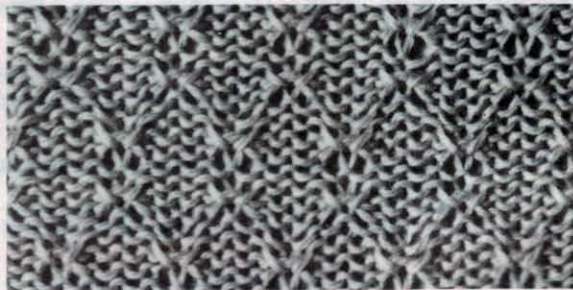

$\frac{1}{3}$ Needle pusher carriage at the right.

- * Cast on knit 5-6 rows st.st.
 - 1 Select needles at A knit 4 rows
 - 2 Select needles at A knit 4 rows
 - 3 Select needles at C knit 4 rows
 - 4 Select needles at C knit 4 rows
- } repeat steps 1-4

Front

Back

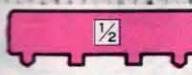
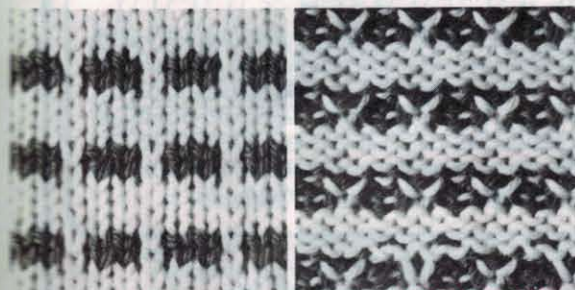

$\frac{1}{2}$ Needle pusher carriage at the right. Pink and Blue yarn

- * Cast on in pink and knit 5-6 rows st.st.
- 1 Select needles at A knit 2 rows blue.
- 2 Knit 4 rows pink(stocking stitch)
- * Repeat steps 1-2

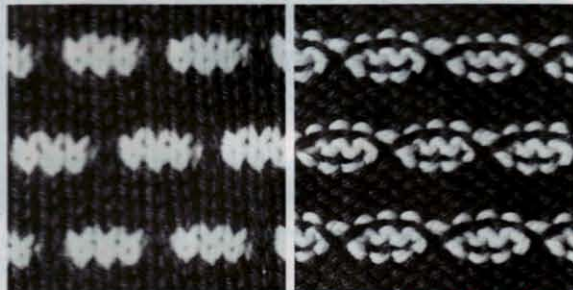

$\frac{1}{3}$ Needle pusher carriage at the right.

- * Cast on in blue and knit 5-6 rows st. st.
 - 1 Select needles at A knit 2 rows in pink
 - 2 Knit 4 rows blue (stocking stitch)
 - 3 Select needles at C knit 2 rows in pink
 - 4 Knit 4 rows blue (stocking stitch)
- } repeat steps 1-4

If the carriage jams don't force it. Get an adult to help you follow the instructions below.

1 To remove the carriage



Unthread the yarn feeder and remove your weights.

- * Don't worry if the carriage jams. Remove the carriage as in Diagram 1-3
- * Replace the carriage at the start of the row and unravel the stitches back to the carriage side (see below how to unravel).
- * Straighten the needles, rethread the yarn feeder and rehang your weights.
- * Pull back any slack yarn and you are ready to knit.

2 Press one of the carriage release buttons and lift the carriage up from the backrail.

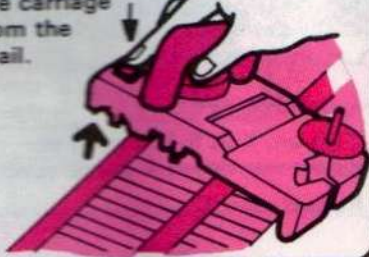

3 and forward clear of the needle bed.

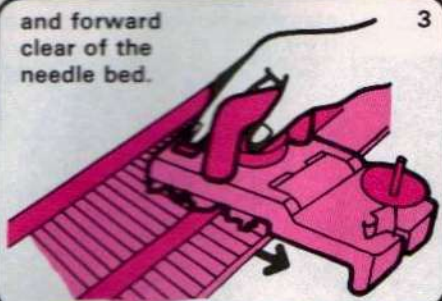

Unravelling a Row

- * Make sure all the stitches are in the hooks. * Use your transfer tool to replace them if necessary.
- * Unravel a few stitches at a time until you have completed the row

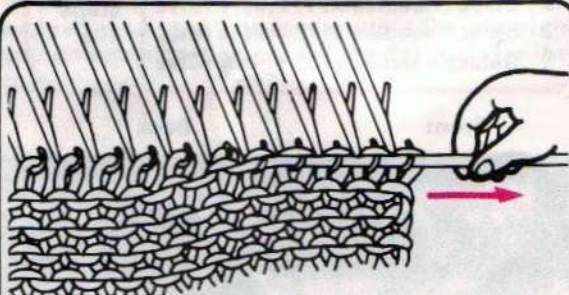

Hold your knitting down with your left hand and pull the yarn sideways with the other hand.

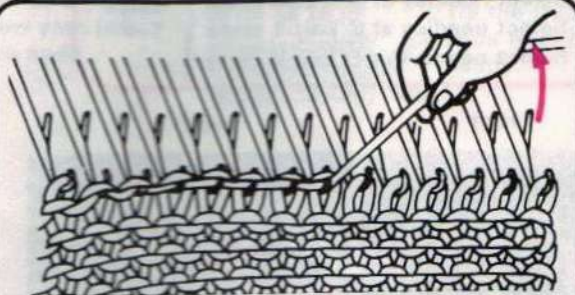

Lift the yarn upwards and backwards sliding the stitch of the row below into the hook.

- * Line up the needle butts in working position for stocking stitch. Stitches in hooks! Needles at the front of the needle bed should be lined up with their butts at the mark for stocking stitch. Stitches behind latches! or selected to upper working position for patterning.

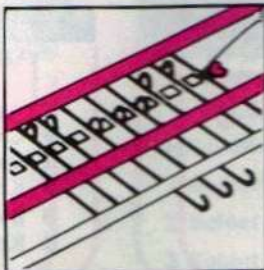

Replace needles for stocking stitch here (stitches behind latches.)

Pull back slack yarn

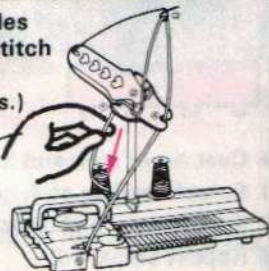

Dropped Stitches

To pick up a dropped stitch use your transfer tool.

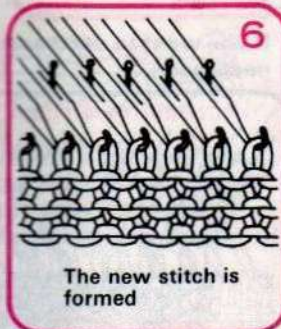
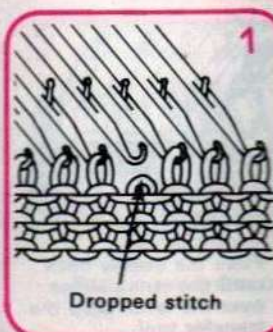
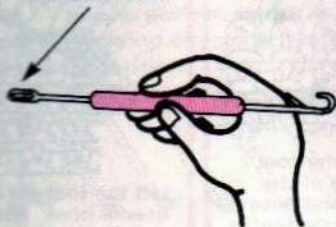

Trouble Shooting Guide

If you have problems check these points.

If the carriage is stiff or Jams

- 1 Is your yarn too thick? Look at page 6.
- 2 Is the yarn caught up? It must run freely. Check page 10.
- 3 Is your spool badly wound? If it is too tight or loose the yarn flow will be jerky.
- 4 Is there a knot in your yarn caught in the tension device or yarn feeder? If you are using two colours have they got twisted?
- 5 If the carriage jams suddenly look to see if the butt of a needle is out of position. The needle butts **MUST** line up with working position, non-working position or upper-working position to allow the carriage to move over them.

If you keep dropping stitches

- 1 If you drop stitches at the side have you hung your weights evenly?
- 2 Are you moving your carriage too far from the edge of your knitting? This causes a slack loop of yarn and dropped stitches when you knit.
- 3 Check your yarn flow. Is your tension device threaded correctly. (This is the usual problem)

* Clean your machine regularly with a small soft brush. Do NOT use Cleaning Fluids.

Techniques

Decreasing — one stitch at a time.



Place the transfer tool into the needle hook and pull forward until the stitch slides behind the latch.

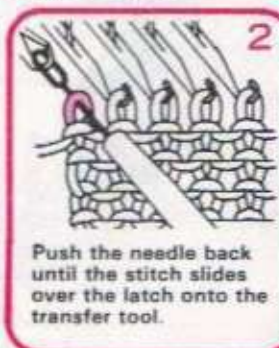

Push the needle back until the stitch slides over the latch onto the transfer tool.

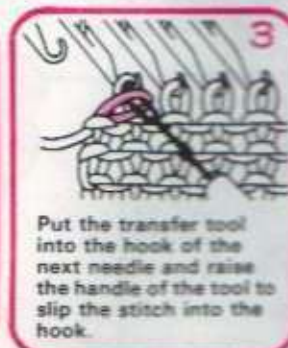

Put the transfer tool into the hook of the next needle and raise the handle of the tool to slip the stitch into the hook.

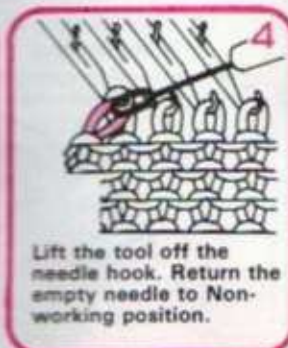

Lift the tool off the needle hook. Return the empty needle to Non-working position.

If you want to decrease several stitches knit the two loops together by hand at stage 4 and repeat as necessary.

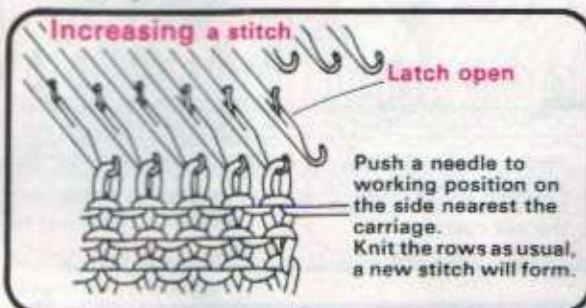

Push a needle to working position on the side nearest the carriage. Knit the rows as usual, a new stitch will form.

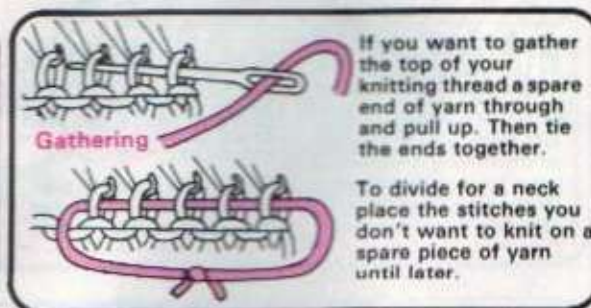

If you want to gather the top of your knitting thread a spare end of yarn through and pull up. Then tie the ends together.

To divide for a neck place the stitches you don't want to knit on a spare piece of yarn until later.

To make a hole: to use for a button hole or decoration

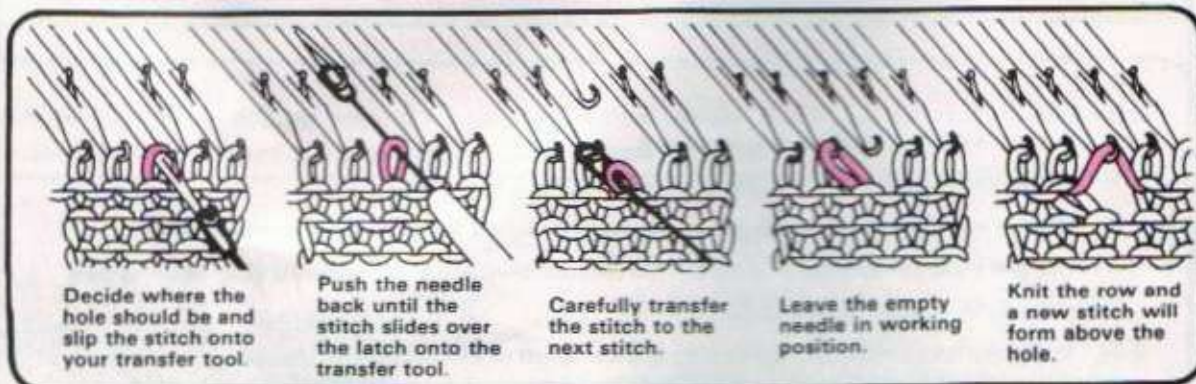

Sewing Up — Use a thin yarn of the same colour.

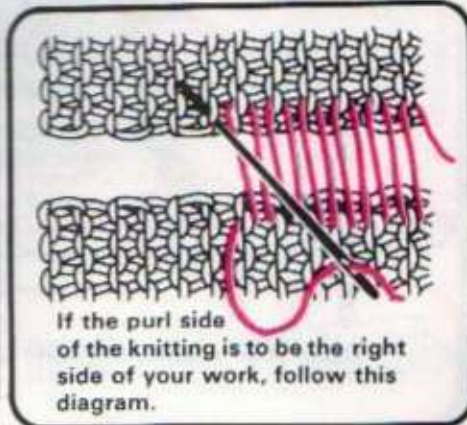
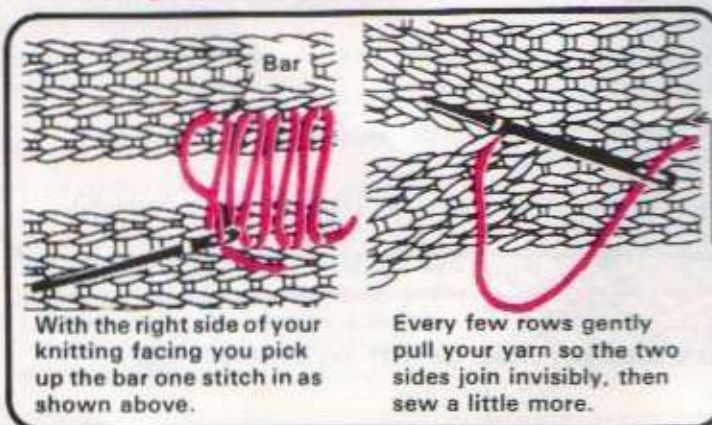

Cast On

- 1 Push needles to working position. Using the $\frac{1}{2}$ needle pusher, return the third and every following alternate needle to Non-Working Position.

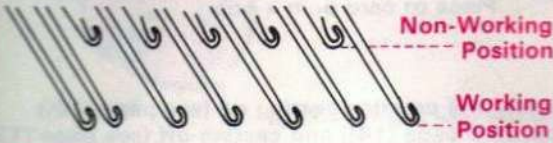

- 2 Thread up and knit the zig zag row as usual. Now take a piece of yarn in a different colour twice as long as the width of your knitting.

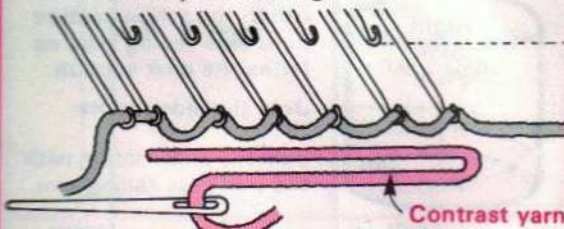

- 3 Bind off the zig zag row exactly as you would for an ordinary cast on.



- 4 Knit 3 rows



- 5 Push the needles in non-working position to working position.

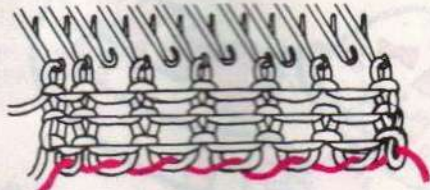

- 6 Knit the number of rows you want to be in rib.

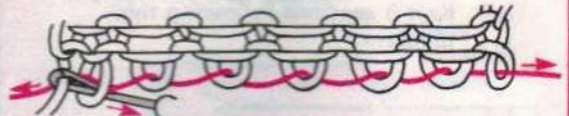

- 7 Hold the contrast yarn at both ends and pull down so you can see the bottom loops clearly. Pull the end of the main yarn through the first loop.

- 8 Drop the 3rd stitch from the end and ladder it down with your finger.

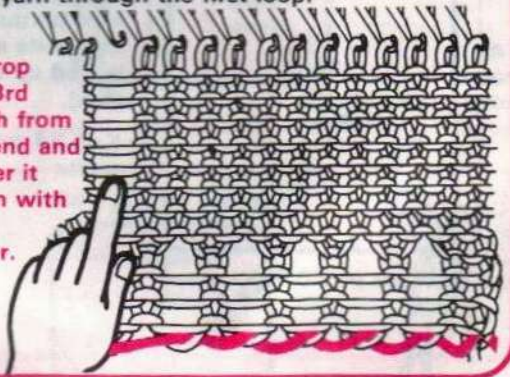

- 9 Use your latch tool to pick up and rib up the ladder you have made.

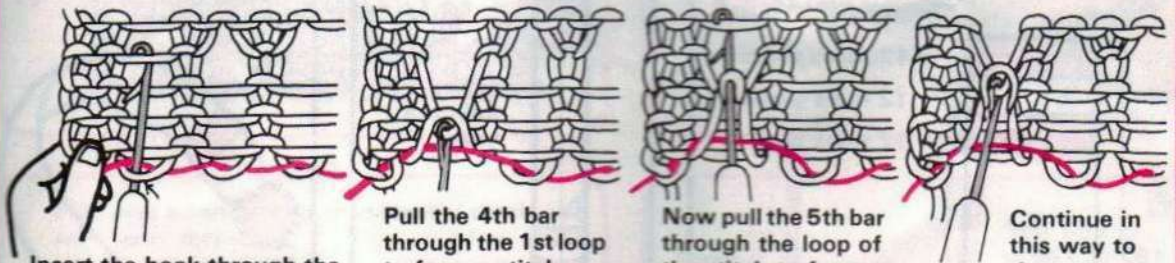

Insert the hook through the bottom loop and then up to catch the 4th bar. At the top slip the stitch onto the empty hook. Continue in this way across your work to the end. The rib is then complete. Pull out the contrast yarn.

Pull the 4th bar through the 1st loop to form a stitch.

Now pull the 5th bar through the loop of the stitch to form the next stitch.

Continue in this way to the top.

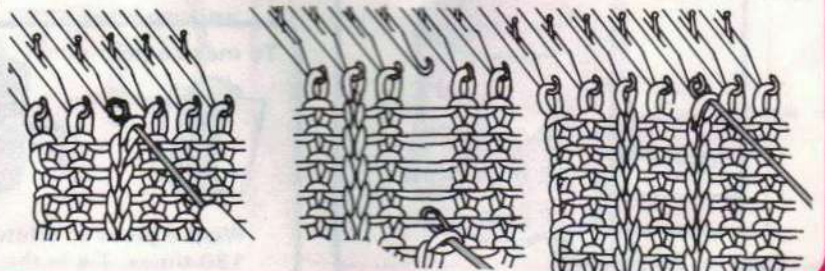

Project 1 Hat and Scarf Set

Materials:

Hat: White 20 gms pink 10 gms
Beads, sequins or pretty buttons

Scarf: white 30 gms pink 20 gms
Piece of card 6cm x 5cm

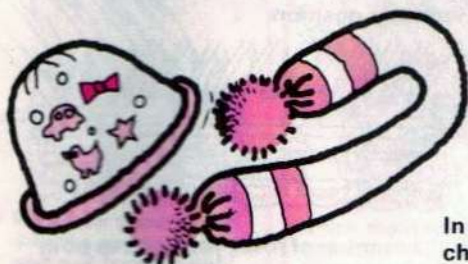

In this project you will practice casting on (see page (10))
changing colour (see page (14)) and casting off (see page (12)).

Hat: Knit 3 sections following this diagram. **1**

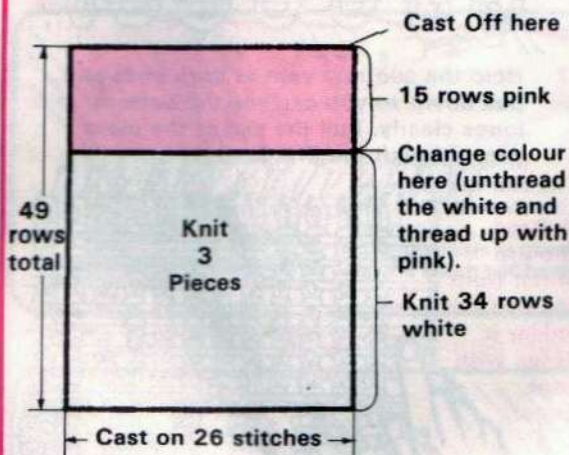

Join the sections like this **2**

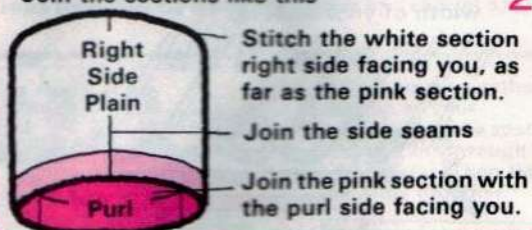

Gather the top **3**



Sew on sequins, beads, or pretty buttons.

Roll the pink section outwards for the brim and catch down.

Scarf

Cast off here **1**

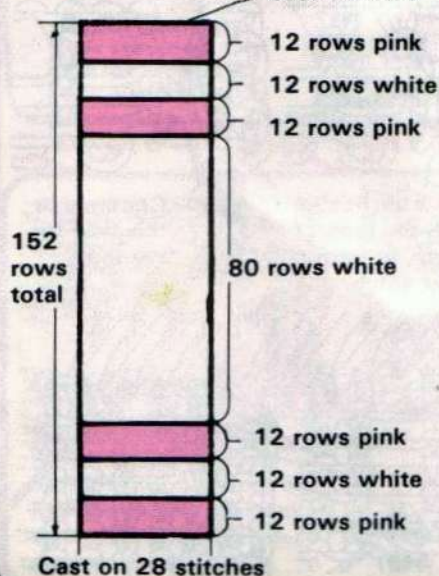

2

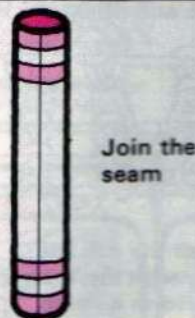

Gather both ends of the scarf. **3**

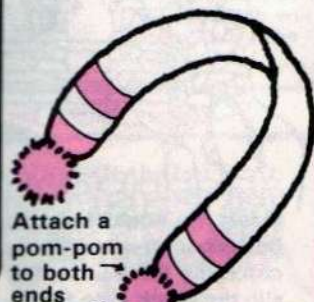

To make a pom-pom

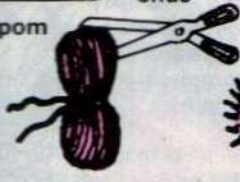

Wind a piece of white yarn round the card about 130 times. Tie in the middle and cut.

Project 2

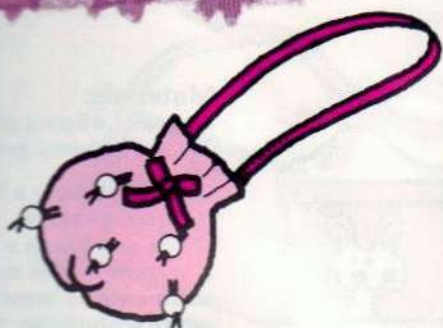

Bag

Materials:
 approximately 30 gms double knitting wool
 1 metre wide ribbon
 60cm narrow ribbon
 8 beads approximately 1.5cm in diameter
 A little lurex thread

In this project you will practice making a row of holes.

1

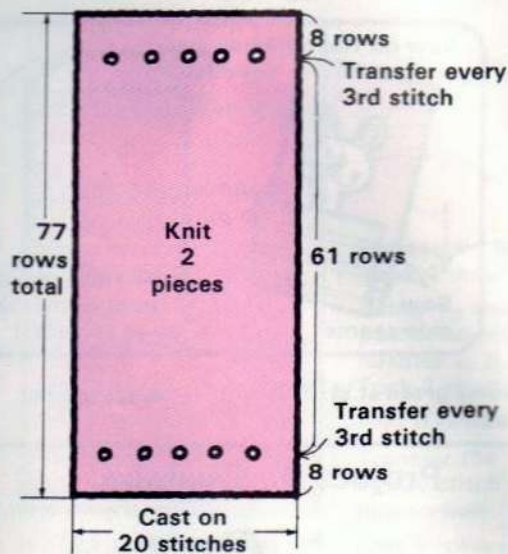

Transfer every 3rd stitch like this.

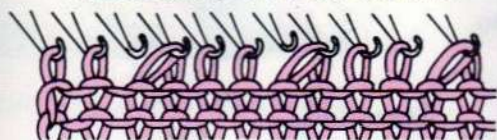

Sew the 2 pieces together fold in half and join the side seams.

2

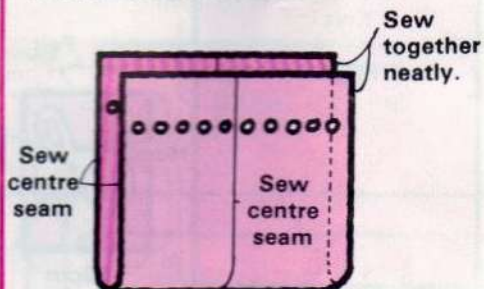

Sew on the beads

3

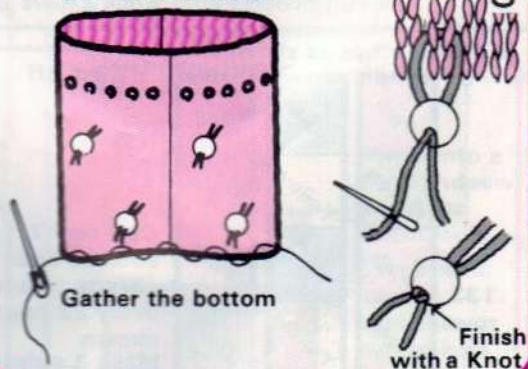

Fold over a narrow hem then blanket stitch with lurex thread.

4

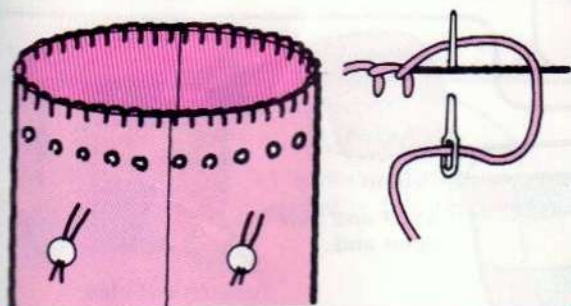

Lurex thread

Sew on the wide ribbon to form a strap.

5



Project 3 Wall Hanging with tuck stitch strips

This project includes Tuck stitch. See page 13

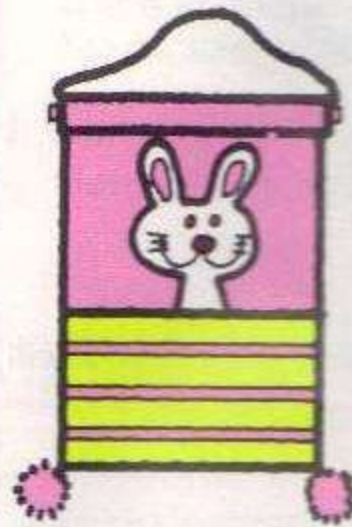
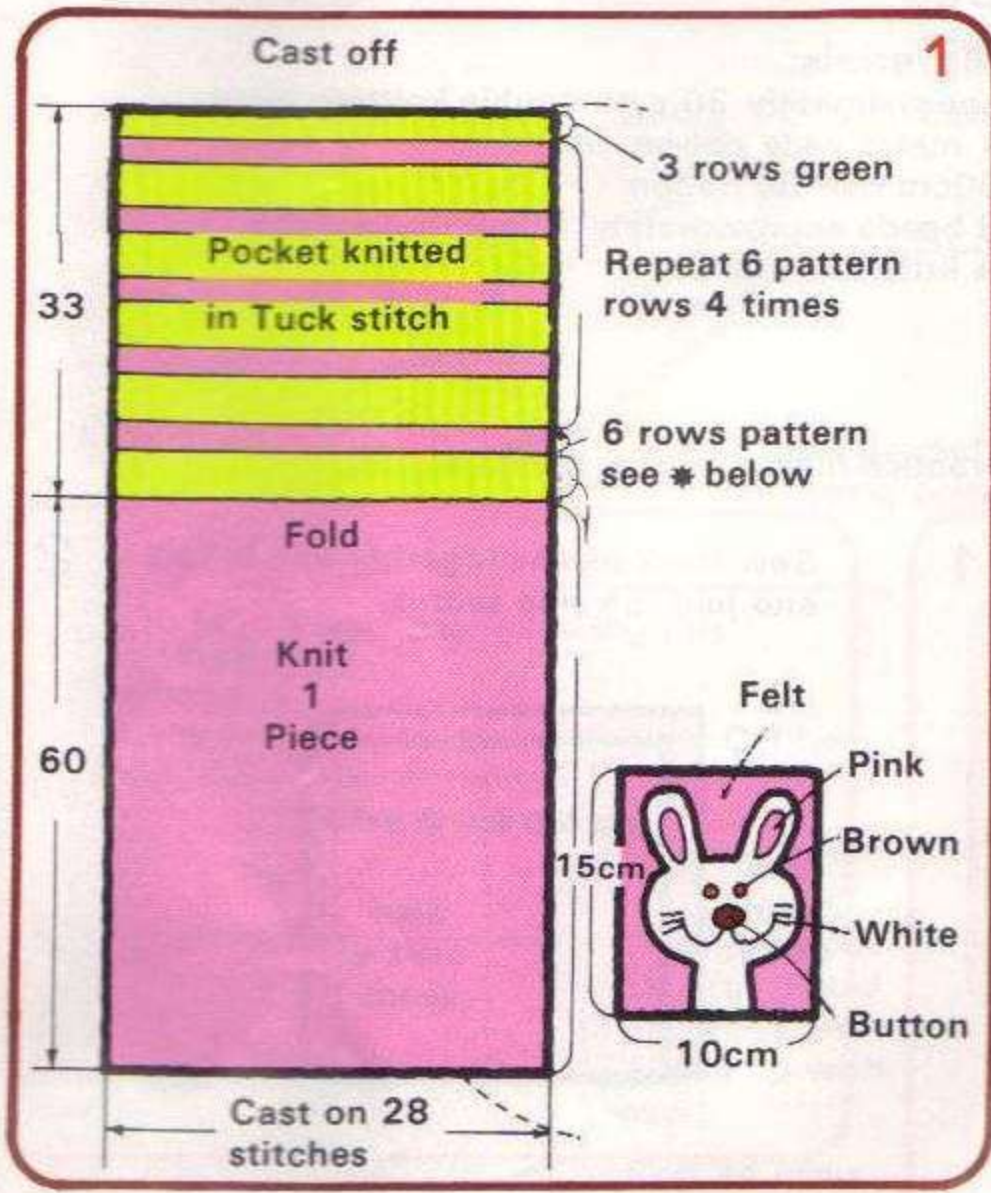

Materials:

Approx.: 45gms pink
10gms green

Cardboard 5cm x 5cm to make bobbles.
White felt 15cm x 10cm
A button for his nose
oddments of brown and white embroidery thread,
a piece of stick approx. 20cm.

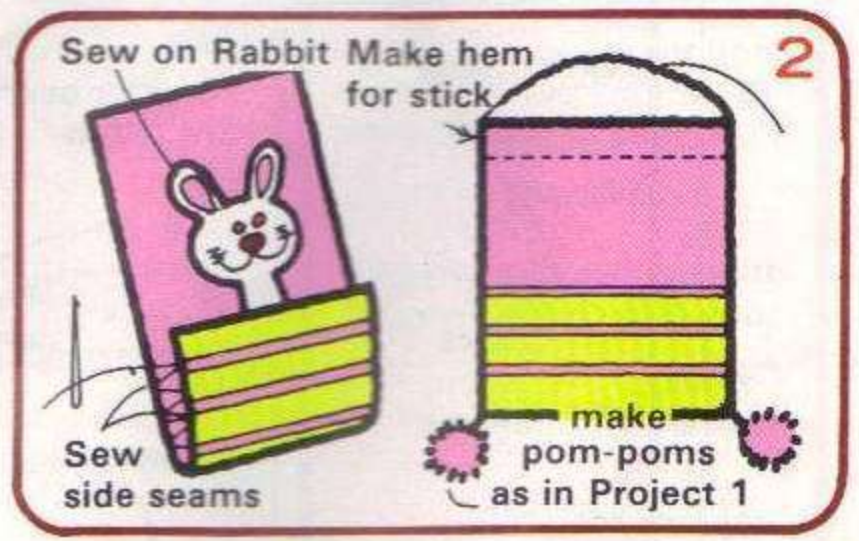

*Tuck Pattern instructions:- Carriage at right. 1) Knit 4 rows green st.st. 2) Using $\frac{1}{3}$ needle pusher select needles at A. Tuck 2 rows pink. Repeat.

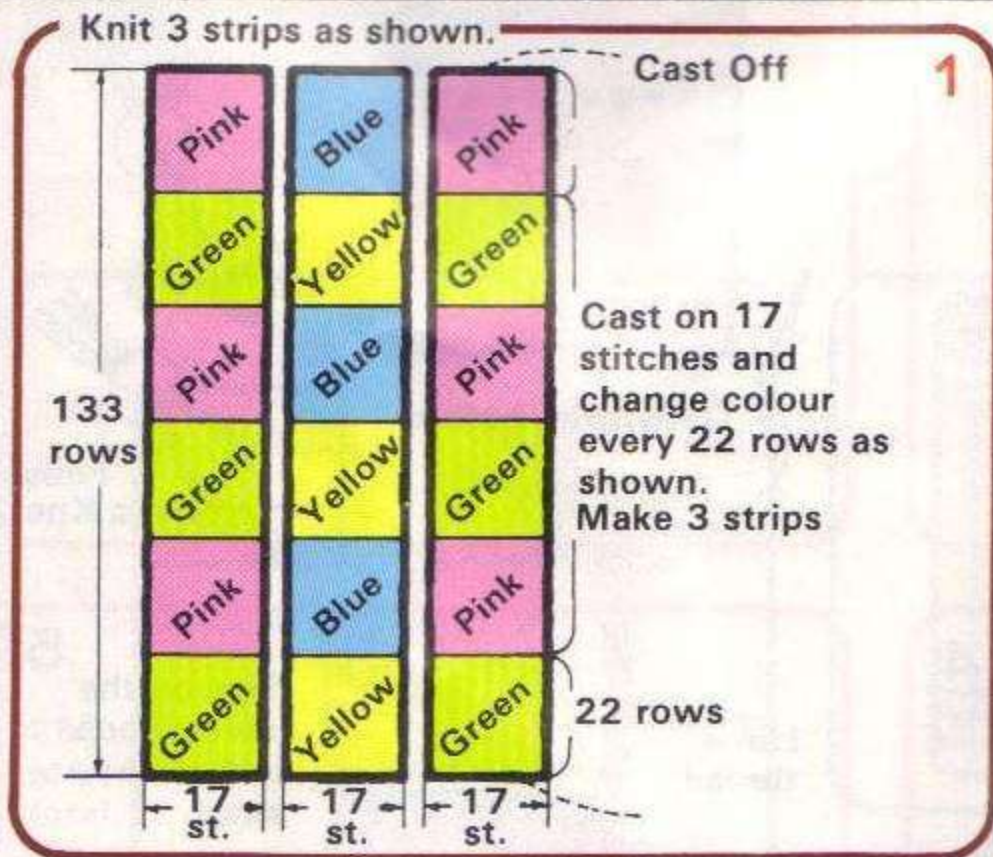

Project 4 Cushion

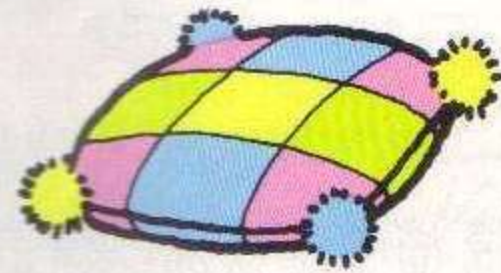

Materials:

Yarn quantities:
Pink 45gms Green 45gms
Blue 25gms Yellow 25gms
Cardboard 7cm x 5cm for bobbles
1 packet of Kapok.



Project 5 Tuck stitch Bag



This project has a button-hole and Tuck stitch trim.

Button-hole see page 18

Tuck stitch see page 13

Materials:

Double knittingwool.

Approximately 30gms red and an oddment of blue.

A button approx: 1.2cm in diameter.

Purse **Cast Off**

67 rows total

Knit 13 rows red

Repeat the last 10 rows 4 times

Using $\frac{1}{2}$ needle pusher select needles at A.

Tuck 2 rows.

Knit 8 rows red

Transfer the centre stitch for button-hole.

Knit 4 rows red.

Cast on 27 stitches

13 st. 1 st. 13st.

Flower **Cast Off**

3 rows

27 sts.

1

2

Stitch

Stitch

Gather

Shape into a circle and sew round the button-hole.

Sew button here opposite button-hole.

3

Cut 12 strands of yarn

1m 80cm

divide into 3 and plait a handle.

1 2 3

2 1 3

2 3 1

Knot ends

Sew along sides

You will see at the beginning of this book that several projects are illustrated but no instructions are provided — but don't worry — have a go referring to the general guides.

Project 6

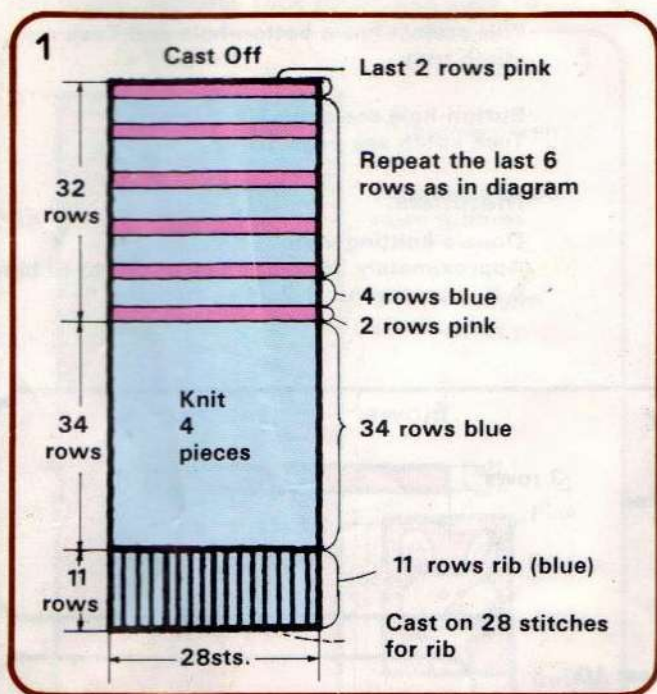

Tank Top



Materials:
 approx: Double knitting Yarn
 Blue 100gm Pink 20gm

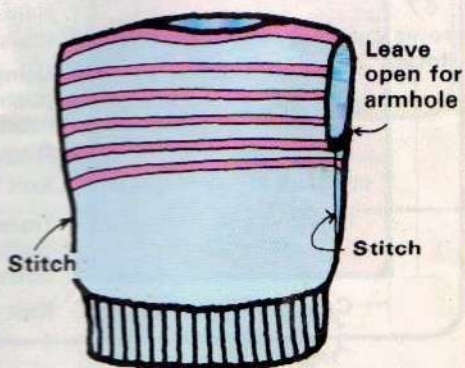
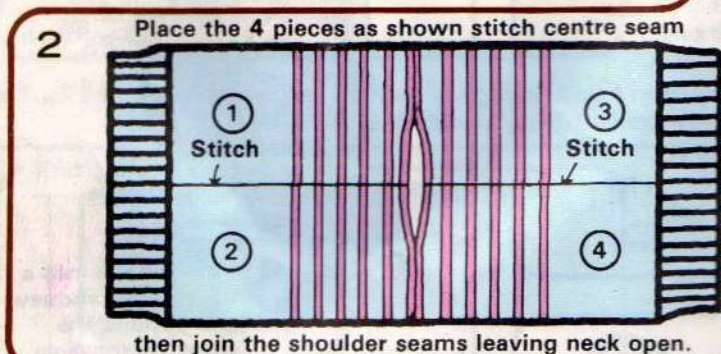

Finally

- * When you finish knitting pull your work length wise after casting off. (This helps to close the stitches.) Then leave it to relax for an hour or so before making up.
- * Experiment with changing colour when knitting tuck stitch to obtain beautiful fabrics. Try thick and thin yarn in alternate stripes.
- * Remember you can sew pieces together to make your work wider. Why not make this a design feature — knit one side of the article in one colour and one in another for example, reversing the colour on the back of the article.

TOMY®

Hobby Girl Project Centre
 Tomy UK Ltd
 Wells House, 231 High Street
 Sutton, Surrey SM1 1LD

© TOMY 1984
 PRINTED IN JAPAN