

**SPECIFICATION**  
and  
**INSTRUCTION BOOK**

*the*

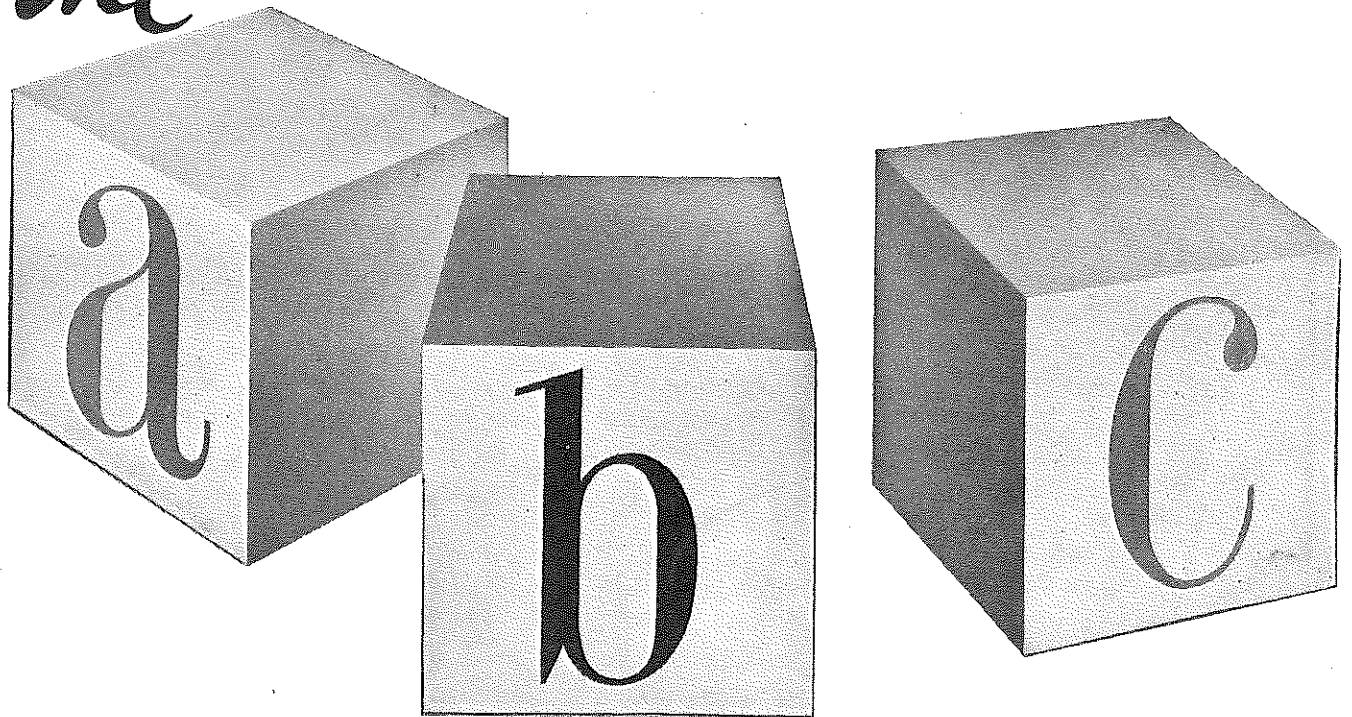

of the *Record*

**HAND KNITTER**

## FOREWORD

As you have now become the proud owner of a "Record" Machine you can thus look forward to many pleasurable hours of knitting, but before attempting to use the equipment, we strongly advise and ask you to study and proceed step by step through the detailed instructions given in this booklet.

Once you have mastered the operation of the "Record" Knitter, we advise you before beginning any piece of work to knit a sample piece, as yarns differ in quality and type, to better determine dimension and size of stitch to be utilized.

It is advisable to knit a sample piece of work, say 20 stitches wide and 20 rows. Remove this sample from the comb, lay it on the table and measure it. 20 stitches = ..... inches, 20 rows = ..... inches. Now you can easily calculate the number of stitches and rows you need for the desired garment. The sample piece should be kept until the garment is finished; the exact number of stitches to be increased or decreased for armholes, necklines, etc. can be made out according to this piece.

Various patterns are shown in the Pattern Book, but you can obtain many additional interesting effects with the use of a little imagination.

Practice makes for perfection, therefore, do exercise a little patience, do not try to "rush it", speed will come to you automatically.

# THE "RECORD" HANDKNITTING MACHINE

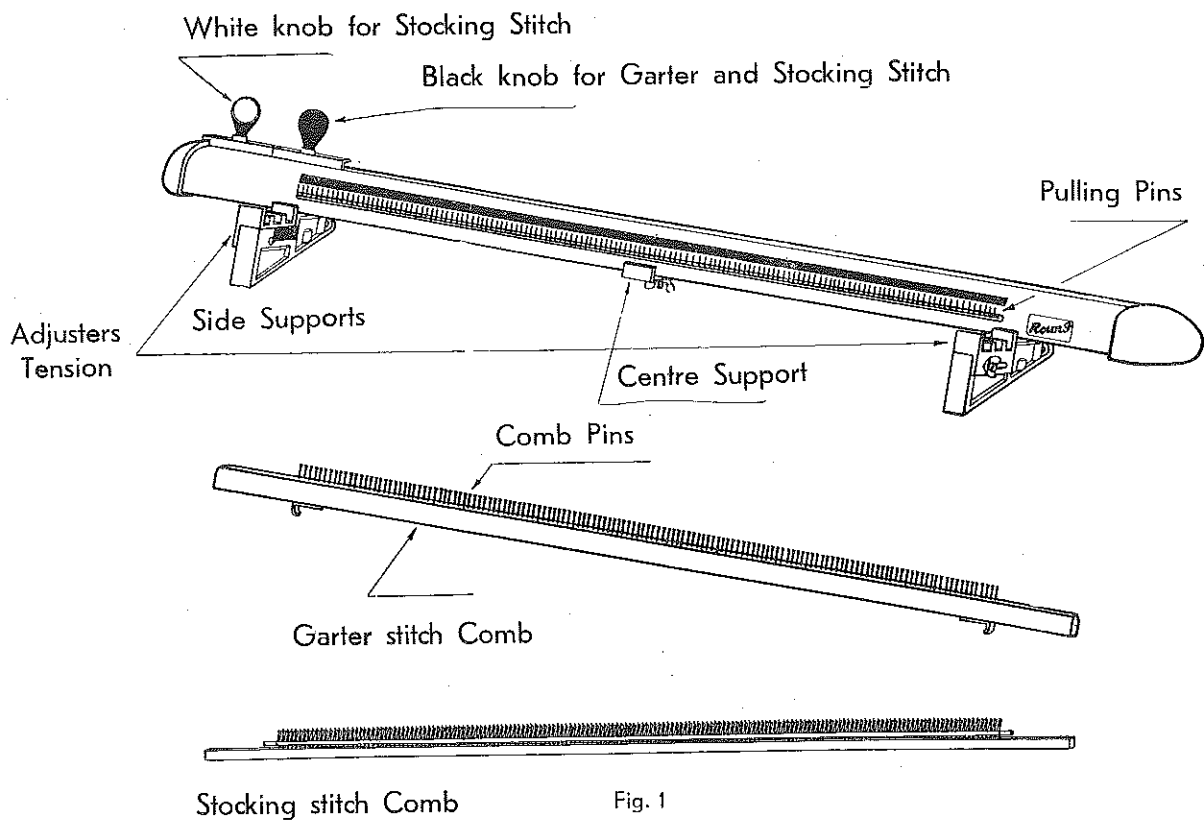

## STOCKING STITCH

- A. 1 The Metal Comb is used for Stocking Stitch.
- B. 2 The **Centre Support** on the machine must be adjusted in such a way that the comb is always firmly supported from behind, yet allowing for the knitting

to pass between the centre support and comb. This ensures a uniform formation of stitches on the whole range of the comb.

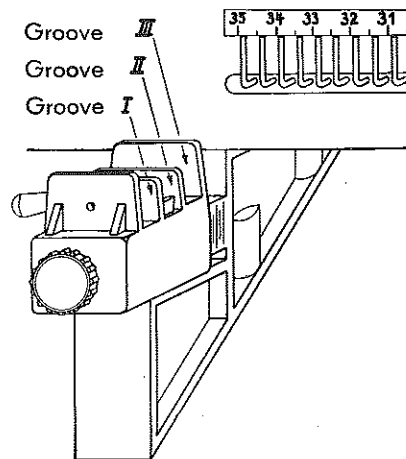

C.3 Place the metal comb into **Groove I** of the side supports so that the flap of the comb and the red dot faces the machine. Starting on the left-hand side the wool is cast on the comb pins by means of a slip knot loop. (Figs. 3 & 4.)

So that the work is in the centre of the comb when not using the full width. The wool should be wound anti-clockwise around as many comb pins as stitches are desired and pressed down with the forefinger. (Fig. 5.)

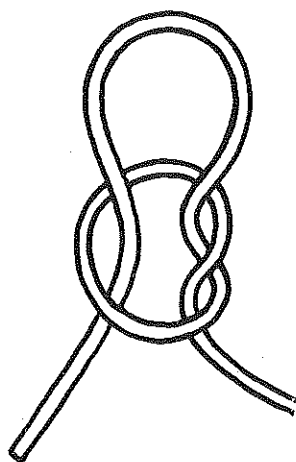

Fig. 3

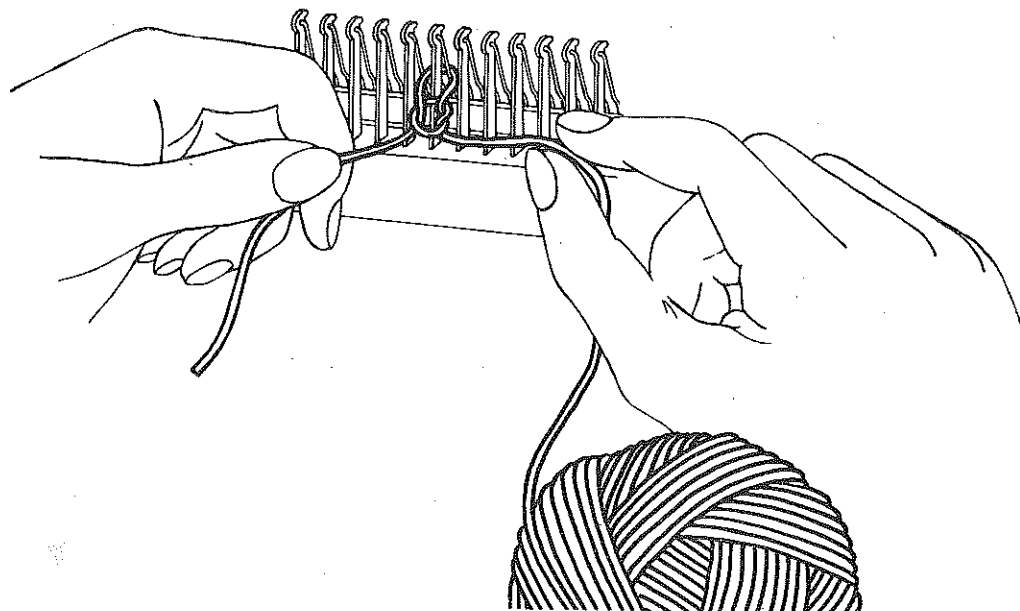

Fig. 4

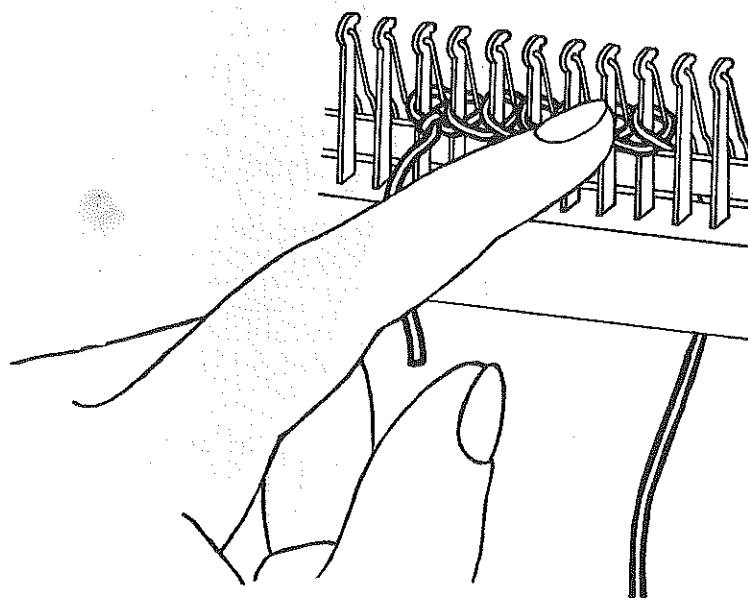

Fig. 5

D. 4 Turn the metal comb so that the flap and the red dot is facing you and the knitting is behind the comb, then place it into **Groove III**. The size of the stitches is regulated by the adjusters fitted on both side supports; of course, the density of the wool should be taken into consideration. Tighter or looser stitches are produced by regulating

the adjusters on both side supports. The closer the comb is placed to the machine the smaller the stitches, the more distant, the larger. It is important that both adjusters are set to exactly the same reading on the side supports, so that the comb when placed in **Groove III** can then be seen to be running parallel to the machine.

E. 5 Place the metal comb into **Groove III** in such a manner that the pulling pins push through between

the comb pins. (Fig. 6.)

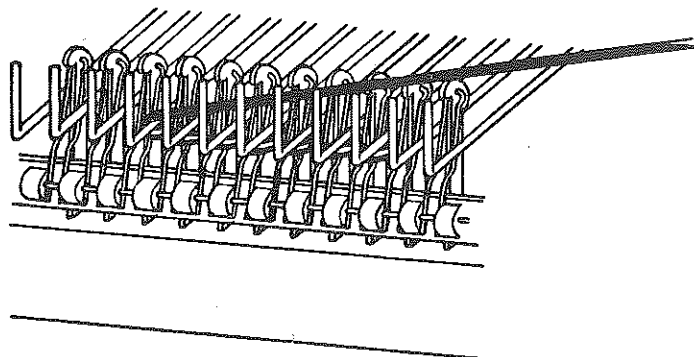

Fig. 6

F. 6 Slide the **Black Knob** to the **Extreme Right** and place the wool into the channel between the projecting pulling pins and the comb-pins a few stitches

further than the cast-on stitches. Then slide the **White Knob** to the **Extreme Right** and the wool will then be in a zig-zag position.

G. 7 The hinged flap of the comb should be lifted up and over smartly so that the row of stitches on the

comb-pins is thrown right over the projecting pins. The flap is then put back to its normal position.

H. 8 **The comb is not turned**, but **only** the right-hand side of it raised up slightly with the right hand sufficiently to lift the stitches clear off the pulling pins, the work being held firmly with the left hand and pulled downwards so that the stitches come to

rest at the base of the comb; replace comb into **Groove III**. Until sufficient rows have been knitted to get a grip of the work, it will be necessary to push the stitches down carefully with the left hand.

I. 9 If the stitches become too tight so that the comb-flap cannot be lifted up easily, use the adjusters on

the side supports and increase the size of the stitch slightly.

J. 10 Now slide the **White Knob to the left** and again place the wool into the channel as previously and

**follow up** with the **Black Knob**. This action is now repeated row after row.

K. 11 Casting-off, decreasing, increasing, making button-holes, etc. is done in exactly the same way as on

the Garter Stitch Comb. (Wooden Comb.) See Garter Stitch Instructions.

L. 12 When transferring work from the Garter Stitch comb or needles onto the Stocking Stitch comb,

always hang the work **On The Back Of The Comb**. i. e.: the comb flap and red dot faces the machine.

M. 13 Purl rows can be knitted by turning the comb as

per the Garter Stitch Instructions.

## GARTER STITCH

### On Wooden Comb.

- A. Slide the White Knob to the **Extreme Left** and leave it in that position, having done this, slide the Black Knob also to the **Extreme Left**. When knitting Garter Stitch or patterns the Black Knob only is used.

Tighter or looser stitches are produced by regulating the adjusters on both side supports. The closer the comb is placed to the machine the smaller the stitches, the more distant, the larger. It is important that both adjusters are set to exactly the same

reading on the side supports, so that the comb when placed in **Groove III** can then be seen to be running parallel to the machine.

The **Centre Support** on the machine must be adjusted in such a way that the comb is always firmly supported from behind. This ensures a uniform formation of stitches on the whole range of the comb.

- B. When casting on, place the Wooden Comb into **Groove I**. (Fig. 7.)

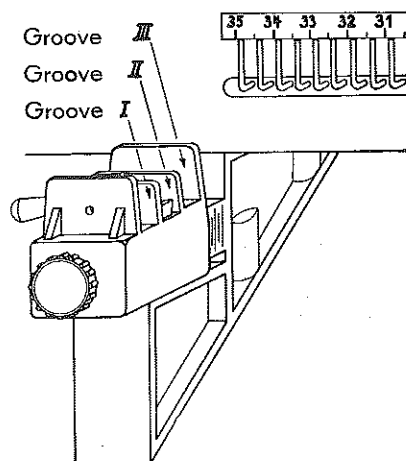

Fig 7

C. Starting on the left hand side, the wool is cast on the comb pin by means of a slip-knot loop. (Figs. 3

and 8), so that the work is in the centre of the comb when not using the full width.

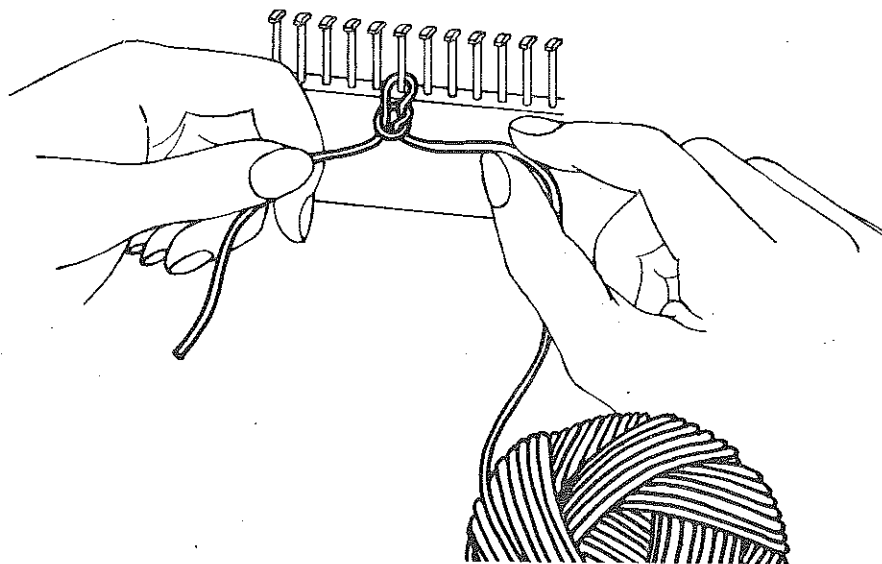

Fig. 8

Now the wool should be wound anticlockwise around as many comb pins as stitches are desired and pressed down with the forefinger. (Fig. 9.)

It should be observed that the last stitch of the required width is wound around behind the comb pin clockwise. (Fig. 10.)

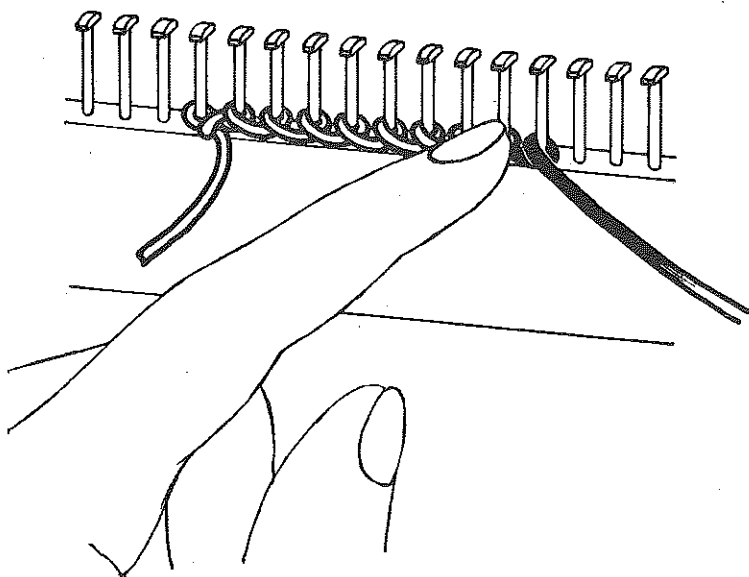

Fig. 9

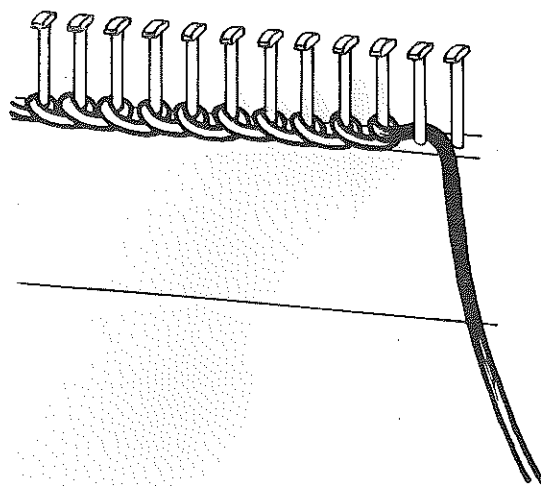

Fig. 10

D. The comb with the cast on stitches is now placed into **Groove III** see. (Fig. 2). Observe that the comb is placed correctly in the groove so that the pulling pins can push through the comb pins when operating the Black Knob.

E. Slide the Black Knob to the **Extreme Right** and starting from right to left place the wool in the channel between the projecting pulling pins and the comb pins. (Fig. 11.)

F. The wool must always be inserted a few stitches further than the width of the work. (Fig. 12.)

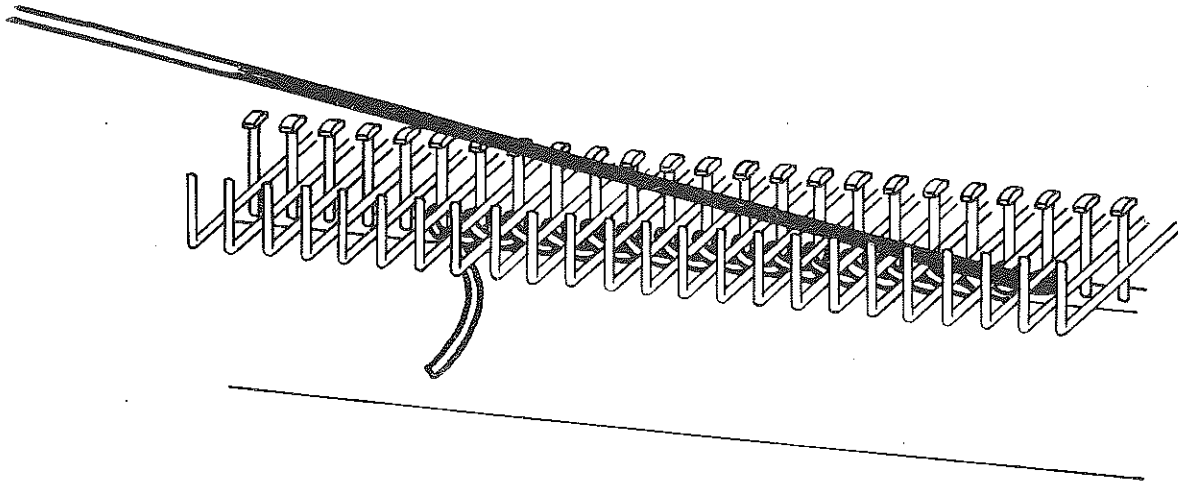

Fig. 11

G. The wool **Must Run Loosely** from the wool-ball to the machine.

H. Smoothly slide the Black Knob to the **Extreme Left** so that the wool is formed in a zig-zag position as shown. (Fig. 12.)

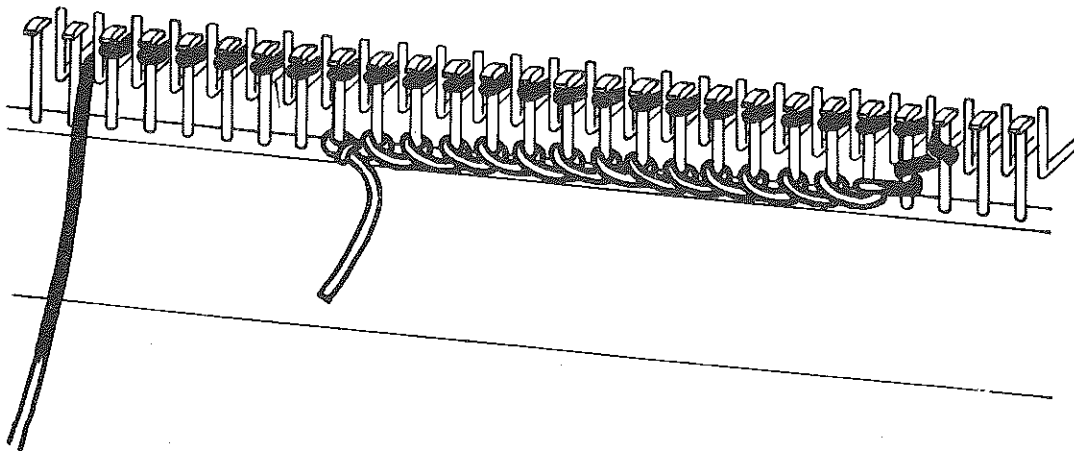

Fig. 12



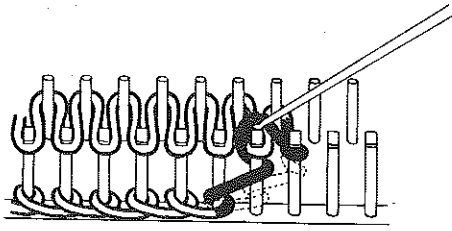

Fig. 13

I. Starting from the **Right Hand** side, the stitches on the comb-base have to be lifted over the comb-pins with the aid of the Special Hook. The first stitch is to be lifted over **One** comb-pin **Only**. (Fig. 13.) All the following stitches have to be lifted over **Two** comb-pins. (Fig. 14.) The **Last Stitch** is lifted over as shown in Figs. 15 & 15/1, observing that the slip-knot is lifted over its own pin.

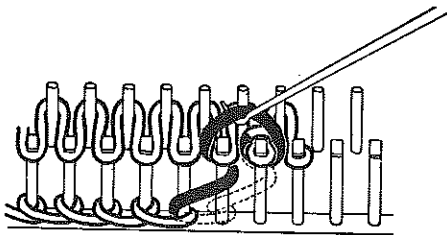

Fig. 14

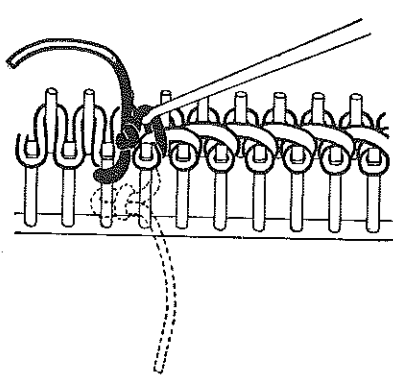

Fig. 15

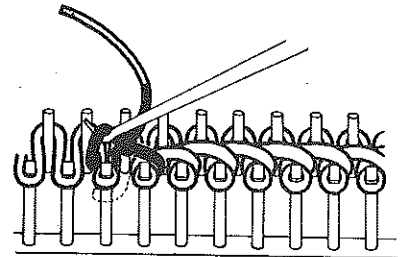

Fig. 15/1

J. **Lift Up** out of the groove the comb with the cast on wool, **Turn It Right Round**, free the surplus wool which is inserted a few stitches further than the cast on stitches and place the comb back into **Groove III** (pins upwards).

Press all the stitches right down to the base of the comb with your fingers to ensure a firm edge. (Fig. 16.)

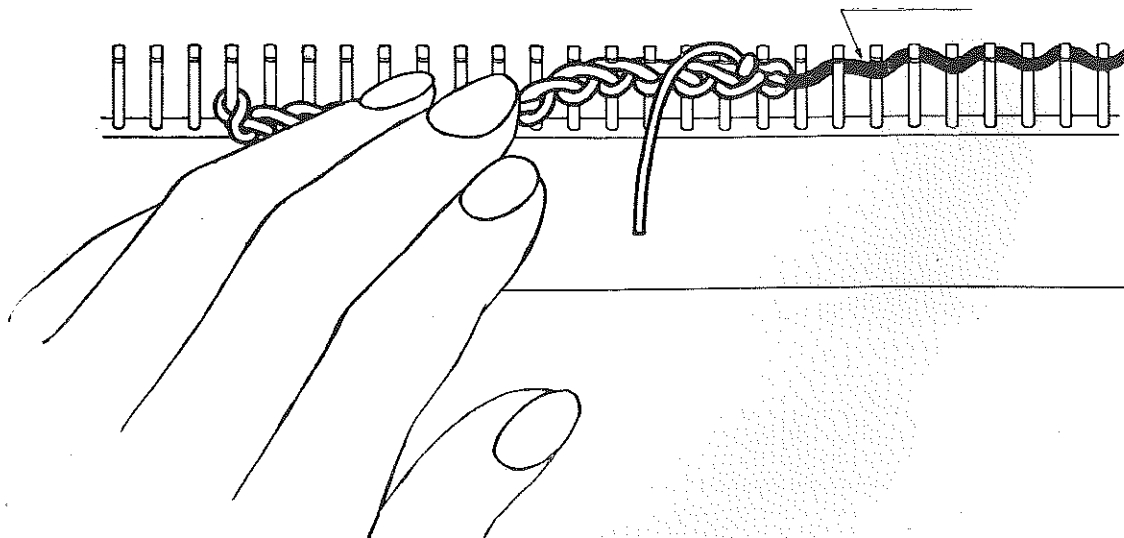

Fig. 16

K. Slide the Black Knob to the **Extreme Right**.

L. Place the wool into the channel between the projecting pulling pins and comb pins as before, see Instruction E.

M. Slide the Black Knob to the **Extreme Left**, see Instruction H.

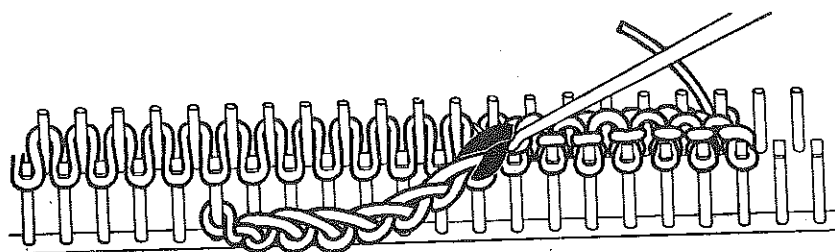

Fig. 17

N. Lift the row of stitches protruding on the base of the comb, each over **One Comb-Pin**. The first right hand stitch of every row is left untouched and **Not** lifted over. (Fig. 17.)

The first two knitted rows are lifted over with the pointed end of the special hook by inserting it **In Between** the comb pins **Under** the wool and then gently easing each stitch over the head of **Its Own** pin. (Fig. 17.)

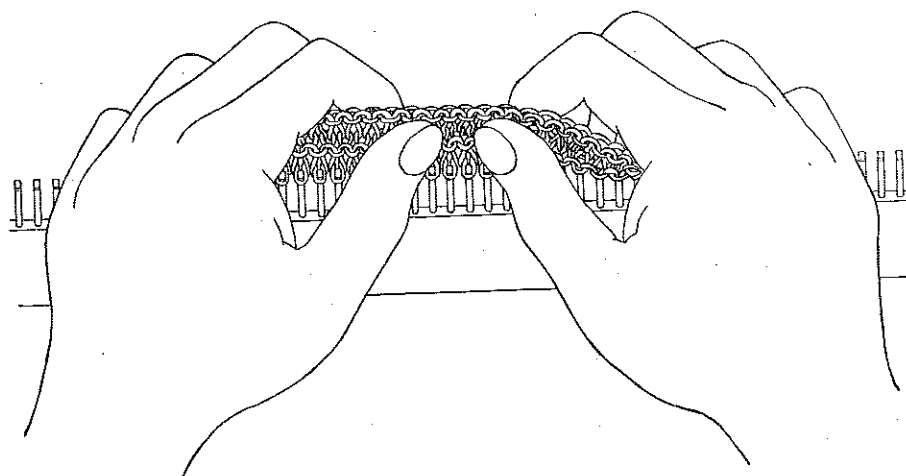

Fig. 18

O. Now the procedure is repeated starting from Para. J of the instructions.

From the third row onwards one can easily lift over

the stitches with one's fingers. (Fig. 18.) This should be a smooth action without jerking. The garment is now hanging with **Only** the last row of stitches on the comb.

P. **Decreasing** is done by crocheting the stitches on preceding comb-pins. (Fig. 19.) If decreasing one stitch only, take the last stitch and place it on the **Preceding Comb-Pin**.

Q. **Increasing** is always done in the same way as casting on. (Fig. 20.) If increasing by a single stitch, the wool must be put in from left to right around behind the comb-pin. (Fig. 21.) Increasing is always done on the **Right Hand Side Of The Work**.

R. Decreasing or increasing in the **Centre Of The Work**, remove all stitches onto a knitting needle and replace them one by one on the comb-pins, remembering to place **Two Stitches** together on one pin where the **Desired Decrease** is to be made, or in the case of **Increasing** remember to pick up an extra stitch where desired. This is usually done by picking up a stitch

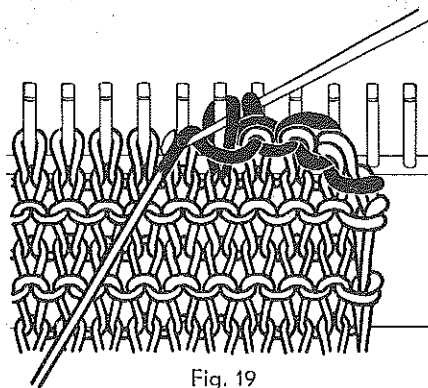

Fig. 19

from the previous row (below) and placing it on the comb-pin where an increase is desired.

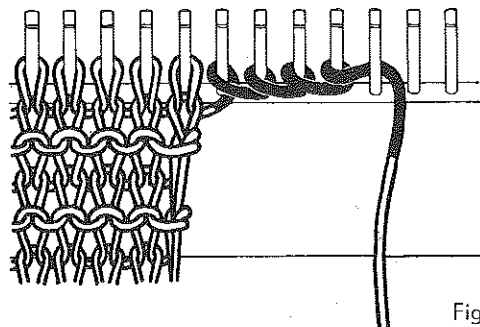

Fig. 20

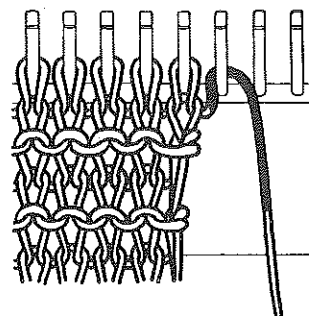

Fig. 21

S. **Dropped stitches** have to be crocheted up with a crochet hook according to pattern, and the last

stitch must be lifted over the comb-pin. (Fig. 22, 22/1 and 22/2.)

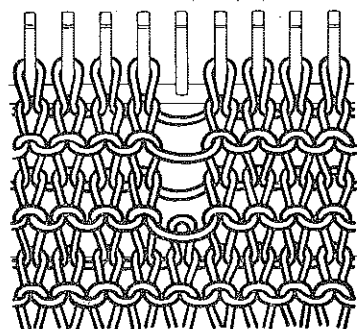

Fig. 22

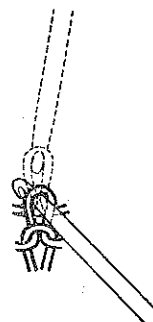

Fig. 22/1



Fig. 22/2

T. If it is necessary to undo the work, this can be done by removing the stitches from the comb-pins. To

resume work re-hang the stitches on the comb-pins so that the wool is on the **Right Hand Side**.

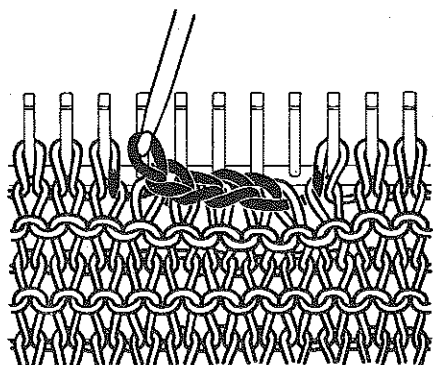

Fig. 23

U. **Button Holes** are made by crocheting off with the hook one by one the number of stitches wanted from the comb-pins. (Fig. 23.) The last stitch is hung over the comb-pin as illustrated. The comb should now be turned right round and then a row knitted over. The large loop now apparent is formed into stitches on the comb-pins. (Fig. 23/1.) Then the usual method of knitting should be followed.

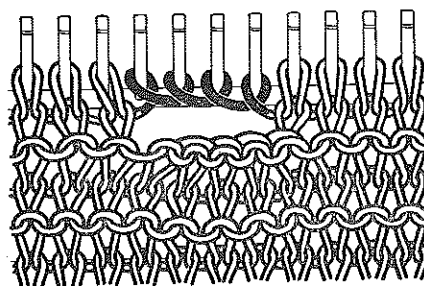

Fig. 23/1

V. **Casting-Off**, carefully remove the stitches one at a time from the comb-pins and proceed to crochet in the same manner as used when decreasing. Do not pull the yarn tightly, the border should be even and elastic.

Printed in Austria