

# **TOYOTA**

**knitting machines**

## **SERVICE MANUAL**

**MODEL KS950**

**AISIN SEIKI CO., LTD.**

## **PREFACE**

This service manual gives troubleshooting and repairing procedures. For fast and proper troubleshooting and repair, it is important to understand the mechanisms.

Some areas in the figures not related to the functions may differ from the actual components.

**CONTENTS**  
**(KS950)**

<b>I. SPECIFICATIONS</b> .....	1
I-1 Specifications of Knitting Machine .....	1
I-2 Specifications for Assembly .....	4
(1) Needle bed .....	4
(2) Needle bed and carriage .....	5
(3) Carriage .....	6
(4) Lace attachment .....	7
<b>II. EXPLANATION OF MECHANISM</b> .....	8
II-1 Needle Bed and Needle Selection Mechanism .....	8
(1) Automatic needle selection mechanism .....	8
(2) Motif magic mechanism .....	10
II-2 End Needle Selection Mechanism .....	11
II-3 Carriage .....	12
(1) Pattern dial .....	12
(2) Knitting passage .....	13
II-4 Lase Knitting Mechanism .....	14
<b>III. SPECIAL SERVICE TOOL</b> .....	17
(LIST OF SST)	
<b>IV. EXAMINATION OF TROUBLE</b> .....	19
IV-I Knitting by Carriage .....	19
(1) Movement of carriage is heavy .....	19
IV-2 Plain Knitting .....	20
(1) Stitch drops .....	20
(2) Yarn slackens at end of swatch .....	20
(3) Loop slip, double loop hook .....	21
(4) Uneven stitches .....	21
IV-3 Knitting at the time of Pattern Knitting .....	22
(1) Stitch drops at the time of tuck knitting .....	22
(2) Loop slip in weaving knitting .....	22
(3) Stitch drops at the time of fair isle knitting .....	22
(4) Cam is not operated according to pattern dial .....	22
IV-4 Knitting by Lace .....	24
(1) Stitch at Needle D is not transferred but drops .....	24
(2) Yarn gets broken while knitting .....	25
(3) Carriage stops during movement .....	25
IV-5 Knitting by Card Needle Selection .....	26
(1) Needle to be selected according to pattern of card is not selected between 24 pitches or 8 pitches .....	26
(2) Needle to be selected according to pattern of card is not selected, irrespective of 24 pitches or 8 pitches .....	27

	(3) Needle not to be selected according to pattern of card is selected at every 24 pitches or 8 pitches .....	27
	(4) Needle not to be selected according to pattern of card is selected, irrespective of 24 pitches or 8 pitches .....	28
	(5) At the time of motif magic needle selection, pattern is out of instructed position .....	28
	(6) The number of needles selected at every 24 pitches or 8 pitches is larger or smaller (This takes place only at connecting portion or punch card) .....	28
	(7) During lace needle selection, needle to be selected according to pattern of card irrespective of 24 pitches or 8 pitches, is not selected .....	28
	(8) No needle is selected at all .....	29
IV-6	End Needle Selection .....	29
	(1) During lace knitting needle at D position at the end does not move to B position .....	29
	(2) During end needle selection, carriage sliding is heavy .....	29
<b>V.</b>	<b>ADJUSTMENT OF EACH PART .....</b>	<b>30</b>
V-1	Clearance between Carriage and Needle Bed .....	30
V-2	Clearance between Fabric Presser and Sinker .....	31
V-3	Clearance between Front End of Fabric Presser and Latch Needle .....	32
V-4	Position of Latch Brush .....	33
V-5	Clearance between Yarn Feeder and Latch Needle .....	34
V-6	Crack and Burr of Yarn Feeder .....	35
V-7	Crack and Burr of Fabric Presser .....	35
V-8	Vertical Position of Weaving Brush .....	36
V-9	Assembling Position of Knitting Cam .....	37
V-10	Position of Card Drum Shaft .....	38
V-11	Position of Selection Pin Holder Plate .....	39
V-12	Position of Motif Magic Plate .....	41
V-13	Position of Spring Holder .....	42
V-14	Height of Needle Selection Base Drum .....	43
V-15	Position of Latch Guide .....	44
V-16	Crosswise Position of Needle Cam .....	45
V-17	Position of Needle Moving Cam .....	46
<b>VI.</b>	<b>REPLACEMENT OF MAIN PARTS .....</b>	<b>47</b>
VI-1	Replacement of Stitch Tension Dial and Pattern Dial .....	47
VI-2	Replacement of Carriage Handle Base Plate (Left) and Pattern Drive Pin .....	48
VI-3	Replacement of Selection Drive Rod Link and Carriage Handle Base Plate (Right) .....	49
VI-4	Replacement of Raising Cam, Knitting Cam and Variable Cam .....	50
VI-5	Replacement of Fair Isle Knitting Cam and Swing Cam .....	52
VI-6	Replacement of Tuck Cam and Tuck Cam Spring .....	54

VI-7	Replacement of Guide Cam and Valve Cam .....	55
VI-8	Replacement of Needle Press Cam and Sorting Plates 1 and 2 .....	56
VI-9	Replacement of Selection Cam .....	57
VI-10	Replacement of Lace Cam .....	58
VI-11	Replacement of End Needle Selection Cam .....	59
VI-12	Replacement of Selection Plate Holder Ass'y .....	60
VI-13	Replacement of Jacquard Base Plate .....	67
VI-14	Replacement of Needle Retaining Spring .....	71

# I. SPECIFICATIONS

## I-1 Specifications of Knitting Machine

No.	Item	Description								
1	Type	Needle operating type single needle bed knitting machine								
2	Knit stitch variation	Plain knitting, tuck knitting, slip knitting, weaving knitting, fair isle knitting, partial knitting, lace knitting (option: plaiting)								
3	Applicable yarn	Lace yarn, fine yarn (S2/20), semimedium fine yarn (S3/18), medium fine yarn (S4/18), coarse yarn (S4/10), coarsest yarn (S4/7), and other synthetic fiber equivalent to S2/20 (kind of yarn shall conform to JIS L1022.)								
4	Number of needles	200								
5	Pitch	4.5 mm								
6	Needle selection apparatus	<p>Needle selection system: Carriage automatic needle selection by punch card; needles are selected according to perforations in punch</p> <p>Needle selection timing: Rear of carriage</p> <p>Needle selection unit: Punch card: 24 needles</p> <p>Motif magic pattern apparatus: 24-needle wide one point: 1, 2, 3, 4, 5 two points: 1-2, 2-3, 3-4, 4-5 three points: 1-2-3, 2-3-4, 3-4-5 12 kinds available by dial selection system</p> <p>Card feed device:</p> <table border="0" style="margin-left: 20px;"> <tr> <td style="vertical-align: middle;">▼</td> <td style="vertical-align: middle;">Alternate row feeding position</td> <td rowspan="3" style="font-size: 3em; vertical-align: middle;">}</td> <td rowspan="3" style="vertical-align: middle;">Lever switching system</td> </tr> <tr> <td style="vertical-align: middle;">▼</td> <td style="vertical-align: middle;">Normal feeding position</td> </tr> <tr> <td style="vertical-align: middle;">■</td> <td style="vertical-align: middle;">Stopping position</td> </tr> </table> <p>End needle selector Carriage needle selection by detection of needles at A position. (1) Needle to B and needle to D selection at both ends: Automatic switching by loading and unloading the lace fabric presser (2) Switching to no operation of end needle selection: Pivoting of the slotted shaft inside the sensor cam</p>	▼	Alternate row feeding position	}	Lever switching system	▼	Normal feeding position	■	Stopping position
▼	Alternate row feeding position	}	Lever switching system							
▼	Normal feeding position									
■	Stopping position									

No.	Item	Description
7	Stitch tension adjustment	Dial switching (knitting cam adjustment)   .. 0 .. 1 ~ .. 10    33 divisions equally spaced
8	Cam switching	(1) Tuck knitting, plain knitting, fair isle knitting, slip knitting: Central control system subject to rotation of pattern dial (2) Partial knitting: Slide knob type (at left front upper surface) (3) Weaving yarn presser wheel: Lever type (at front of fabric presser) (4) Selection cam: Rotating lever type (on right rear) (5) Pattern drive pin: Rotating lever type (on right rear) (6) Cam switching: Lace selector cam (1), lace selector cam (2), lace selector cam (3), end needle selector cam: Joint-operation switching by mounting the lace attachment
9	Yarn feeder	Plain knitting yarn feeder    }    Integral type (with yarn off prevention) Pattern knitting yarn feeder    }    Interchangeable with plaiting yarn feeder Weaving knitting yarn feeder    }    External opening, fixed type
10	Fabric Presser	(1) Fabric Presser: (2) Lace attachment: Installed for lace knitting only (left, right)
11	Carriage handle	Pick-up and bring down type Locked at standing position
12	Accessory box	• Integral with pattern board • Detachable lid with a scale graduated in mm • Fixed on the knitting machine needle bed
13	Take-up rod	Double yarn take-up (with extra spring) Installed at two positions; centre and left end
14	Standard weight	12.7 kg    Machine    8.8 kg Carriage    2.2 kg Accessories 1.7 kg (except instruction book)
15	Case size	98.2 (H) × 192.5 (W) × 1,058 (L) mm

No.	Item	Description
16	Normal speed	50 – 70 cm/sec
17	Knit tracer	Detachable at rear part of main knitting machine (option)
18	Set of rib knitting machine	KR506, immediately assembled type (option)
19	Other	With carriage drop prevention brake



## I-2 Specifications for Assembly

## (1) Needle bed

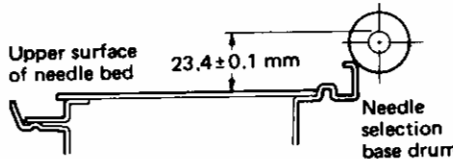
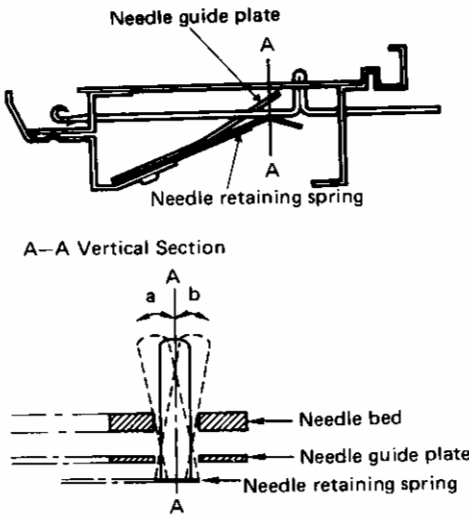
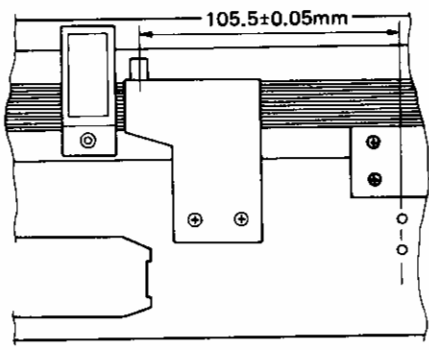
No.	Item	Measuring Condition and Method	Standard Value
1	Height of needle selection base drum	From upper surface of needle bed to upper surface of needle selection base drum  	23.4±0.1 mm
2	Positions of needle guide plate and needle retaining spring	 <p>A-A Vertical Section</p> <p>Position of needle retaining spring } To be at centre position of needle groove of needle bed</p> <p>Position of groove of needle guide plate } To be at centre position of needle groove of needle bed</p> <p>* Lean of the latch needle should be equal in both sides, a and b.</p>	
3	Position of selection pin stopper		105.5±0.05mm

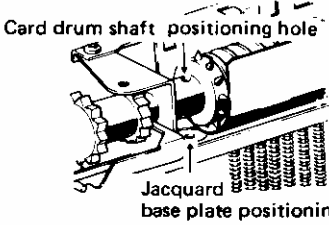
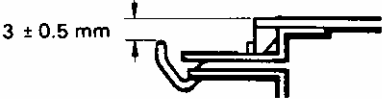
No.	Item	Measuring Condition and Method	Standard Value
4	Position of card drum shaft	Card drum shaft positioning hole should be properly aligned with Jacquard base plate positioning hole.  	
5	Height of sinker	From upper surface of needle bed to end of sinker  	$3 \pm 0.5 \text{ mm}$

(2) Needle bed and carriage

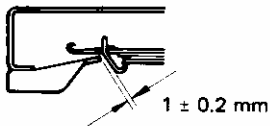
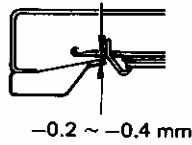
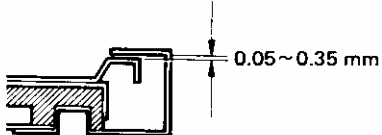
No.	Item	Measuring Condition and Method	Standard Value
1	Clearance between fabric presser and sinker	Clearance between front end of fabric presser and sinker  	$1 \pm 0.2 \text{ mm}$
2	Clearance between fabric presser and latch needle	Clearance between fabric presser and lower surface of latch needle  	$-0.2 \sim -0.4 \text{ mm}$
3	Clearance between carriage and needle bed	Clearance in vertical direction  	$0.05 \sim 0.35 \text{ mm}$

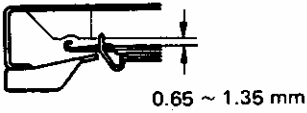
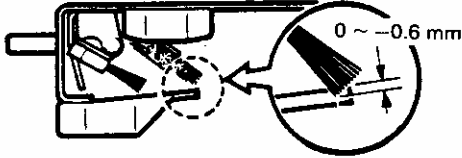
No.	Item	Measuring Condition and Method	Standard Value
4	Clearance between lower surface of yarn feeder and upper surface of latch needle		0.65 ~ 1.35 mm
5	Dimension between weaving brush and front end of fabric presser	Dimension in vertical direction 	0 ~ -0.6 mm

(3) Carriage

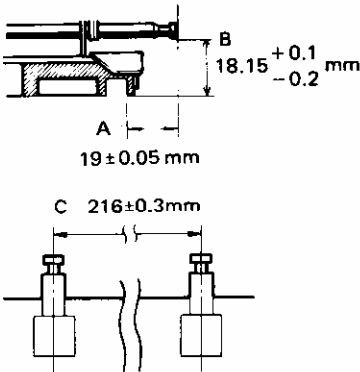
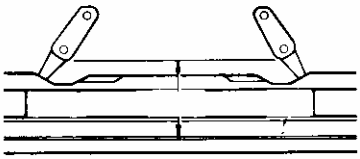
No.	Item	Measuring Condition and Method	Standard Value
1	Position of pattern drive pin	From datum surface of rear foot to operating position of pattern drive pin 	A: $19 \pm 0.05$ mm B: $18.15^{+0.1}_{-0.2}$ mm C: $216 \pm 0.3$ mm
2	Position of knitting cam in crosswise direction	From datum surface of rear foot to position of lower surface of knitting cam (in case of G-5) 	$32.6 \pm 0.1$ mm (in case of G5)  Difference in longitudinal dimension $\pm 0.05$ mm

(4) Lace attachment

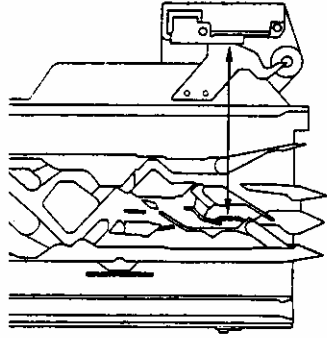
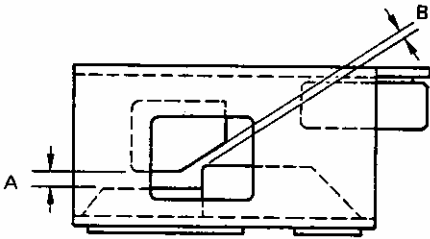
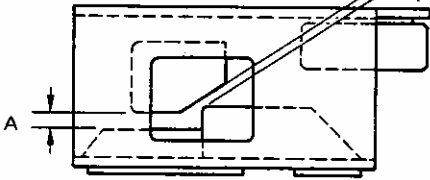
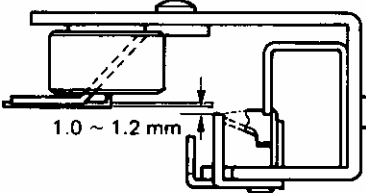
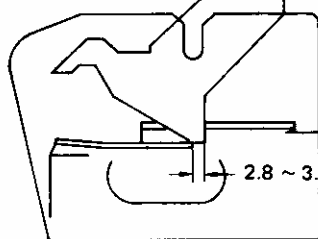
No.	Item	Measuring Condition and Method	Standard Value
1	Needle cam longitudinal position	Lace cam reference surface and needle cam dimension 	$81.4 \pm 0.2 \text{ mm}$  *Tolerance in parallel: 0.1 mm
2	Needle moving cam height	A: Needle cam (lower) reference dimension 	A 3.4 ~ 3.6 mm *Tolerance in parallel: 0.1 mm
3	Position of needle moving cam in crosswise direction	  B: Needle cam (higher) reference dimension	B 0.83 ~ 0.90 mm
4	Latch guide height	Needle cam (higher) reference dimension 	1.0 ~ 1.2 mm
5	Position of latch guide in crosswise direction	Needle cam (higher) reference dimension 	2.8 ~ 3.0 mm

## II. EXPLANATION OF MECHANISM

### II-1 Needle Bed and Needle Selection Mechanism

#### (1) Automatic needle selection mechanism

The following system chart and operation diagrams show the transmission sequence of automatic needle selection, starting from the movement of the carriage.

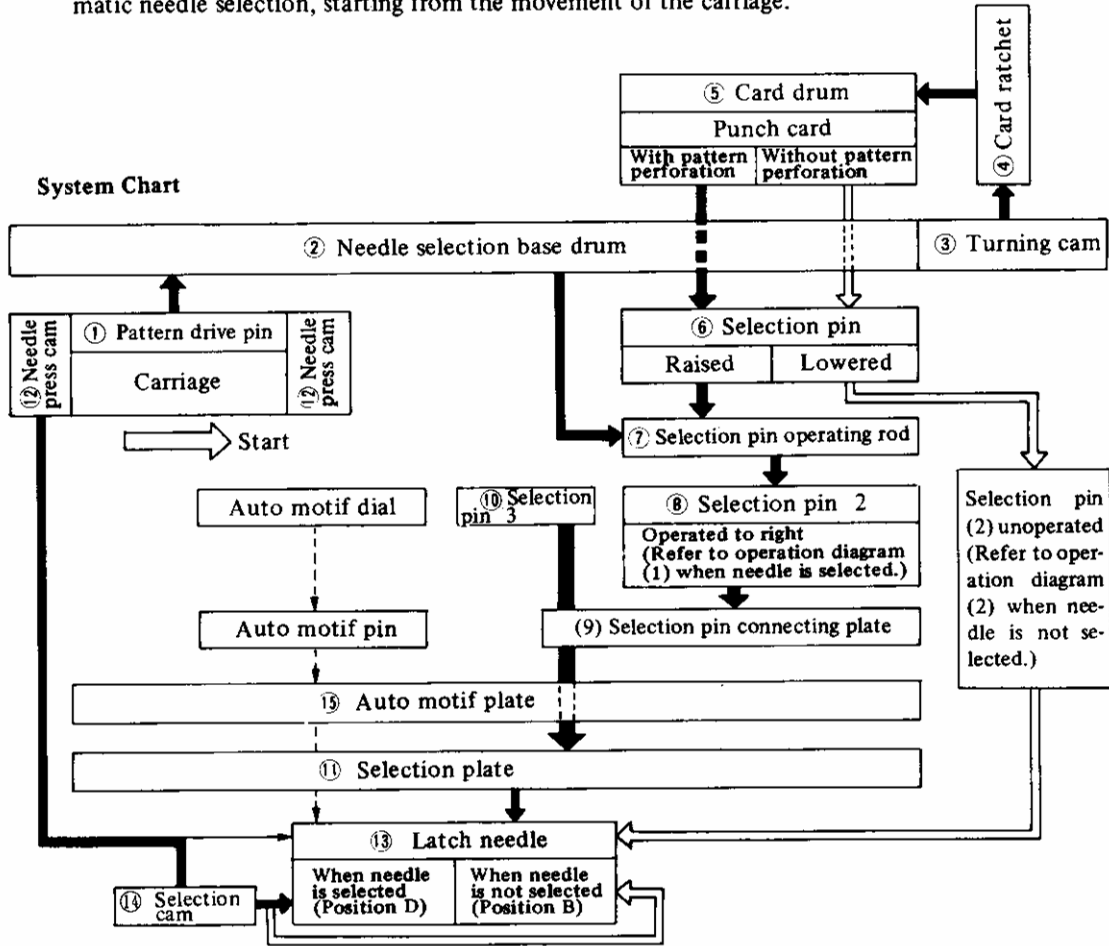

#### Cross Sectional View of System

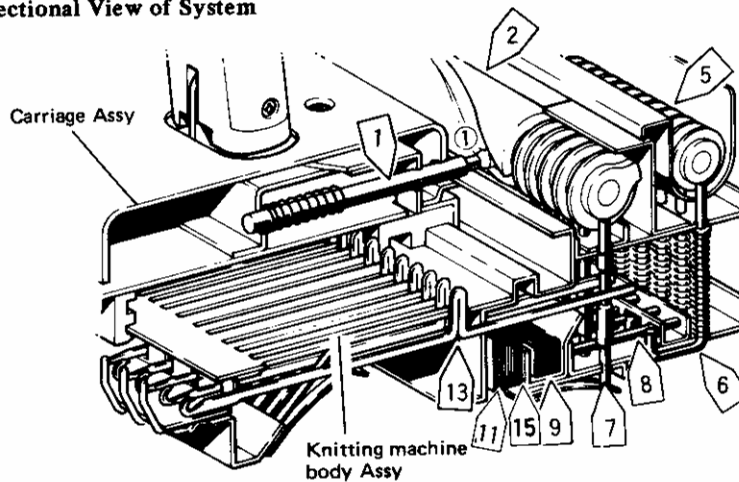
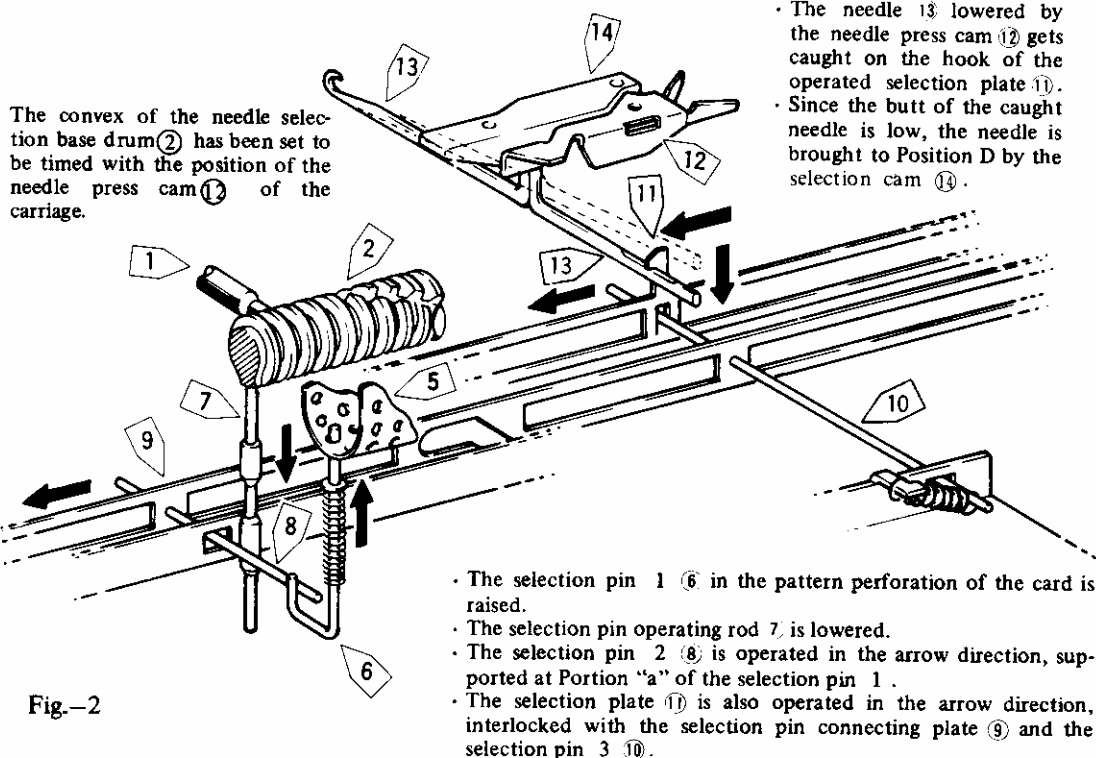
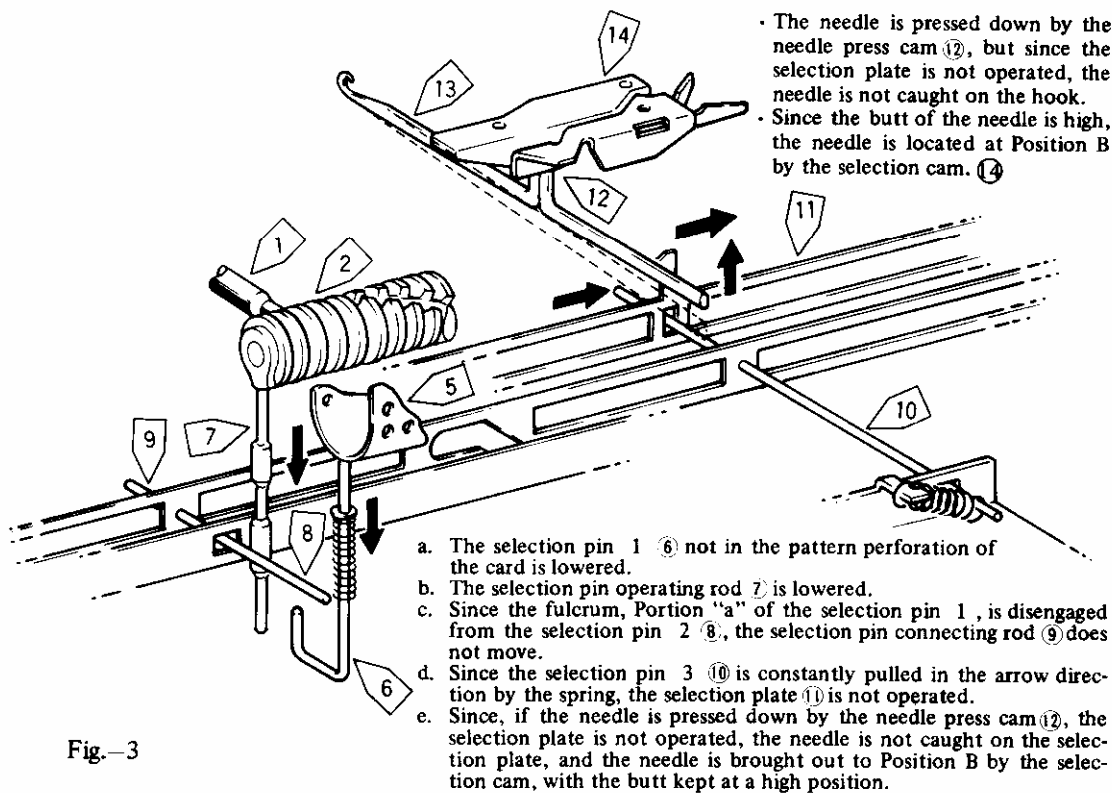

Fig.-1

(1-1) When needle is selected;



(1-2) When needle is not selected;



(2) Motif magic mechanism

(2-1) When motif magic is not performed

- When the auto motif dial is set to "0", the latch needle is located at the centre of the concave of the auto motif plate (15), and the needle pressed down by the needle press cam of the carriage is brought to the state illustrated in Fig.-4, and gets caught on the selection plate.

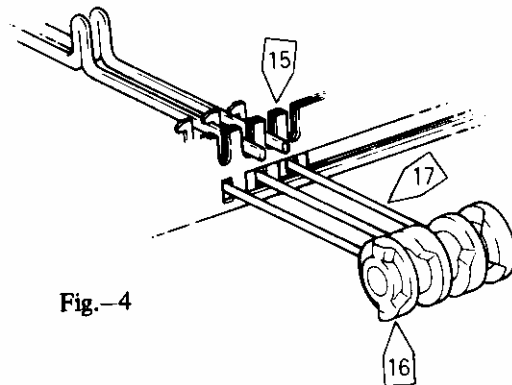

Fig.-4

(2-2) When motif magic is performed

- When the auto motif dial is rotated, the convex of the cam groove moves the dial shaft (17) in contact with the motif magic cam (16) in direction "a" indicated by the arrow.

The auto motif plate, interlocked with the auto motif pin which moved in direction "a", moves in direction "b" indicated by the arrow, and the convex comes right under the latch needle. Therefore, since the needle pressed down by the needle press cam of the carriage is supported as illustrated in Fig.-5, the needle is not lowered, and is not caught on the selection plate.

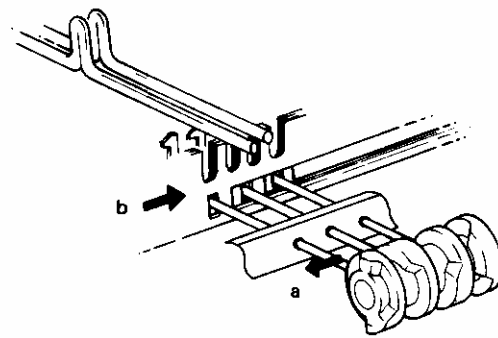

Fig.-5

(3) Position of auto motif dial and operation of auto motif plate

Position of dial	Operated auto motif plate
1	No.1 & No.3
2	No.2 & No.4
3	No.3 & No.5
4	No.1 & No.4
5	No.2 & No.5
1. 2	No.2 & No.3

Position of dial	Operated auto motif plate
2. 3	No.3 & No.4
3. 4	No.4 & No.5
4. 5	No.1 & No.5
1. 2. 3	No.3
2. 3. 4	No.4
3. 4. 5	No.5

## II-2 End Needle Selection Mechanism

In the end needle selection mechanism, needle at A position in the needle bed is detected by the sensor cam (18) in the carriage and the end needle of the working needles is forced to move to the end needle selection passage.

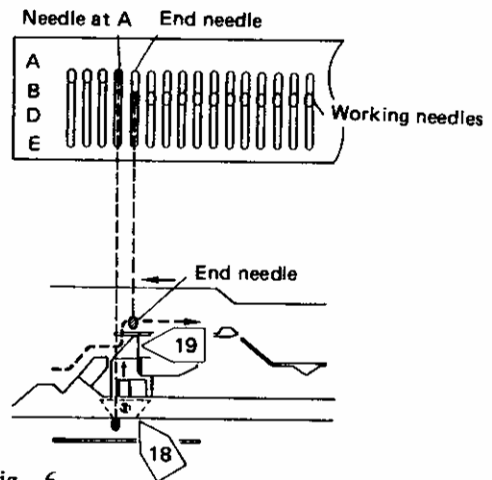

Fig.-6

### End needle selection

- (1) When the carriage moves to the knitting end, needle at A position causes the sensor cam (18) to operate, push up the end needle selection cam (19), and move the end needle to the other passage. (Fig.-6.)

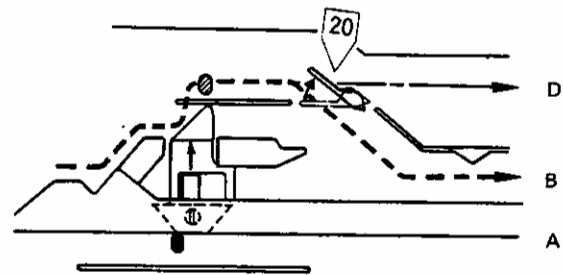

Fig.-7

- (2) When the lace attachment is installed to the carriage, the end needle selector cam (20) moves in the arrow direction and forces the end needle to move to B position, and forces the end needle to move to B position.

When the lace attachment is removed from the carriage, the end needle selector cam returns to its original position (indicated by dots) and the end needle moves to D position. (Fig.-7)

- (3) To use the end needle selection, set the sensor cam operating pin (21) as shown in Fig.-8.

When not using the end needle selection, set the sensor cam operating pin (21) as shown in Fig.-9.

- For thick yarn using every other needle.
- For fair isle motif magic.



Fig.-8

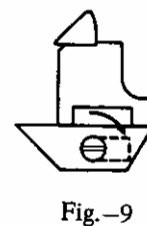

Fig.-9



**II-3 Carriage**

**(1) Pattern dial**

When the pattern dial (22) is rotated, the dial cams A, B, C and D work as described below.

(1-1) Portion A: Operates the raising cam, right (24) by way of the raising cam change lever, right (23). (Fig.-11)

(1-2) Portion B: Operates the raising cam, left (26) by way of the raising cam change lever, left (25). (Fig.-11, Fig.-12)

(1-3) Portion C: Operates the tuck cam, right (28) and the tuck cam, left (29) by way of the tuck cam plate (27). (Fig.-11)

(1-4) Portion D: Operates the fair isle knitting cam, right (32) and the fair isle knitting cam, left (33) by way of the fair isle knitting cam link, right (30) and the fair isle knitting cam link, left (31). (Fig.-13)

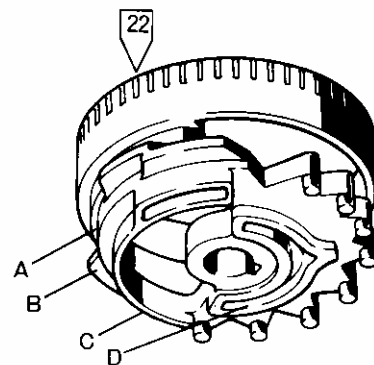

Fig-10

**a. Operation at the time of tuck knitting (A, B, C)**

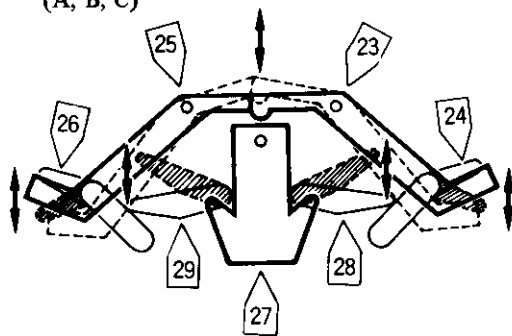

Fig.-11

**b. Operation at the time of slip knitting (A, B)**

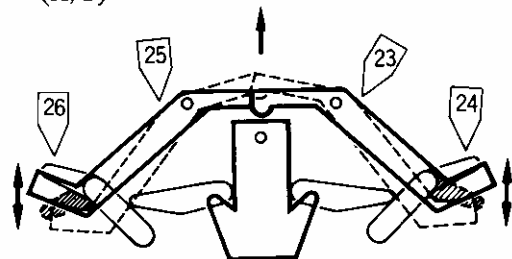

Fig.-12

**c. Operation at the time of fair isle knitting (D) and operation at the time of partial knitting (E)**

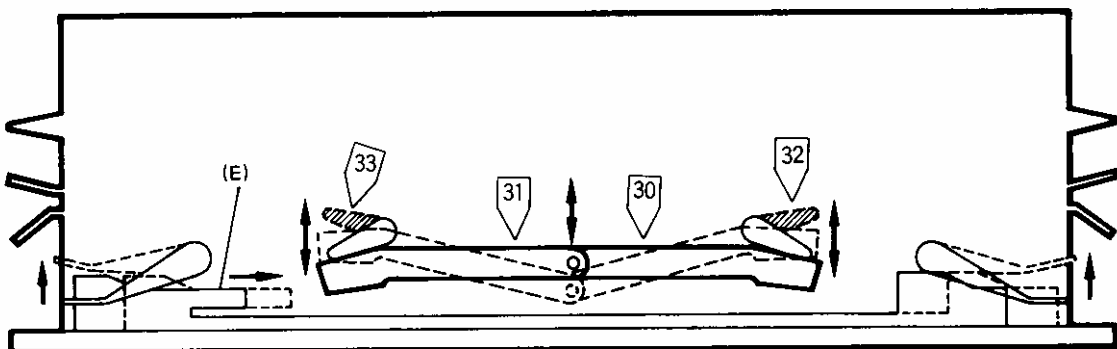

Fig.-13

(2) Knitting passage

The dotted line indicates the passage through which the butt of the latch needle passes when the carriage is moved from right to left.

(1) Plain knitting

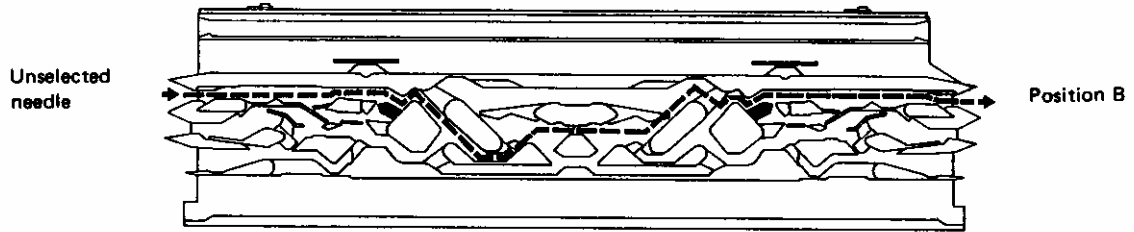

Fig.-14

(2) Fair isle knitting

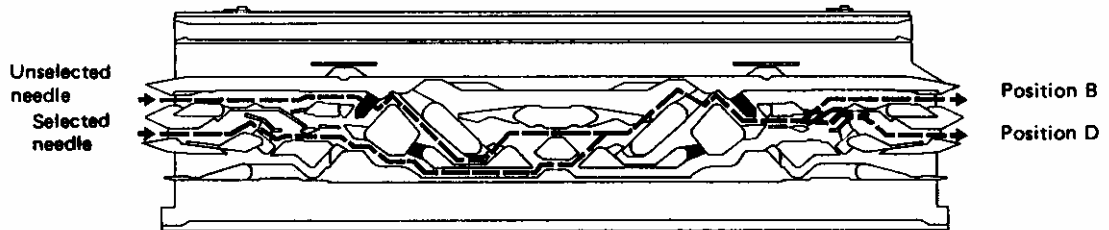

Fig.-15

(3) Tuck knitting

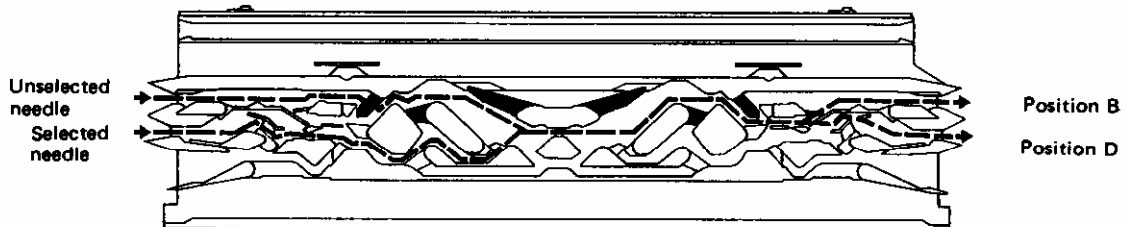

Fig.-16

(4) Slip knitting

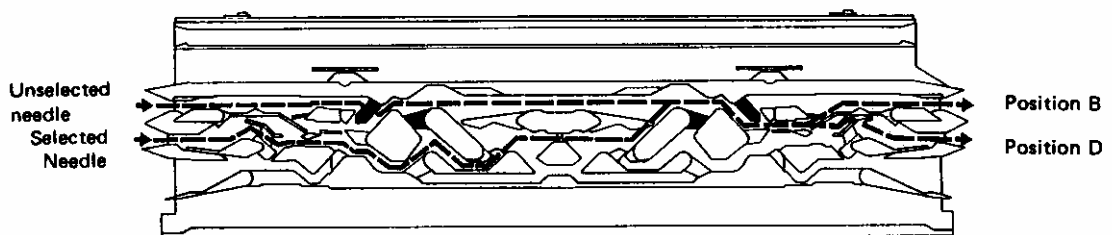

Fig.-17

#### II-4 Lace knitting Mechanism

In the lace knitting mechanism, the needle at D position is pushed to the front by the lace cams on the right and left of the carriage and moved to the needle at B position at the advancing direction of carriage movement by the higher needle cam (37) and needle moving cam (38), thus transferring the stitch and allowing lace knitting.

##### Lace knitting needle passage

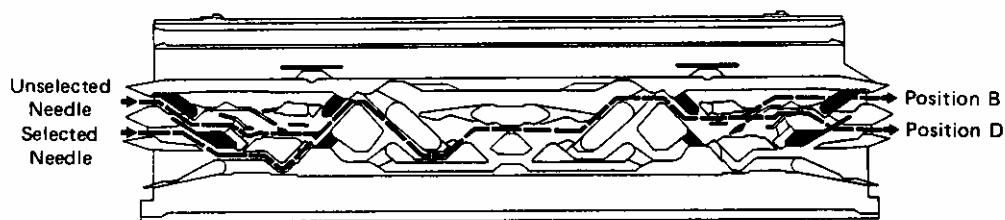

Fig.-18

##### Stitching transferring operation

- (1) When needle of D position is guided to the lace cam passage, the latch is attracted to the magnet (34), supported by the latch guide plate (35) to prevent the stitch from coming off the latch, pushed up to above the sinker (36) by the higher needle cam (37), and at the same time, pushed to the front. (Fig.-19)

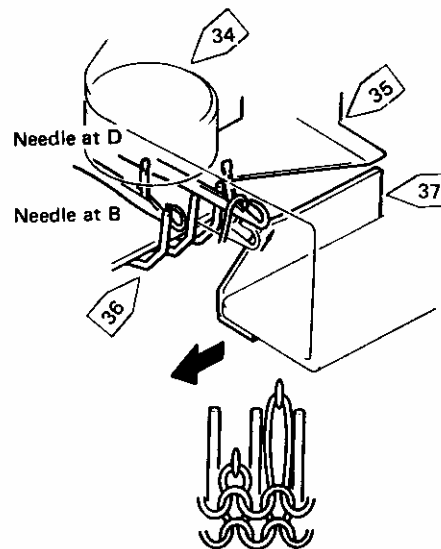

Fig.-19

- (2) When the carriage moves further forward, needle at D position comes into contact with the needle moving cam (38), climbs over the sinker (36), and is moved near to needle at B position (needle pushed up by the lower needle cam (39) in the carriage advancing direction. (Fig.-20)

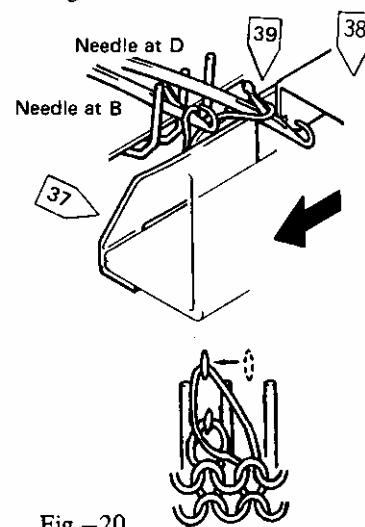

Fig.-20

- (3) Needle at D position is then disengaged from the higher needle cam (37) and intersects the hook of needle at B position.

Needle at B position is slightly pushed to the front by the lace cam and thrustured into the stitch of needle at D position. (Fig.-21)

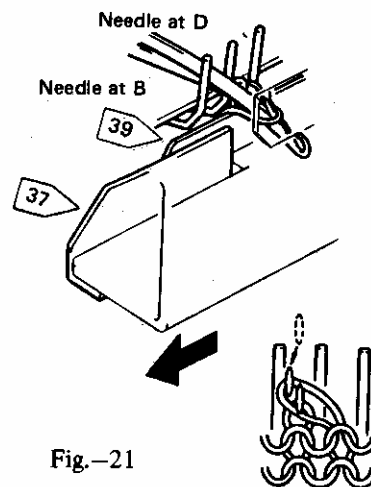

Fig.-21

- (4) As the carriage moves forward, needle at B position with two stitches starts to go down the lower needle cam (39).

At this time, needle at D position is pushed forward by the lace cam, moves the stitch completely over the latch, and is pushed up again to above the sinker by the needle reset plate (40). Crossed needles are separated. (Fig.-22)

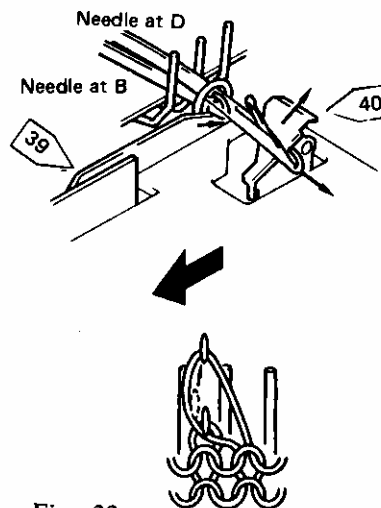

Fig.-22

- (5) Upon passing the needle reset plate (40), needle at D position climbs over the sinker and returns down. (Fig.-23)

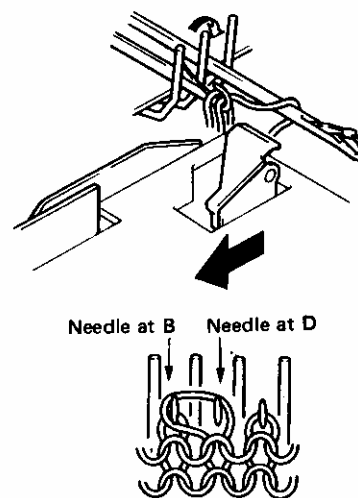

Fig.-23

- (6) Since needle at D position is pulled back by the lace cam earlier than needle at B position the stitch at needle at D position is disengaged and transferred to needle at B position.

Both needles D and B are further pulled back through the lace cam passage and enter the plain knitting passage. When the plain knitting is made one row, a lace is knit. (Fig.-24)

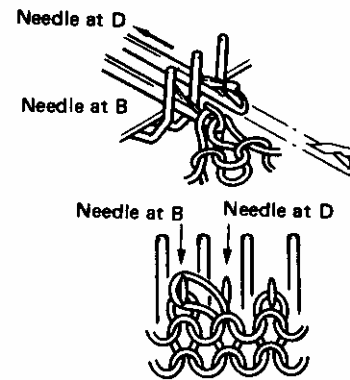
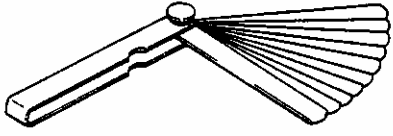
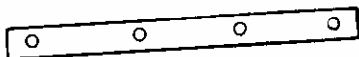
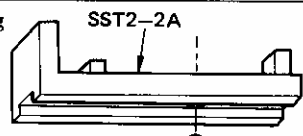

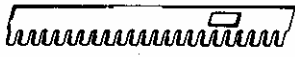

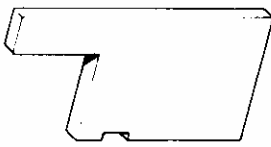
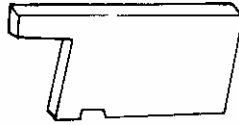



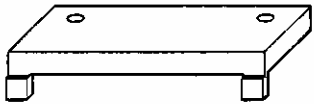

Fig.-24

**III. SPECIAL SERVICE TOOL (LIST OF SST)**

SST No.	Tool name and Schematic diagram	Model	
		950	901
SST1-1	Thickness gauge Min. 0.1 mm Max. 5.5 mm 	○	○
SST2-1	Pattern drive pin positioning tool 	○	○
SST2-2A, B	A: Pattern drive pin positioning tool 	○	○
	B: Needle cam positioning tool 	○	-
SST3	Selection pin (2) setting tool 	○	○
SST4	Motif magic and selection plate positioning tool 	○	○
SST5	Needle selection base drum positioning tool 	○	○
SST5-1	Jacquard base plate positioning tool 	○	○
SST6	Card drum shaft positioning tool 	○	○

SST No.	Tool name and Schematic diaram	Model	
		950	901
SST7	Selection pin stopper positioning tool 	<input type="checkbox"/>	<input type="checkbox"/>
SST8	Spring holder positioning tool 	<input type="checkbox"/>	<input type="checkbox"/>
SST12	Needle retaining spring setting tool 	<input type="checkbox"/>	<input type="checkbox"/>
SST22	Knitting cam positioning tool 	<input type="checkbox"/>	<input type="checkbox"/>

## IV. EXAMINATION OF TROUBLE

### IV-1 Knitting by Carriage

- When failure occurs, check and adjust in the sequence indicated by the arrows.

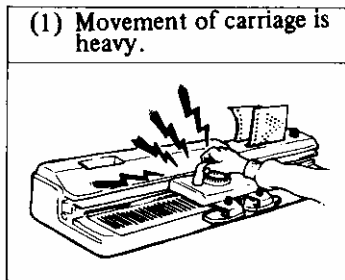

Before adjustment

- Check if there is any shortage of oil in each sliding portion.
- Check if the stitch tension dial is set smaller compared with the thickness of yarn.
- Check if the yarn adjusting dial of the upper tension is set larger compared with the thickness of yarn.
- Check if the butt, the stem or the shank of the latch needle is bent.
- Check if yarn is winding around the rubber wheel of the fabric presser.
- Check if the tension guide is tangled with yarn.
- Check if the fabric presser is inserted in the positioning hole.
- Check if the ball of yarn is wound too tight.

Carriage

Item for Adjustment	Section	Page
• Clearance between carriage and needle bed	V-1	30
• Clearance between fabric presser and sinker	V-2	31
• Crack on needle butt sliding surface of guide cam → Replace		
• Assembling position of pattern drive pin	VI-2 VI-3	48 49

Needle bed

• Crack and collapse on needle bed groove		
• Failure of rotation of needle selection base drum	V-14	43
• Improper alignment of needle guide plate and needle bed	VI-14	71



IV-2 Plain Knitting

(1) Stitch drops. (Carriage)

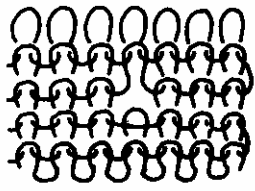

Before adjustment

- Check if position of pattern dial is set properly to position of pattern.
- Check if yarn feeder is threaded properly with yarn and if yarn feeder is closed.
- Check if stitch tension dial is set properly to yarn.

Carriage

Item for Adjustment	Section	Page
• Clearance between height of front end of fabric presser and sinker	V-2	31
	V-3	32
• Height of latch brush	V-4	33
• Clearance between yarn feeder and latch needle	V-5	34

(2) Yarn slacks at end of swatch

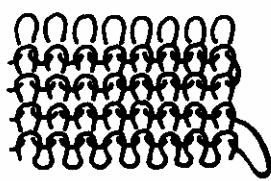

Before adjustment

- Check if movement of carriage is too fast at end portion.
- Check if yarn adjusting dial of upper tension is set smaller compared with thickness of yarn.
- Check if knot of yarn is too large.
- Check if sub-tension is used for fair isle knitting, weaving knitting, lace knitting, and motif magic

Carriage

• Crack on yarn feeder hole, and crack and burr on periphery of yarn feeder	V-6	35
• Crack and burr on front end of fabric presser → Repair.	V-7	35

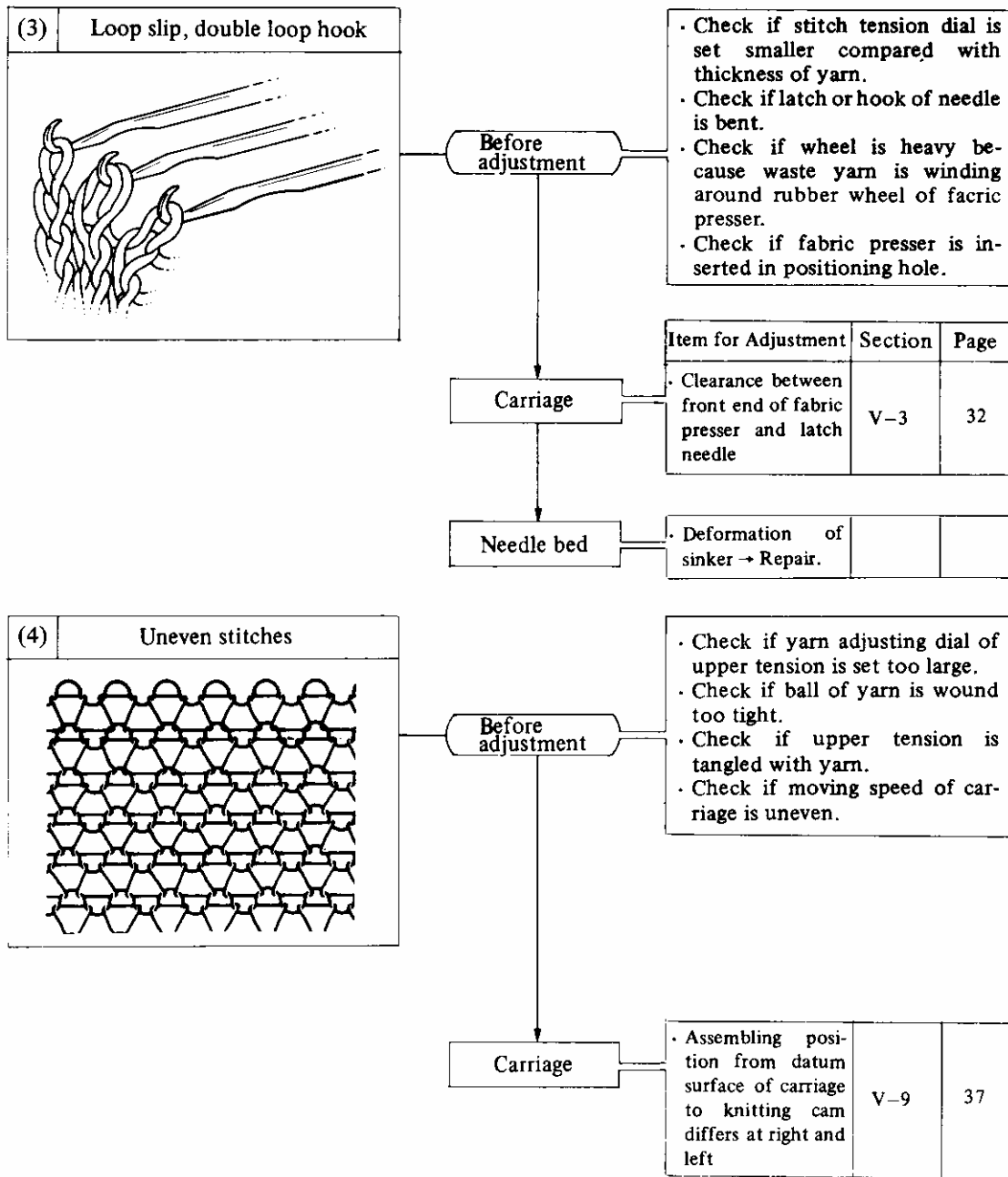

IV-3 Knitting at the time of Pattern Knitting

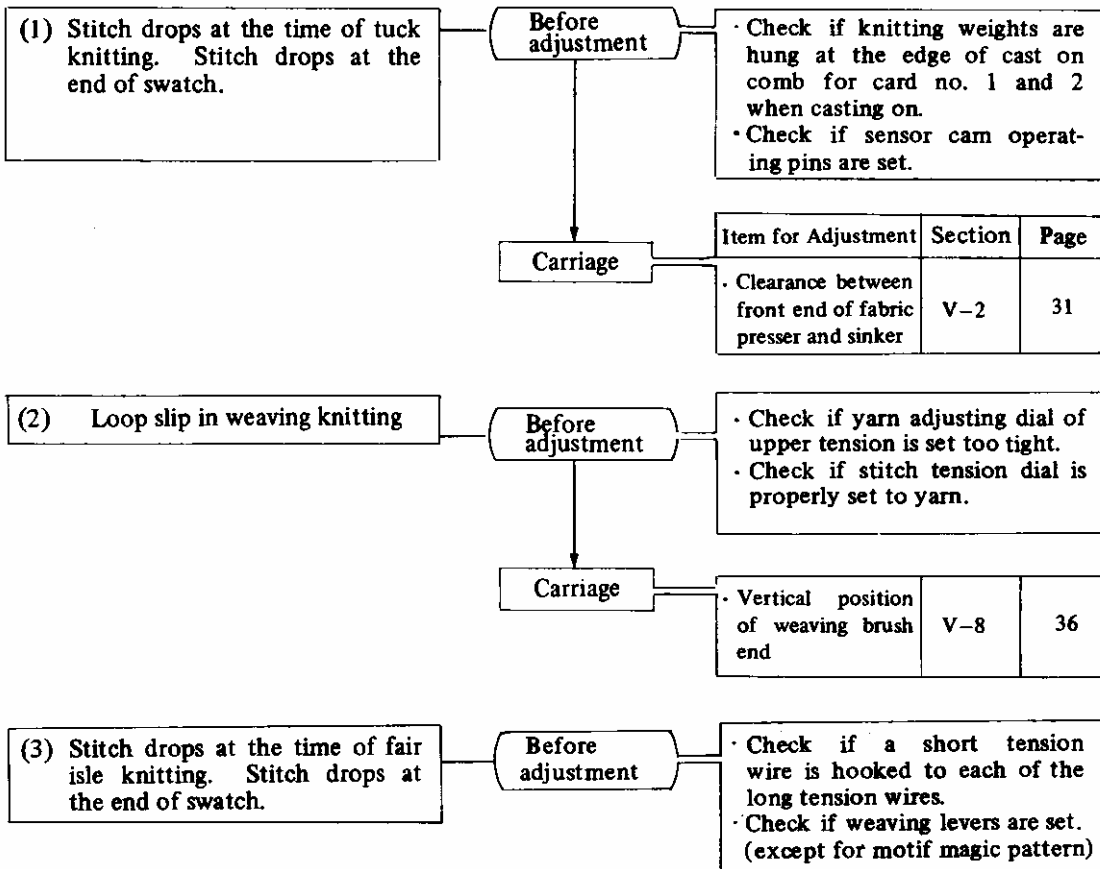

(4) When turning pattern dial cam is not operated according to pattern

Carriage

Item for Adjustment	Section	Page
· Disengagement of fair isle knitting cam spring → Repair.	VI-5	52
· Disengagement of fair isle knitting cam plate spring → Repair.		
· Wear of fair isle knitting cam → Replace.	VI-5	52
· Disengagement of variable cam spring → Repair.		

At the time of plain knitting to fair isle knitting and in reverse order

At the time of plain knitting to tuck knitting and in reverse order

Item for Adjustment	Section	Page
· Disengagement of tuck cam spring → Repair.	VI-6	54
· Breakage of tuck cam → Replace.		
· Disengagement of raising cam change lever spring → Repair.		
· Disengagement of raising cam spring → Repair.		

IV-4 Knitting by Lace

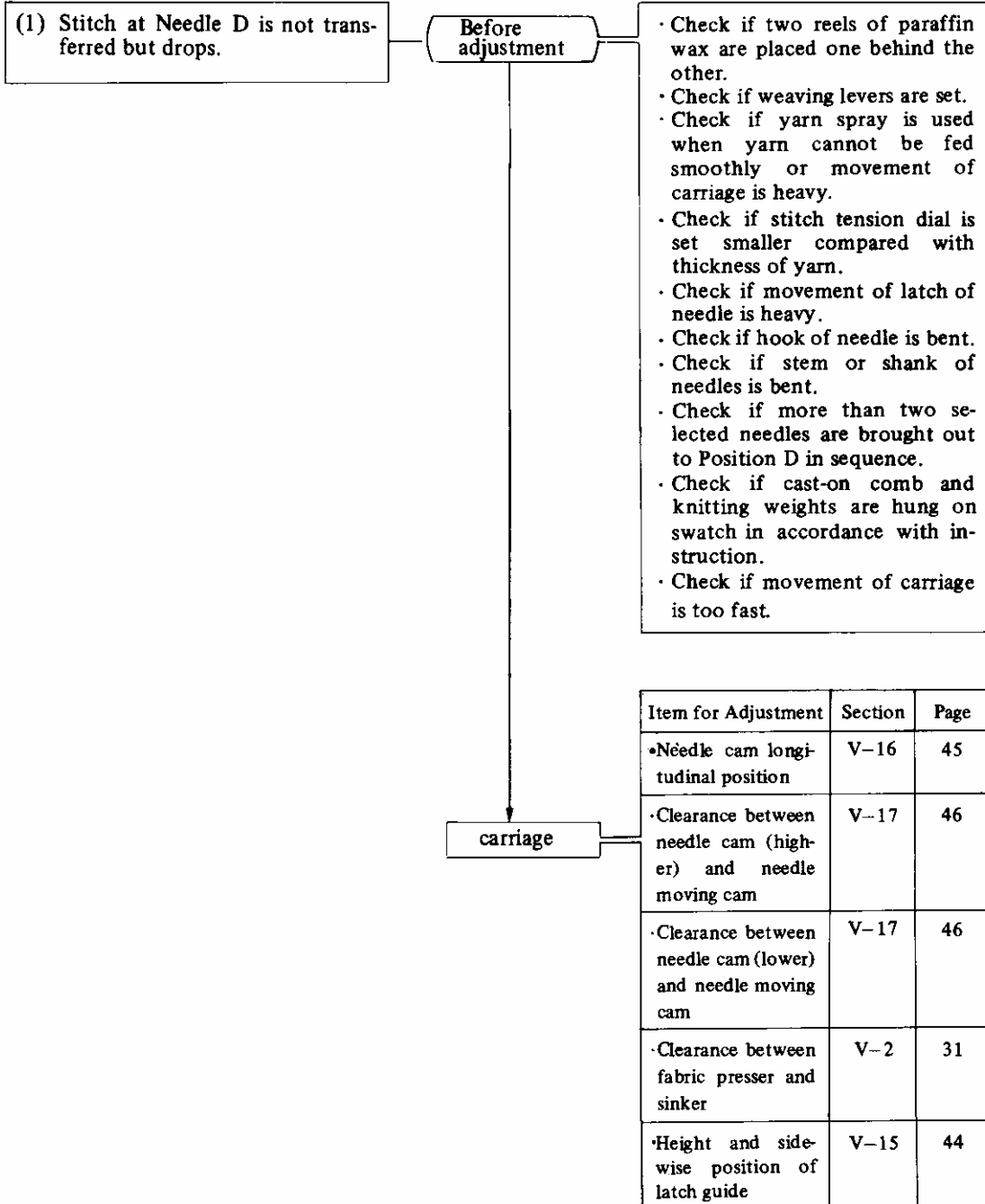

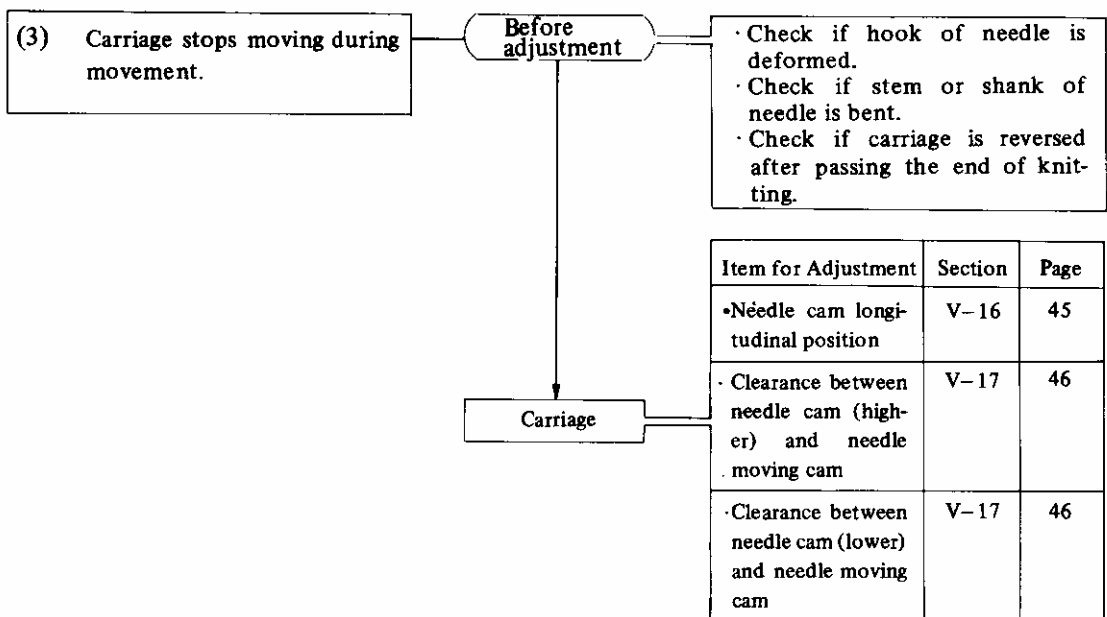
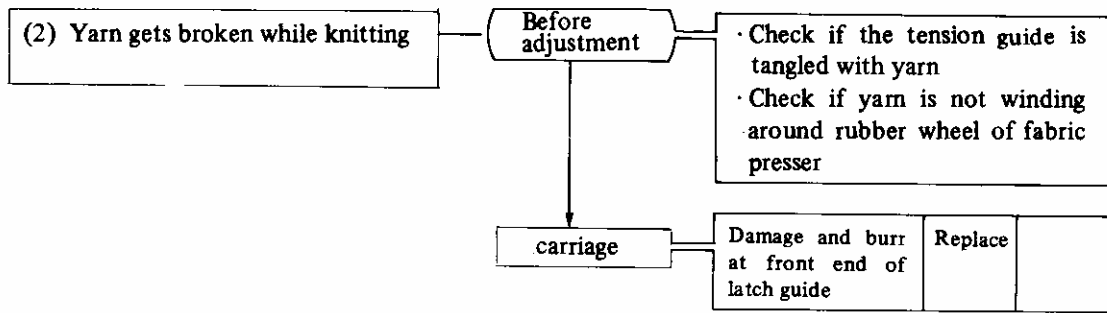

IV-5 Knitting by Card Needle Selection

(1) Needle to be selected according to pattern of card between 24 pitches or 8 pitches, is not selected.

**Before adjustment**

- Check if punch card is inserted aslant.
- Check if pattern perforation of punch card has been punched out of center.

**Carriage**

Item for Adjustment	Section	Page
• Play of carriage to needle bed in vertical direction	V-1	30
• Improper position of pattern drive pin	VI-2 VI-3	48 49

**Needle bed**

• Height of needle selection base drum	V-14	43
• Assembling position of selection pin stopper	VI-12	60
• Heavy movement of selection plate	VI-12	60
• Heavy movement of selection pin connecting plate	VI-12	60
• Assembling position of card drum shaft	VI-13	67
• Failure of operation of selection pin 1 in vertical direction	VI-12	60
• Breakage of selection pin operating rod	VI-12	60
• Position of selection pin holder plate	V-11	39

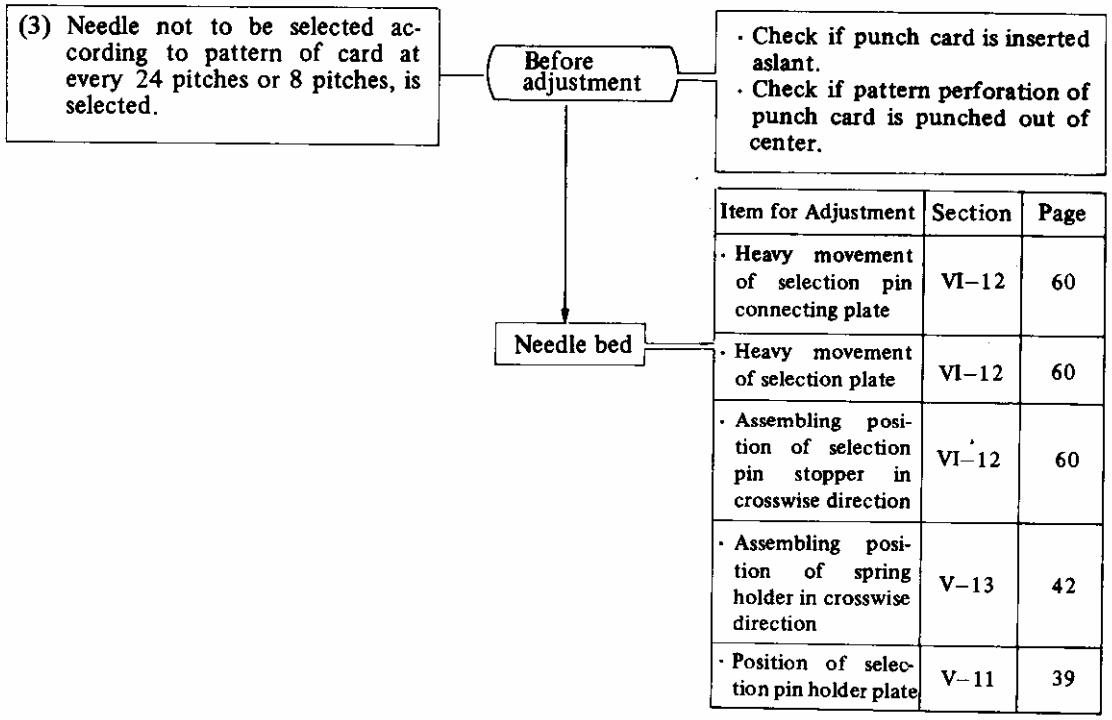
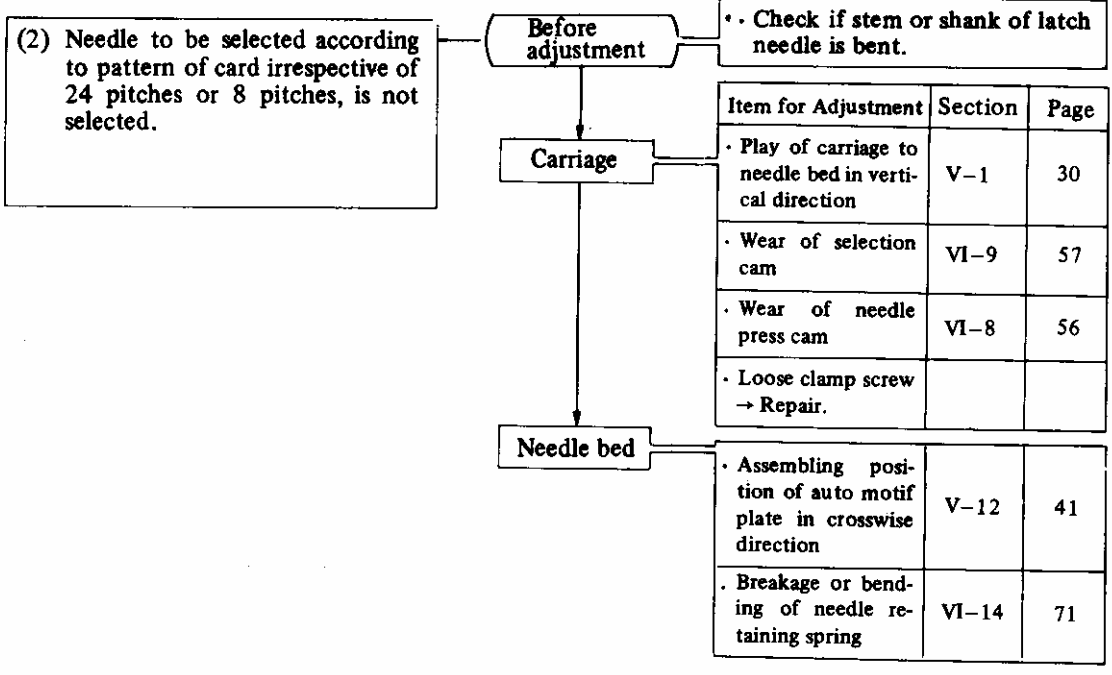



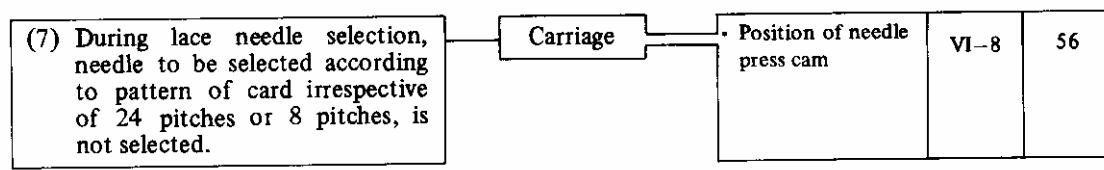
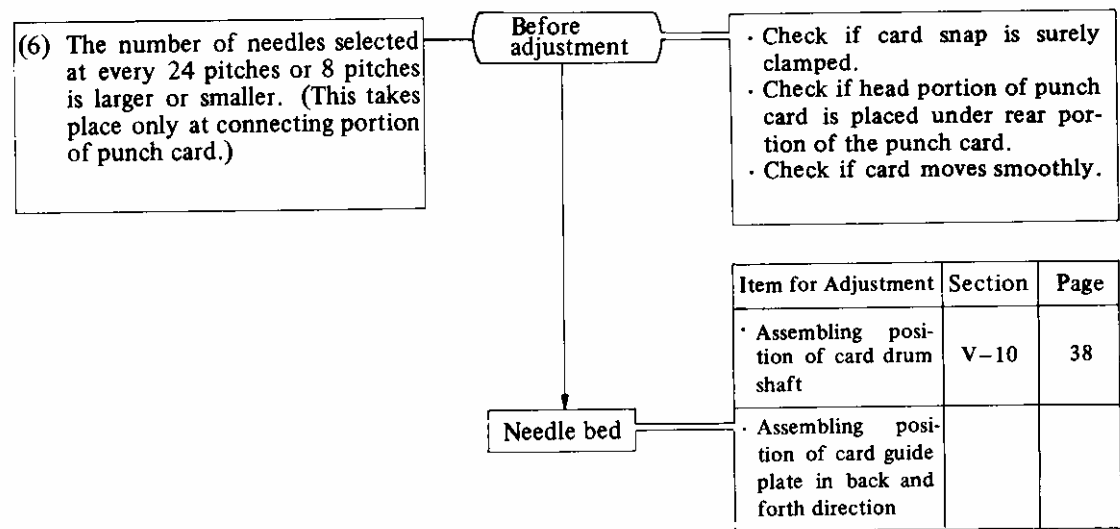
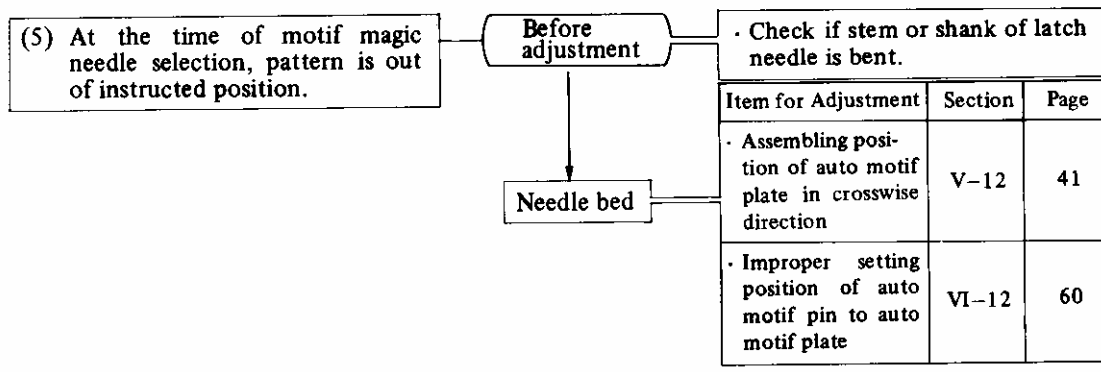
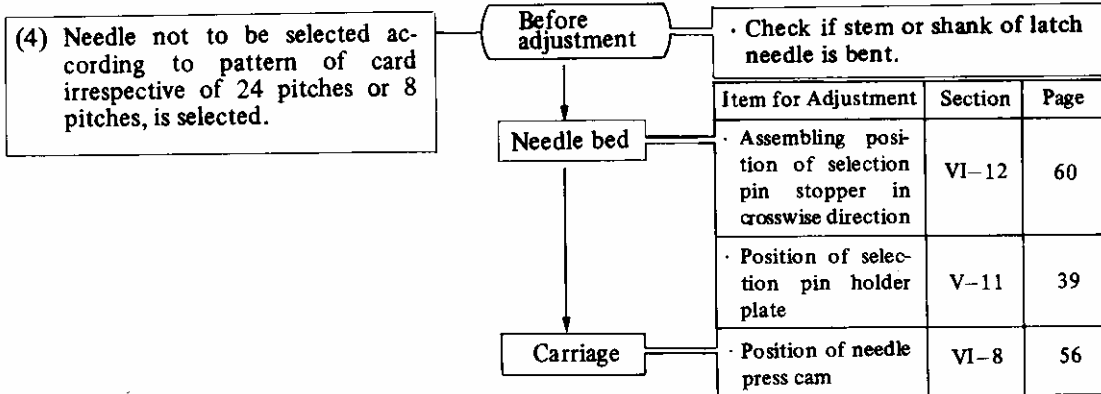

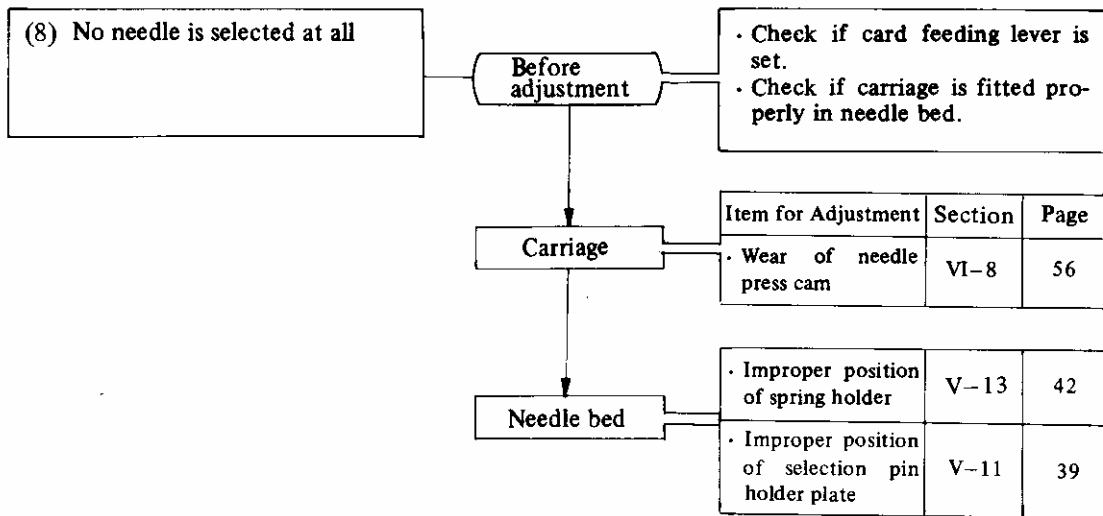

IV-6 End Needle Selection

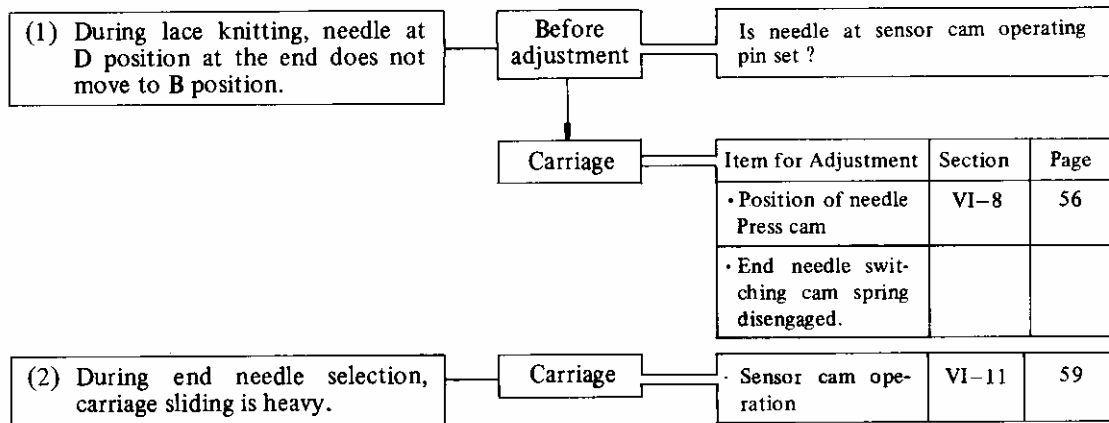

## V. ADJUSTMENT OF EACH PART

### V-1 Clearance between Carriage and Needle Bed

#### EXAMINATION

- (1) Holding the right and left rear foot (1) of the carriage, move it in the arrow directions as indicated in Fig.-1.

Play of the needle bed rear rail to the carriage rear rail in the vertical direction should be 0.05 to 0.35 mm.

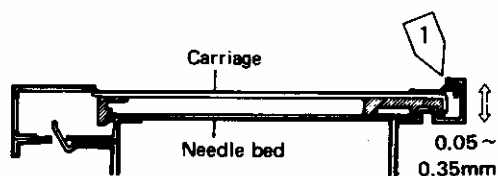

Fig.-1

#### ADJUSTMENT

- (1) Loosen the clamp screw (2) on the adjusting plate of the rear rail (3).
- (2) When play in the vertical direction is large at the rear rail, shift the adjusting plate in direction A, and then fasten the clamp screw firmly.  
When the movement of the carriage is heavy and so there is no play in the vertical direction, shift the adjusting plate in Direction B and fasten the clamp screw securely.
- (3) If still unadjustable in the above procedure, replace the butt releaser because the rear foot (butt releaser) of the carriage is worn.

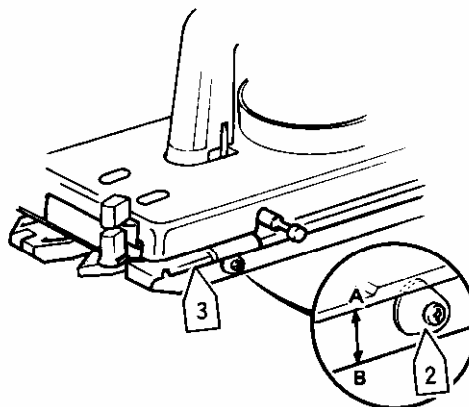

Fig.-2

## V-2 Clearance between Fabric Presser and Sinker

### EXAMINATION

- (1) Fit the carriage on the needle bed, and set the carriage in the arrow direction. Then, insert SST1-1 (1 mm) into the clearance between the front end of the fabric presser (4) and the sinker (5).

SST1-1 should be inserted lightly without play. (Fig.-3)

When SST is not used

Check by visual inspection if there is  $1 \pm 0.2$  mm clearance between the front end of the fabric presser and the sinker. (Fig.-4)

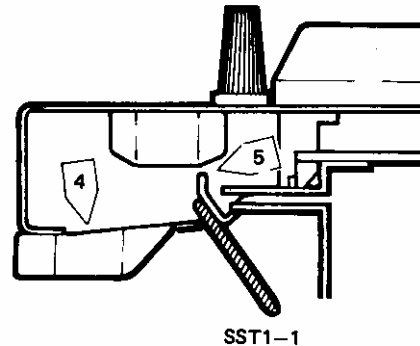

Fig-3

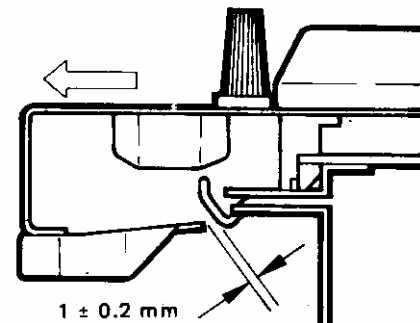

Fig.-4

### ADJUSTMENT

- (1) Remove the carriage from the needle bed, and slightly loosen three clamp screw (6) on the fabric presser. (Fig.-5)
- (2) When the clearance between the fabric presser and the sinker is large, slightly shift the fabric presser in direction A, and if it is small, shift it in direction B; then, temporarily fasten the clamp screws in either case.
- (3) Assemble the carriage on the needle bed, and check the clearance between the fabric presser and the sinker. At this time, the front ends (a)~(b) of the fabric presser should both keep the 1.0mm clearance.
- (4) After the adjustment, fasten three clamp screws securely from the bottom, and remove the carriage from the needle bed again. Then, further fasten the screws.

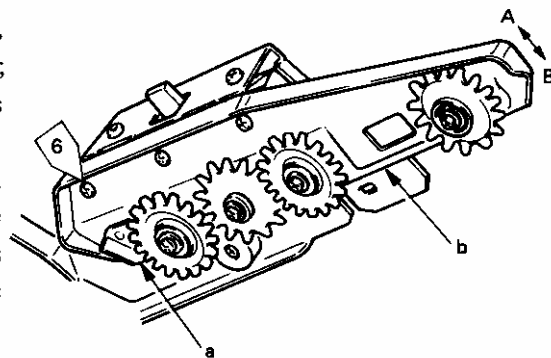

Fig.-5

V-3 Clearance between Front End of Fabric Presser and Latch Needle

EXAMINATION

- (1) Pattern dial . . . . . Plain Knitting
- (2) Latch needle. . . . . Two or three needle at position D

When moving the carriage, the clearance between the latch needle (7) brought out to position D and the plane of the front end of the fabric presser (4) should be  $-0.2$  to  $-0.4$  mm. (Fig.-6)

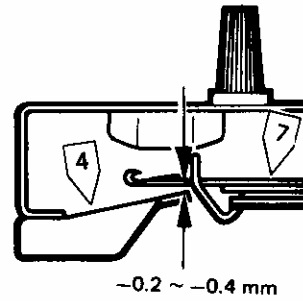

Fig.-6

ADJUSTMENT

- (1) When there is clearance between the front end of the fabric presser and the latch needle, adjust the fabric presser by pressing it in direction A by hand. (Fig.-7)
  - (2) Reversely, when the front end of the fabric presser is raising the latch needle at too high position, adjust the fabric presser by pressing it in direction B by hand.
- \* When the fabric presser has been deformed because the carriage was dropped from the stand, etc., replace the fabric presser ass'y.

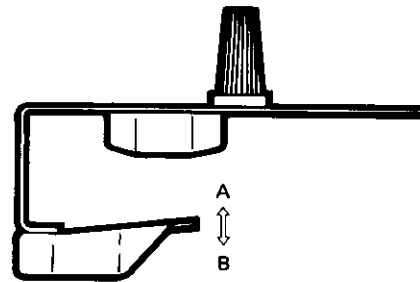

Fig.-7

#### V-4 Position of Latch Brush

##### EXAMINATION

- (1) Pattern dial . . . . . Plain knitting
- (2) Latch needle. . . . . Ten needles at position E

When closing the latch (8) of the latch needle to the hook (9) side (Fig.-8) and moving the carriage, the latch of the needle should contact the latch brush (10) and be open. (Fig.-9)

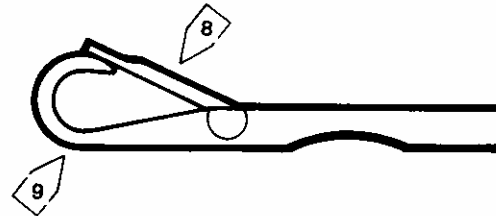

Fig.-8

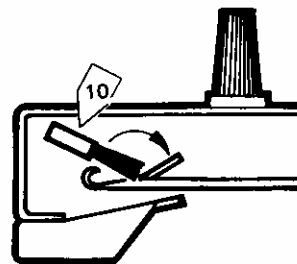

Fig.-9

##### ADJUSTMENT

- (1) When the latch does not open because the bristles of the latch brush are deformed, replace the latch brush.
- (2) Check if the clamp screw on the latch brush is loose. If it is loose, fasten it.

\* To replace, use the following method. (Fig.-10)

Remove two yarn feeder mounting screws (11) from the fabric presser and dismount the yarn feeder.

• Unscrew two clamp screws on the latch brush, and remove the latch brush. Or fasten the clamp screw.

(12)

• Assemble in the reverse procedure of removal, and be sure to adjust the clearance between the fabric presser and the sinker. (Refer to V-2.)

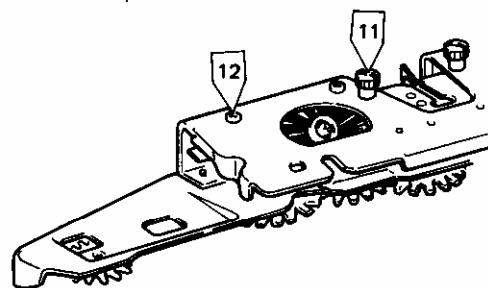

Fig.-10

## V-5 Clearance between Yarn Feeder and Latch Needle

### EXAMINATION

- (1) Pattern dial . . . . . Fair isle knitting
- (2) Latch needle (7) . . . . . Two or three needles at position D

Move the carriage, and check by visual inspection if the clearance between the latch needle (7) brought out to position D and the yarn feeder (13) is 0.45 ~ 0.95 mm. (Fig.-11)

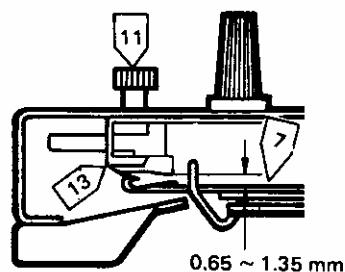

Fig.-11

### ADJUSTMENT

- (1) Remove two yarn feeder clamp screws (11) from the fabric presser, and remove the yarn feeder.
- (2) When the clearance between the yarn feeder and the latch needle is large, adjust by bending the yarn feeder in direction B in Fig.-12, and when the yarn feeder is too close to the latch needle, adjust by bending the yarn feeder in direction A.
- (3) When the adjustment cannot be done by hand because the yarn feeder is deformed too much, replace the yarn feeder.

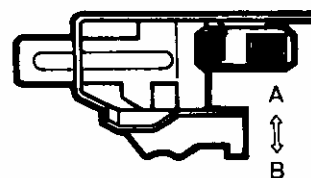

Fig.-12

## V-6 Crack and Burr of Yarn Feeder

### EXAMINATION

Thread the yarn feeder removed from the fabric presser (the yarn feeder on the side yarn slackens) with the yarn with which the upper tension was threaded. Then, changing the position of yarn until the yarn comes into contact with the end face of the yarn feeder hole, loosen the yarn held in hand, and check if the yarn is caught somewhere. (Fig.-13)

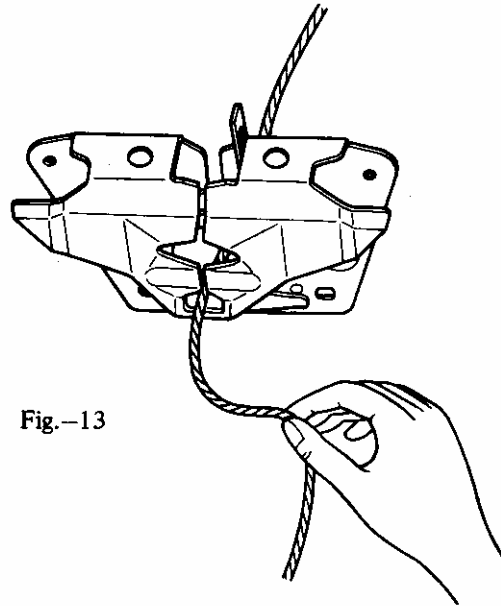

Fig.-13

### REPAIR

- (1) When the yarn is caught somewhere because there is crack or burr, correct the crack or the burr using fine-meshed files (a set of 12 files) or sand paper (#800 ~ #1200). (Use care to the shaded portion in Fig.-14)
- (2) When the crack is large and impossible to correct, replace the yarn feeder.

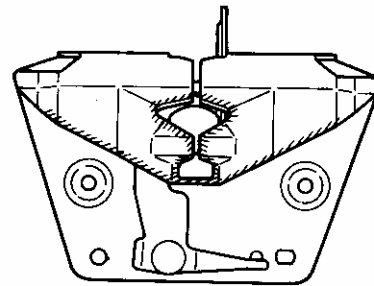

Fig.-14

## V-7 Crack and Burr of Fabric Presser

### EXAMINATION

Remove the fabric presser, and check if there is crack or burr on the front end of the fabric presser.

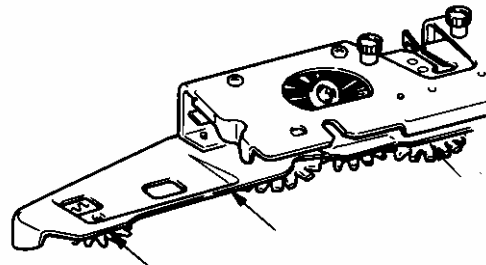

Fig.-15

### REPAIR

If there is crack or burr, correct the crack or burr using fine-meshed files (a set of 12 files) or sand paper (#800 ~ #1200).



## V-8 Vertical Position of Weaving Brush

### EXAMINATION

Setting the weaving knob (14) to the position marked "+", check by visual inspection if the dimension between the weaving brush (15) and the front end of the fabric presser is located at the position indicated in Fig.-16

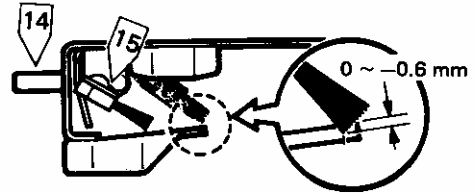

Fig.-16

### ADJUSTMENT

If the clearance between the weaving brush and the front end of fabric presser is too large, slightly loosen the weaving brush holder tightening screw (16) and move the weaving brush holder up and down. (Fig.-17).

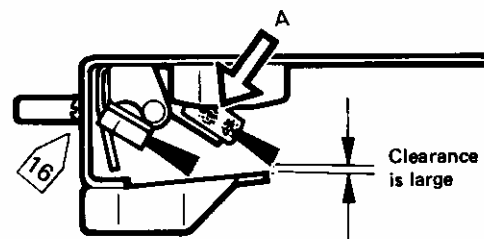

Fig.-17

## V-9 Assembling Position of Knitting Cam

### EXAMINATION

- (1) Set the pattern dial to "E", the stitch tension dial to "3", insert the SST22 between the knitting cam and partial knitting cam, and turn the stitch tension dial toward "5".

Longitudinal dimensional difference between the knitting cams (17) and (18) should be within 0.05 mm. (Fig.-18)

- When SST is not used

Look at the knitted fabric and check that there are large and small stitches at every other row. (Fig.-19)

### ADJUSTMENT

- When SST22 is used

Insert the SST 22 between the knitting cam and partial knitting cam, loosen the tightening screw in the knitting cam guide plate upper adjusting plate (19), and turn the stitch tension dial toward "5". When the right and left knitting cams (17) and (18) make contact with the SST22, tighten the screw in the knitting cam guide plate upper adjusting plate (19). (Fig.-18)

- When SST is not used

When making the above adjustment, make fine adjustment while checking during plain knitting.

- (1) When larger stitches are made at the time of leftward movement, slightly loosen the clamp screw on the knitting cam, and guide plate upper adjusting plate (19), and move the adjusting plate slightly leftward. (Fig.-20)
- (2) When the larger stitches are made at the time of rightward movement, slightly move the adjusting plate rightward. (Fig.-21)

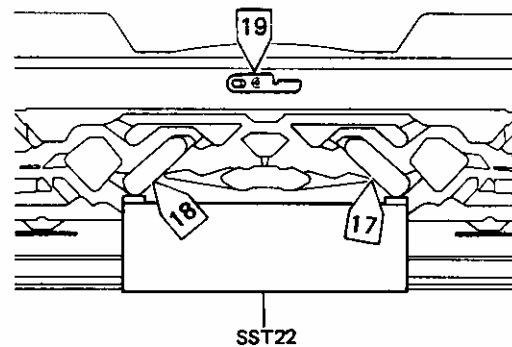

Fig.-18

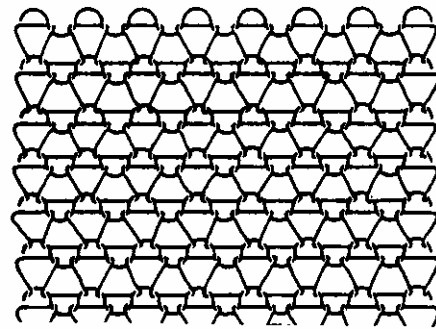

Fig.-19

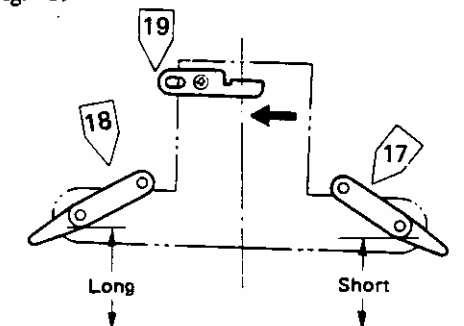

Fig.-20

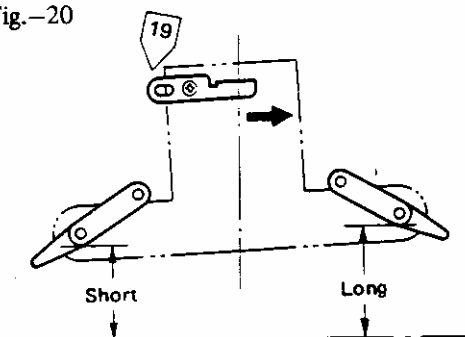

Fig.-21

## V-10 Position of Card Drum Shaft

### EXAMINATION

- (1) Referring to (1) ~ (5) in VI-12, remove the pattern board.

Pass SST6 into the positioning hole of the card drum shaft (20), and check if SST passes lightly through the positioning hole of the jacquard base plate (21). Since the positioning hole is provided on right and left, check both of them. (Fig.-22)

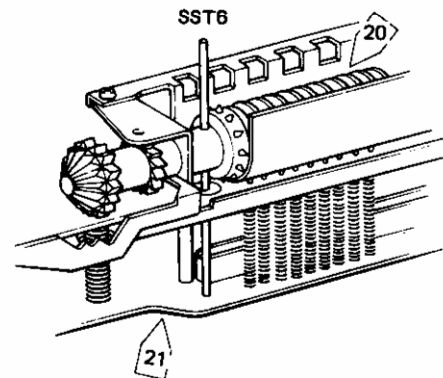

Fig.-22

### ADJUSTMENT

- (1) When SST6 cannot be passed into the positioning hole, loosen two clamp screws (22) on the card drum shaft.
- (2) Pass SST6 into the positioning holes of the card drum shaft and the jacquard base plate. Then, fasten the clamp screw on the card drum shaft on the side SST was passed through. After that, pass SST6 into the positioning hole on the opposite side, and fasten the clamp screw.
- (3) After the adjustment, install the pattern board in the reverse procedure.

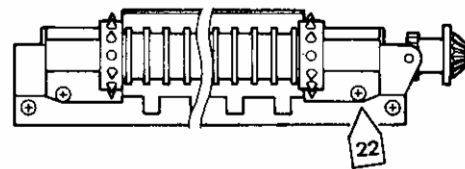

Fig.-23

**V-11 Position of Selection Pin Holder Plate**

**EXAMINATION**

- (1) Referring to (1) ~ (9) in VI-12, remove the needle bed from the lower case.
- (2) Bring one latch needle at 30th position on the needle bed protection film to position D as indicated in Fig.-24.
- (3) Bring several needles on both sides of the needle in position D to position E. (Fig.-24)

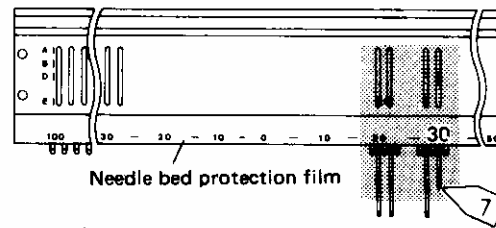

Fig.-24

○Checking the clearance between the shank of the needle (7) at position D and the selection plate (23) from the back side of the needle, rotate the needle selection base drum slowly by hand. (Fig.-25, 27)

○The selection plate starts to move sideways. When it approaches the needle closest, the needle should be in contact slightly with portion "a" of the selection plate. (Fig.-25, Fig.-27)

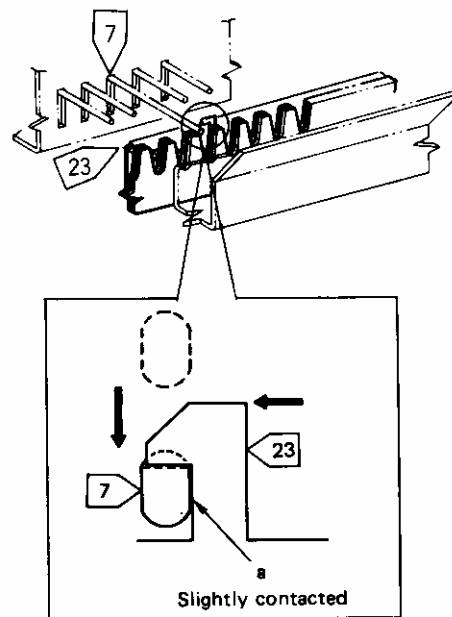

Fig.-25

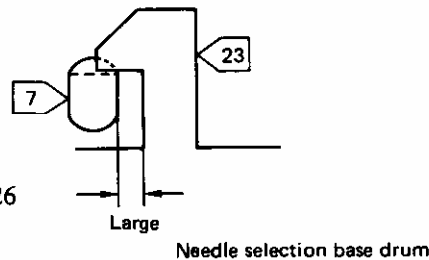

Fig.-26

**ADJUSTMENT**

- (1) If the clearance between the needle and portion "a" is too large, loosen two screws (26) on selection pin holder plate (25). Move the selection pin holder plate to A direction and tighten the screws. (Fig. 26, 27)

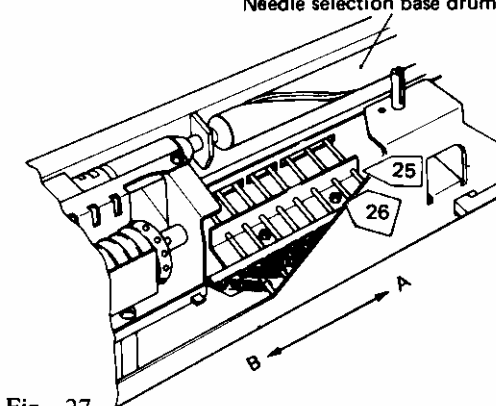

Fig.-27

- (2) In case the needle is in contact with portion "a" excessively, move it to B direction and tighten the screws. (Fig.-28, 29)

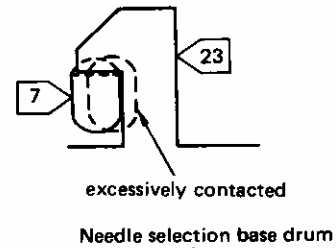

Fig.-28

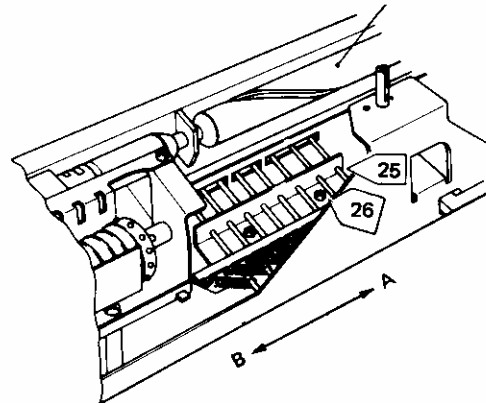

Fig.-29

#### CONFIRMATION

- (1) Put needle bed into lower case.
- (2) Set card lever of the carriage to position C.
- (3) When bringing out all the latch needles from position A to position B and sliding the carriage, all the needles should be selected.

\* When the correct clearance between the needle and the selection plate cannot be made even after adjusting the position of the selection pin stopper, check the installing position of selection pin stopper referring to VI-12 "Replacement of Selection Plate Holder Assy." (Fig.-30)

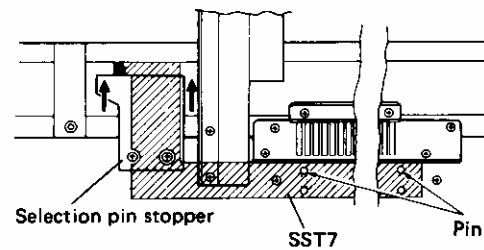

Fig.-30

#### INSTALLATION

- (1) Put needle bed into lower case and follow the steps of removal vice versa.

## V-12 Position of Auto Motif Plate (Motif Magic Plate)

### EXAMINATION

- (1) Auto motif dial . . . . . “●” position
- (2) Referring to (1) ~ (9) in VI-12, remove the needle bed from the lower case, and remove the knit tracer base plate, also.

○The latch needle (7) should be located at the centre of the concave of the auto motif plate (44) (Fig.-31)

○When setting the motif dial at “1”, the latch needle (7) should be located at the centre of the convex of the motif magic plate (44) at the position of excepting Motif pattern. (Fig.-32A)

### ADJUSTMENT

- (1) Loosen the clamp screw on the auto motif plate stopper (27), and adjust the position of the auto motif plate by shifting it in the directions of A and B so that the needle (7) is located at the centre of the concave of the auto motif plate. (Fig.-32)
- (2) Loosen the clamp screw from back of the needle bed. Adjust the position of the Auto motif plate by shifting it in the direction of A and B so that the needle (7) is located at the centre of the convex of the auto motif plate. (Fig.-32B)

### CONFIRMATION

- (1) Fit the carriage complete on the needle bed.
- (2) Set the card lever of the carriage to position C.
- (3) When bringing out all the latch needles from position A to position B and sliding the carriage, all the needles should be selected.
- (4) When switching the auto motif dial in turn, the needle should be selected, at each of the position according to the position indicated by the needle bed protection film.
- (5) After the adjustment, install the knit tracer base plate, and referring to (1) ~ (9) in VI-12 for the subsequent procedure, install the other parts.

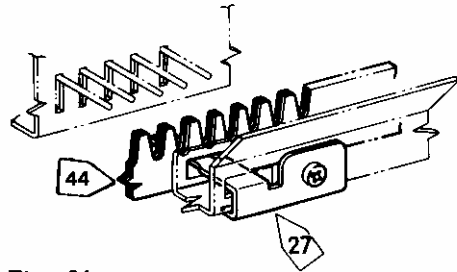

Fig.-31

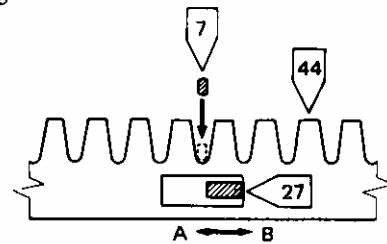

Fig.-32

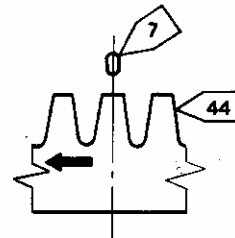

Fig.-32A

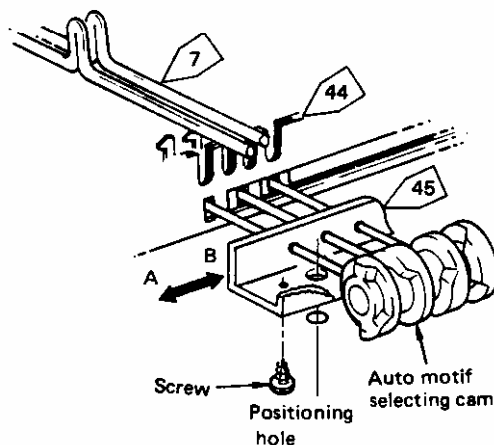

Fig.-32B

### V-13 Position of Spring Holder

#### EXAMINATION

- (1) Referring to (1) ~ (9) in VI-12, remove the needle bed from the lower case.

Check by visual inspection that the positioning hole of the spring holder (28) is properly aligned with the positioning hole of the jacquard base plate (21). (Confirm using SST8.)

(Fig.-33)

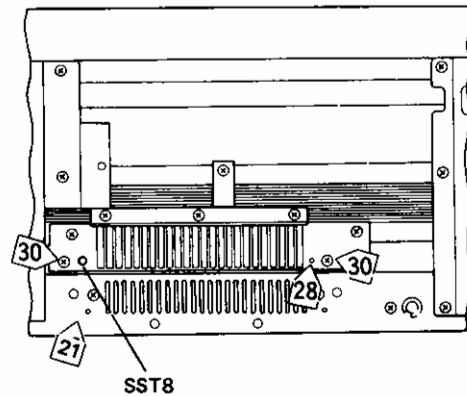

Fig.-33

#### ADJUSTMENT

- (1) If the positioning hole of the spring holder is not properly aligned with the positioning hole of the jacquard base plate, loosen two clamp screws (30) on the spring holder.
- (2) Insert SST8 into the positioning hole and fasten the clamp screws.

\* If the spring holder is shifted to the right under the condition as shown in Fig.-33, the clearance between the selection pin operating rod (31) and the selection pins 2 (32) becomes small, the vertical movement of the selection pin operating rod becomes heavy, and the movement of the carriage becomes heavy.

· If the spring holder is shifted to the left, the clearance between the selection pin 2 and the selection pin operating rod becomes large, so if the selection pin operating rod moves in the vertical direction, the crosswise movement of the selection pin 2 becomes small (the amount of movement of the selection plate becomes small), thereby resulting in failure of needle selection.

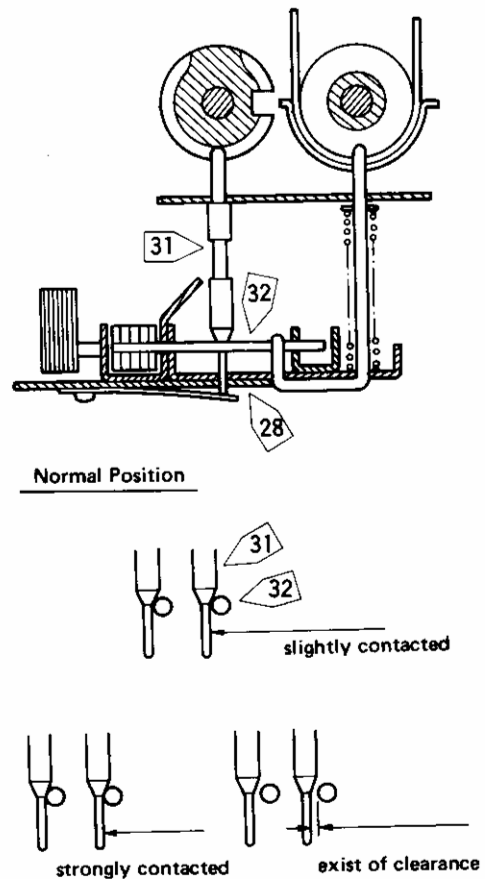

Fig.-34

## V-14 Height of Needle Selection Base Drum

### EXAMINATION

- (1) Referring to (1) ~ (5) in VI-12, remove the pattern board.

When putting SST5 at the position of the needle selection base drum shaft (33) and pressing portion A of SST5 by hand, the clearance between the needle bed and portion B of the lower part of SST5 should be less than 0.1 mm. Check four bearings of the needle selection base drum. (Fig.-35)

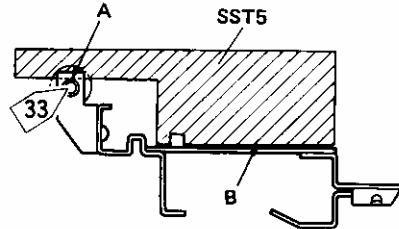

Fig.-35

### ADJUSTMENT

- (1) When there is clearance between SST5 and portion "a" of the needle bed;
  - Loosen the clamp screw (34) on the needle selection base drum bearing. Then, by lowering the needle selection base drum bearing, adjust until there is no clearance between the needle bed and SST. (Fig.-36)
- (2) When there is clearance between SST5 and portion "b" of the needle bed;
  - Loosen the clamp screw on the needle selection base drum bearing. Then, by raising the needle selection base drum bearing, adjust until there is no clearance between the needle bed and SST. (Fig.-37)
- (3) After the adjustment, install the pattern board.

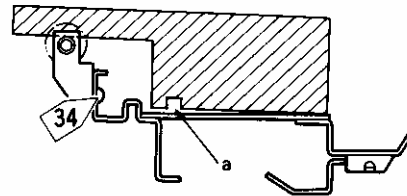

Fig.-36

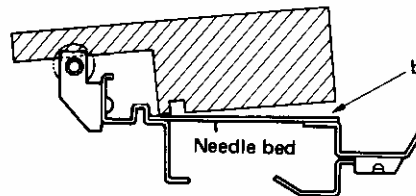

Fig.-37



## V-15 Position of Latch Guide

### EXAMINATION

- The distance in sideways from portion "a" of the latch guide (37) to the needle cam (38) should be 2.8 – 3.0 mm (Fig.-39)
- The distance in height from portion "a" of the latch guide (37) to the needle cam (38) should be 1.0 – 1.2 mm (Fig.-40)

### ADJUSTMENT

- (1) Sideways position of latch guide  
Loosen the clamp screw (36), and adjust the position of latch guide (37) in sideways. (Fig.-40)
- (2) Height of latch guide  
Loosen the clamp screw (36), and remove latch guide (37). Adjust by bending the latch guide up and down. (Fig.-40)

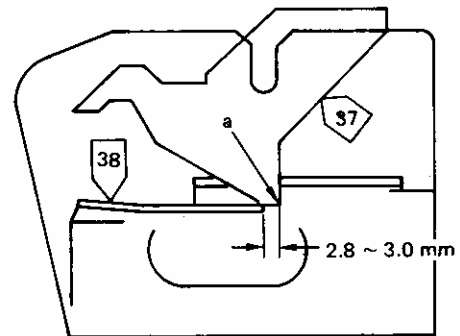

Fig.-39

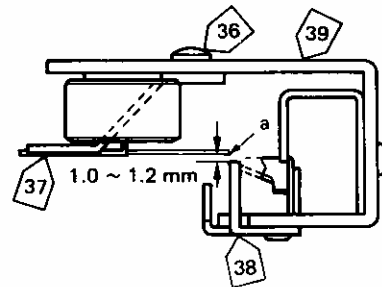

Fig.-40

- (1) Set the lace attachment (39) to the carriage.
- (2) Apply the SST2-2A to the datum surface of rear rail and set SST2-2B to the groove of SST2-2A (Fig.-41, Fig.-41A)

When portion "a" of the pin of SST2-2B is applied to the surface of lace cam, clearance between SST2-2B and the needle cam (40) should be  $\pm 0.1$  mm.

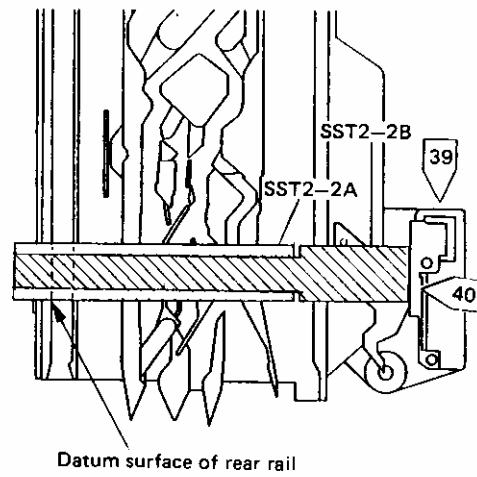

Fig.-41

#### ADJUSTMENT

Loosen two screws (35) in the needle cam (40) and move it forward until there is no clearance between the needle cam and SST2-2B. (Fig.-41A)

\*When adjusting the needle cam (20) back and forth, SST2-2B. and the needle cam should be parallel. (Tolerance in a and b: 0.1 mm)

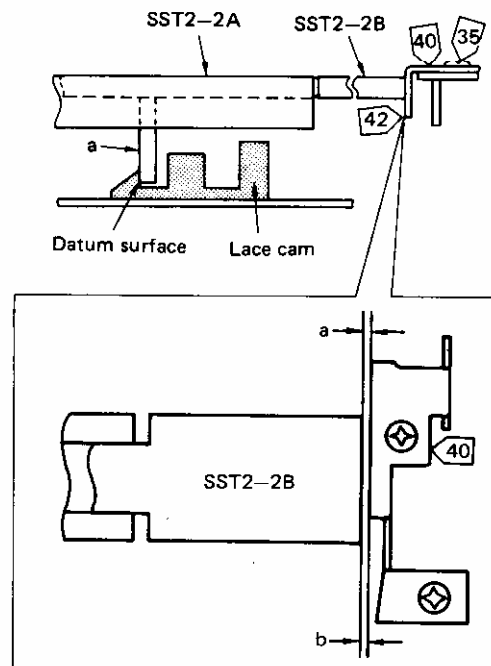

Fig.-41A

## V-17 Position of Needle Moving Cam

### EXAMINATION

During lace knitting using 1 × 1 needle selection, the selected latch needle is moved by the needle moving cam (43) and makes contact with the next selected latch needle, and must fall from the higher needle cam (38) to the lower needle cam (42). (Fig.-42)

\*This must always be done knitting a swatch.

\*The swatch must be knitted with medium 4 play yarn at stitch tension dial "5".

\*Check the first row of lace knitting after having 5 rows of plain knitting.

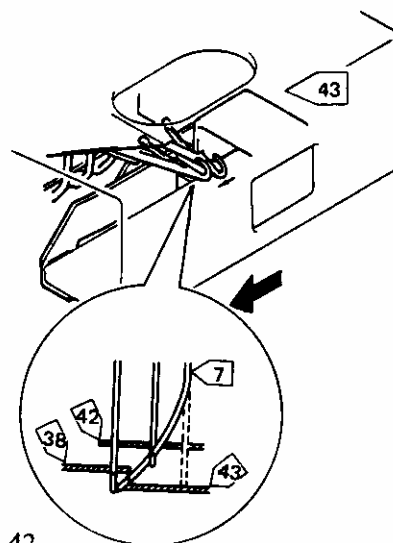

Fig.-42

### ADJUSTMENT

- (1) If the latch needle moved by the needle moving cam (43) falls to the lower needle cam (42) without making contact with the next selected latch needle, slightly loosen two needle moving cam tightening screws, move the needle moving cam in the carriage advancing direction, and make adjustment. (Fig.-43)
- (2) When the needle moved by the latch needle moving cam (43) falls to the lower needle cam (42) after pushing the next selected latch needle, move the needle moving cam in the reverse direction to the carriage advancing, and make adjustment.

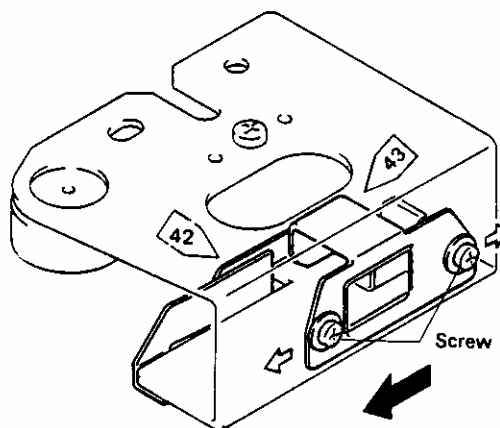

Fig.-43

## VI. REPLACEMENT OF MAIN PARTS

### VI-1 Replacement of Stitch Tension Dial and Pattern Dial

#### REMOVAL

- (1) Unscrew two clamp screws (handle shafts) on the carriage handle (1).
- (2) Remove the handle stopper (2) and the stopper spring (3) on the left side of the carriage handle, and remove the carriage handle. (Fig.-1)
- (3) Remove two tightening screws from the carriage cover (4), set the pattern dial (8) to "plain knitting" (P·L), and dismount the carriage cover. (Fig.-2)
- (4) Extract the stitch tension dial indicator plate (5) upward.
- (5) Rotate the stitch tension dial (6) toward "0", and extract the dial upward at the position where the groove of the stitch tension dial is set to the set pin of the dial shaft (7). (Fig.-3)
- (6) Set the transfer stitch lever (10) to "0", the pattern dial (8) to "plain knitting" (P·L) (the pattern dial groove is aligned with the dial shaft retaining pin). Pull the positioning spring (9) forward by hand and remove the pattern dial upward. (Fig.-4)

#### INSTALLATION

- (1) Install the pattern dial (8) and stitch tension dial (6) in the reverse procedure of removal.  
\*Check operation.
- (2) Install the stitch tension dial indicator (5) with the indicator on the front.
- (3) Tighten the carriage cover (4) with two screws.
- (4) Install the carriage handle (1) in the reverse order of removal.

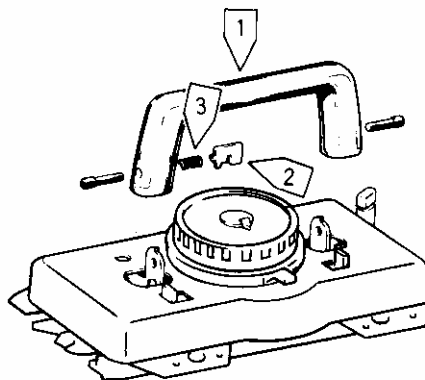

Fig.-1

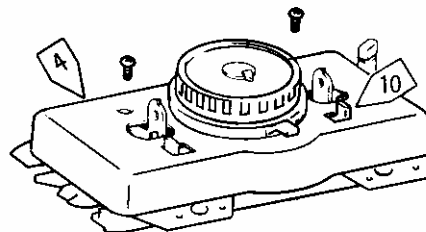

Fig.-2

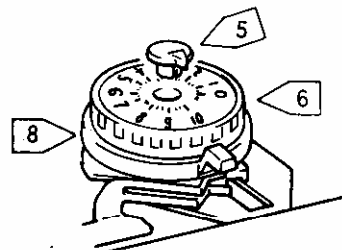

Fig.-3

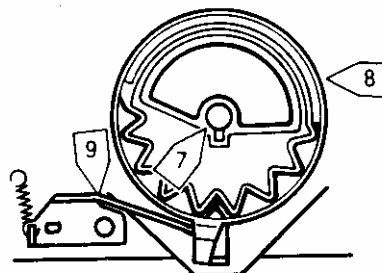

Fig.-4

## VI-2 Replacement of Carriage Handle Base Plate (Left) and Pattern Drive Pin

### REMOVAL

- (1) Remove the carriage handle and carriage cover.
- (2) Remove the rear foot spring (10).
- (3) Remove three tightening screws from the carriage handle base plate (11) and extract them leftward.  
\*If there are shim washers under the carriage handle base plate, be sure to insert them during reassembly.  
\*Do not remove the right and left carriage handle base plates at the same time (to keep proper parallelism of the pattern drive pin).
- (4) Press the pattern drive pin (12) in direction A to the nicked position of the carriage handle base plate at position a. Rotate the pattern drive pin in direction B to set the stop pin to the lower side. (Fig.-5, Fig.-6)
- (5) Return the pattern drive pin in direction C indicated by the arrow, and extract the spring (13). (Fig.-7)
- (6) Rotate the pattern drive pin, and set the stop pin to the upper side. Then, extract it from the carriage handle base plate in the arrow direction as shown in Fig.-8.

### INSTALLATION

- (1) Insert the shim under the screw fastening portion of the carriage handle base plate, and temporarily fasten it on the carriage cover. Then, set the dimension from the end of the pattern drive pin to the datum surface of the rear foot, using SST2-2A, and fasten the shim.
- (2) True up the end of the pattern drive pin and portion "a" of SST2-2A, and confirm that there is no clearance at portion "b" (Fig.-9)

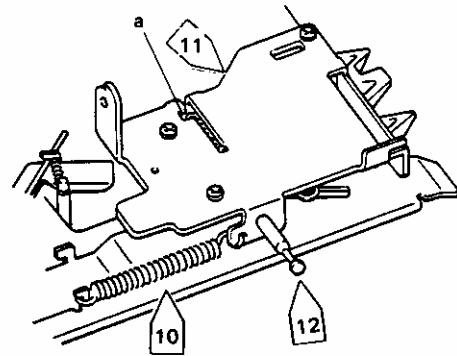

Fig.-5

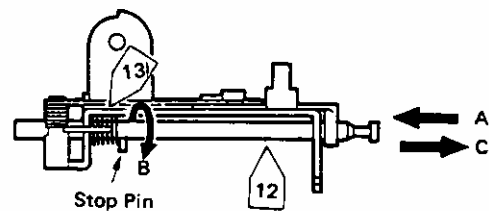

Fig.-6

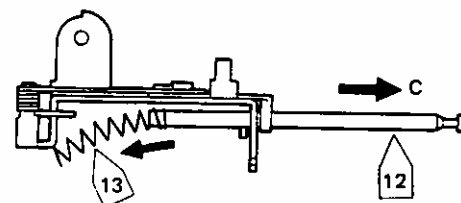

Fig.-7

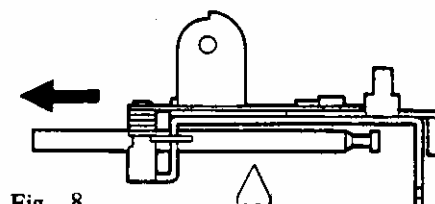

Fig.-8

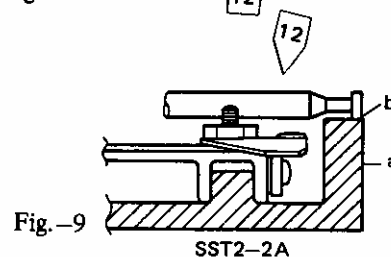

Fig.-9

- (3) Set the position of the pattern drive pin in the crosswise direction to the positioning hole of SST2-1, and fasten the carriage handle base plate. (Fig.-10)

**When SST is not used**

Before removing the carriage handle base plate, scribe a line on the carriage handle base plate, and when installing the base plate, set it to the scribed line.

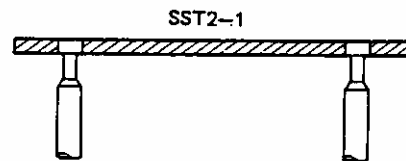

Fig.-10

### VI-3 Replacement of Selection Drive Rod Link and Carriage Handle Base Plate (Right)

#### REMOVAL

- (1) Remove the E stop ring (15) and shim washers from the selection drive rod link assembly (14) and dismount the selection drive rod link assembly.
- (2) Remove three tightening screws from the carriage handle base plate (right) (11).
- (3) Remove the base plate assembly (16).
- (4) Remove the selection switch knob (17).
- (5) Remove the selection switch cam spring (18).
- (6) Lift the carriage handle base plate (11) and extract the pattern drive pin (12) referring to steps (4) to (6) in REMOVAL of VI-2.
- (7) Extract and remove the carriage handle base plate from the selection switch lever (19).

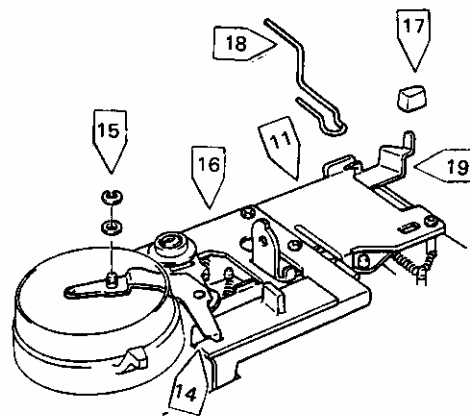

Fig.-11

\*If there are shim washers under the carriage handle base plate, be sure to insert them during reassembly.

#### INSTALLATION

- (1) Install in reverse order of removal.

#### ADJUSTMENT

Tighten the carriage handle base plate referring to ADJUSTMENT of VI-2.

#### VI-4 Replacement of Raising Cam, Knitting Cam and Variable Cam

##### REMOVAL

- (1) Remove the carriage handle and the carriage cover.
- (2) Remove the E stop rings (15) and shim washers from the selection drive rod link assembly (14).
- (3) Remove two tightening screws from the base plate (16).
- (4) Remove the base plate assembly (16).
- (5) Remove the spring firstly from the raising cam shaft, secondly from the hook of raising cam change lever (20), and lastly from the spring (29). (Fig.-13)
- (6) Remove the E rings (22) (23) on the raising cam shaft.
  - \*Remove the E ring (22) on the raising cam shaft by supporting the raising cam change lever in the arrow direction by hand.
- (7) Remove the shim washers under the E rings.
- (8) Extract the raising and knitting cam ass'y (24) from the back side of the carriage.
- (9) Remove the variable cam spring (25).
- (10) Remove the E ring and the shim washer which clamp the variable cam, and remove the variable cam (27).

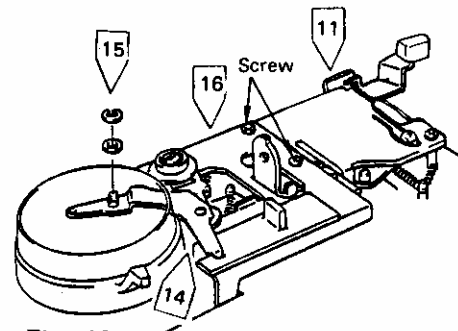

Fig.-12

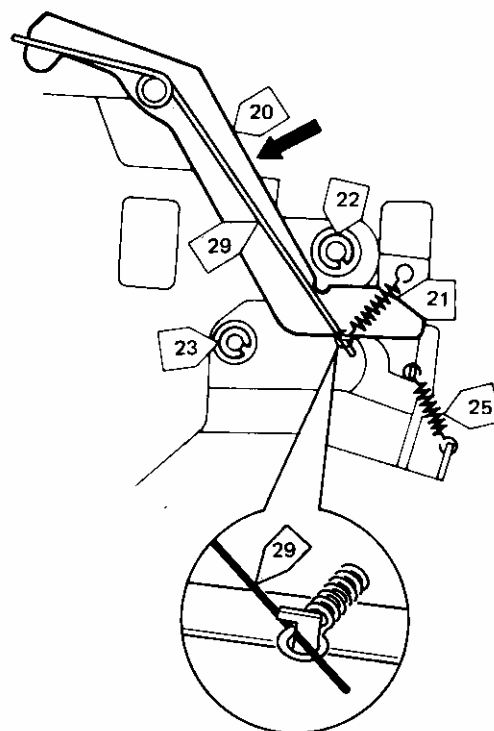

Fig.-13

## INSTALLATION

- (1) Insert the variable cam into the shaft. Be sure to fit the removed shim washer, and clamp it with the E ring. Hook the variable cam spring.
- (2) Set the swing cam to the centre position. While simultaneously inserting the raising cam and knitting cam (24) into the setting hole of the carriage, insert the setting hole of the protection cam (28) in alignment with the variable cam mounting shaft (26). Insert shim washers into the raising cam shafts (22) and (23) and clamp them with E stop rings.

\* Note that if the number of shim washers is small, play of the shaft in the vertical direction will become large. Reversely, if the number of shim washers is large, the movement of the raising and knitting cam will be heavy.

- (3) Hook the spring (21) firstly at the spring (29), secondly at the raising cam change lever (20), lastly at the raising cam shaft.
- (To prevent the spring coming off)
- (4) Install the base plate (16).
- (5) Install the selection drive rod link assembly (14), insert the shim washers into the shaft, and clamp with the E stop rings.
- (6) Install the carriage cover and the carriage handle.

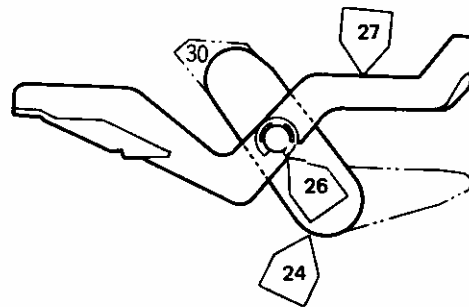

Fig.-14

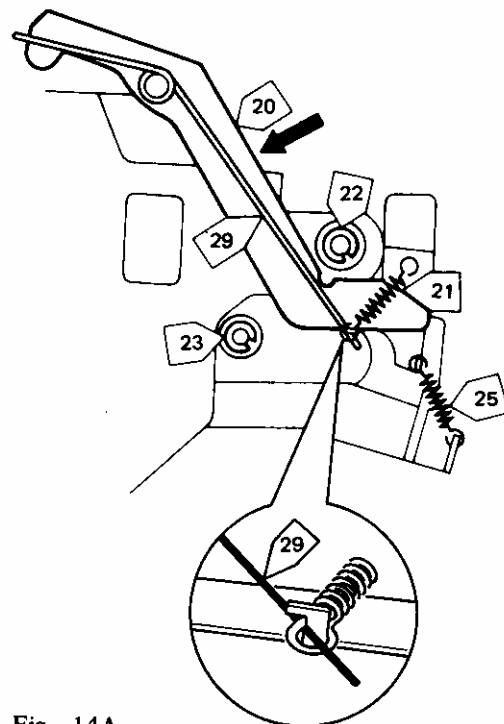

Fig.-14A



## VI-5 Replacement of Fair Isle Knitting Cam and Swing Cam

### REMOVAL

- (1) Set the pattern dial to "plain knitting". (P·L)
- (2) Unscrew the clamp screw on the swing cam (31), and shift the swing cam until the swing cam is disengaged from the fair isle knitting cam base (32). Then, remove the swing cam and the fair isle knitting cam collar (33) and the swing cam spring collar (30).
- (3) Remove the swing cam spring (34) from the fair isle knitting cam collar.
- (4) When the clamp screw on the fair isle knitting cam (35) is removed, the fair isle knitting cam base (32), the fair isle knitting cam (35) and the fair isle knitting cam collar (33) can be removed.
- (5) Remove the fair isle knitting cam spring (36) from the fair isle knitting cam collar (Fig.-15)

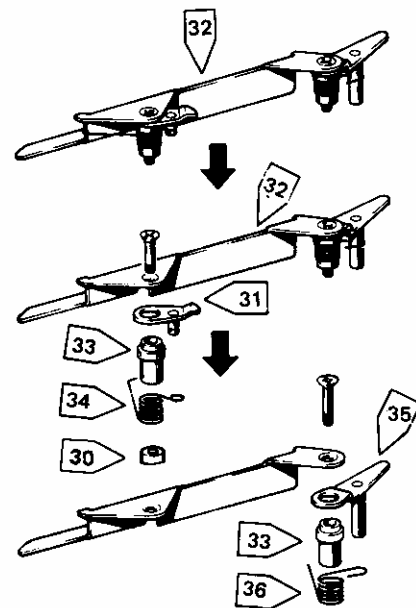

Fig.-15

### INSTALLATION

- (1) Set the fair isle knitting cam spring (36) and the fair isle knitting cam (35) on the fair isle knitting cam collar (33), and hook the spring end (A) at the fair isle knitting cam shaft.
- (2) Set the fair isle knitting cam collar to the installing position of the fair isle knitting cam base (32), and set the end (B) of the fair isle knitting cam spring to the position indicated in the figure at right. Then, place it on the installing position of the carriage cover, and temporarily fasten it using a clamp screw. (Fig.-16)
- (3) Set the swing cam spring (34) and the swing cam (31) on the fair isle knitting cam collar (33), and hook the spring end (A) at the swing cam shaft.
- (4) Set the swing cam spring collar (30) on the fair isle knitting cam collar (33).

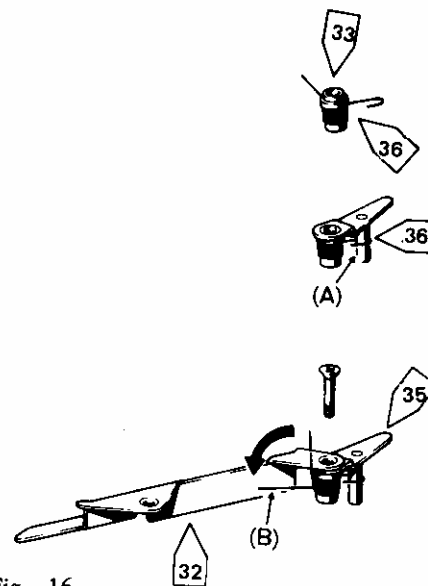

Fig.-16

- (5) Set the fair isle knitting cam collar to the installing position of the fair isle knitting cam base. At this time, hook the spring end (B) at Portion C of the fair isle knitting cam base. (Fig.-17)
- (6) Set the end of the swing cam (34) to the position where the end thereof should come to the inside of the variable cam (37), and fasten the screw.
- (7) Firmly fasten the screw which was temporarily fastened on the fair isle knitting cam (35) side.

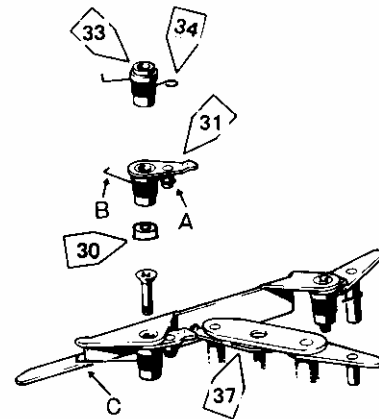

Fig.-17

## VI-6 Replacement of Tuck Cam and Tuck Cam Spring

### REMOVAL

- (1) Unscrew two clamp screws on the tuck cam (38). (Fig.-18)
- (2) Remove the tuck cam guide (40), and also the tuck cams, the fair isle knitting cam collars (33) and the tuck cam springs (39) on both sides, simultaneously. (Fig.-19)

\* Use care not to bounce the fair isle knitting cam collar and the like by the force of the spring.

### INSTALLATION

- (1) Pass two clamp screws into the tuck cam guide, and set the fair isle knitting cam collars, the tuck cams, the tuck cam springs in the above sequence. (Fig.-20)
- (2) Hook portion "a" of the tuck cam spring at the tuck cam, and portion "b" at the fair isle knitting cam collar. (Fig.-21)
- (3) Since the tuck cam is located inside by the force of the spring, extend it to the outside. Turn over the tuck cam using care not to remove the fair isle knitting cam collar and the spring, and while pressing the tuck cam in direction "c" indicated by the arrow, place it on the installing position of the carriage. (Fig.-22)
- (4) Fasten the clamp screws on both sides. After fastening the screws, check if the tuck cams return to the original positions by the force of the spring, and if the tuck cams operate normally by setting the pattern dial to "tuck knitting" and "plain knitting" alternately.

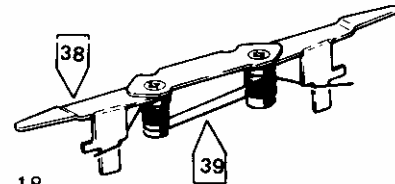

Fig.-18

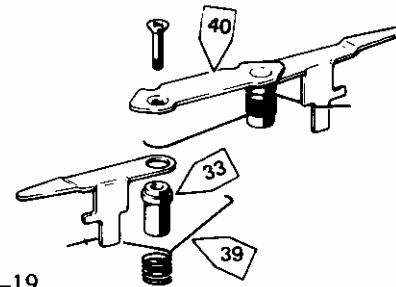

Fig.-19

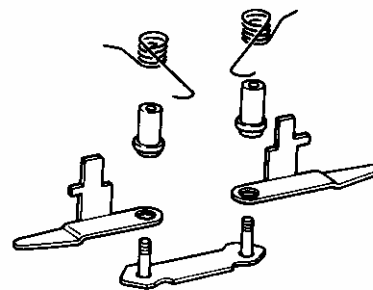

Fig.-20

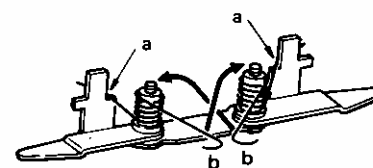

Fig.-21

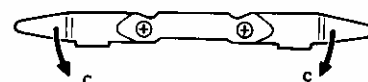

Fig.-22

## VI-7 Replacement of Guide Cam and Valve Cam

### REMOVAL

- (1) Unscrew the clamp screw on the guide cam (41).
- (2) Remove the guide cam (41), and remove the valve cam washer (42), the valve cam (43), the guide cam collar (44) and the valve cam spring (45).

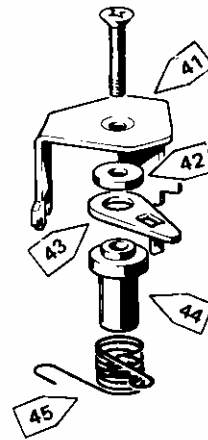

Fig.-23

### INSTALLATION

- (1) Set the valve cam spring (45) on the guide cam collar (44).
- (2) Set the valve cam (43) on the guide cam collar (44). Then, hook the valve cam spring at portion A of the valve cam, and set the valve cam washer (42).
- (3) Bring the parts, which have been set as described above, to the inside of the guide cam (41). Then, hook the end of the valve cam spring (45) at portion B, and pass the screw from above.
- (4) Insert the lower part of the guide cam into portion C of set hole of the base plate, and fasten the screw.

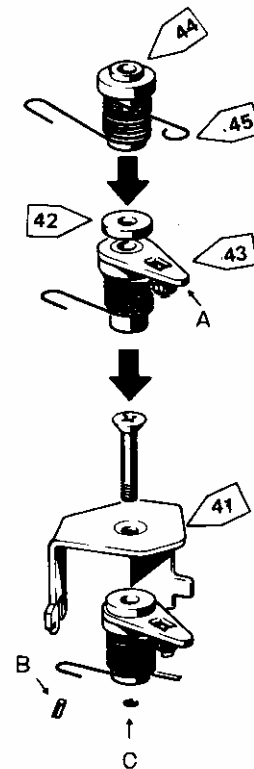

Fig.-24

## VI-8 Replacement of Needle Press Cam and Sorting Plates 1 and 2

### REMOVAL

- (1) Reverse the carriage. Remove two tightening screws from the protection cam (112) and dismount the protection cam.
- (2) Remove two tightening screws from the sorting plate 1 (113) and dismount the sorting plate 1.
- (3) Remove one tightening screw from the needle press cam (114) and dismount the needle press cam.
- (4) Remove one tightening screw from the sorting plate 2 (115) dismount the sorting plate 2. (Fig.-25)

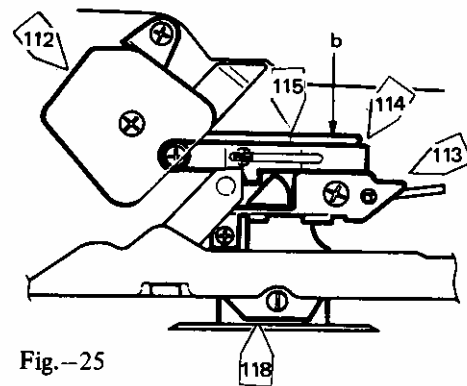

Fig.-25

### INSTALLATION

- (1) Align the hole in portion a of the sorting plate 2 (115) with the threaded hole in the carriage plate, (moving in direction A) and tighten one tightening screw B. firmly (Fig.-26A)
- (2) Set the one-way cam (116) to the needle press cam (114), temporarily tighten the screw, move the needle press cam (114) in direction of arrow until it make contact with the pin (117) of the sorting plate 2, and tighten the screw. (Fig.-26B)
  - There should not be any clearance between the needle press cam and portion "b" of the sorting plate 2. (Fig.-25)
  - Check the dimension in height of the sorting plate 2 and the needle press cam (Fig.-26-B)
- (3) Tighten two tightening screws in the sorting plate 1 (113).
- (4) Check the operation of the sensor cam (118).

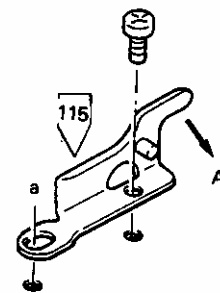

Fig.-26A

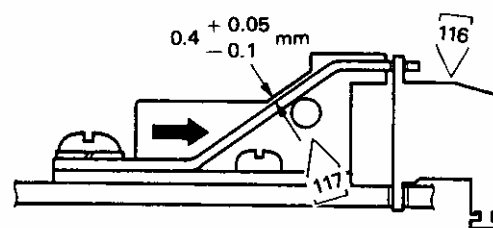

Fig.-26B

## VI-9 Replacement of Selection Cam

### REMOVAL

- (1) Remove the handle and carriage cover.
- (2) Remove the selection cam spring (120).
- (3) Remove two tightening screws from the selection cam (119) and dismount the selection cam. (Fig.-27)

### INSTALLATION

- (1) If shims have been used under the selection cam (119), insert them and install the selection cam with two tightening screws. (Fig.-27)
  - The distance from the end of the selection cam to the datum surface of needle bed should be  $3.65 \pm 0.15$  mm. (Fig.-27A)
  - If the dimension is too large, add shims under the selection cam.
  - If the dimension is too small, remove shims.
- (2) Turn the carriage face upward and hook the spring (120) at portion A of the selection cam and also at portion B of the lace switching plate (121) from the carriage rear using the latch needle. (Fig.-28)
- (3) Check that the selection cam operates properly.

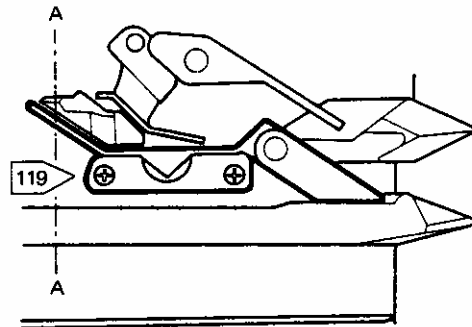

Fig.-27

A-A Vertical Section

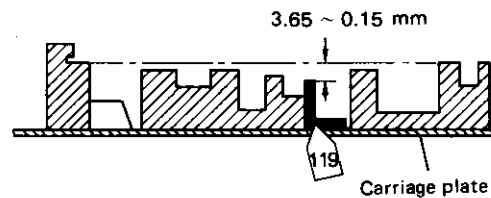

Fig.-27A

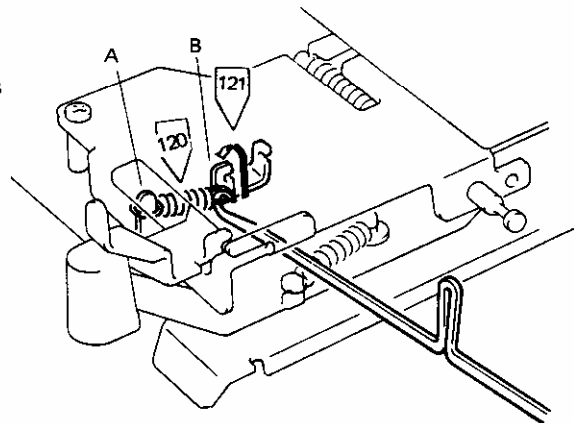

Fig.-28

## VI-10 Replacement of Lace Cam

### REMOVAL

- (1) Remove the handle and carriage cover.
  - (2) Remove the carriage handle base plate (right or left). (Refer to VI-2-1 or 2-2.)
  - (3) Remove the raising cam spring (122).
  - (4) Remove the lace switching cam 2 spring (123).
  - (5) Remove the lace swing cam spring (124). (Fig.-29)
  - (6) Remove three tightening screws from the partial knitting cam (125) and dismount the partial knitting cam.
  - (7) Remove two tightening screws from the lace cam (126).
  - (8) Push the selection cam (119) with fingers and dismount the lace cam.
  - (9) Remove the lace swing cam (128).
  - (10) Remove the E stop rings from the raising cam (129) and lace switching cam 2 (130), and dismount the raising cam and lace switching cam. (Fig.-30)
  - (11) Remove the lace switching cam 4 (131) and spring.
- \*Exercise care not to let the spring off. (Fig.-31)

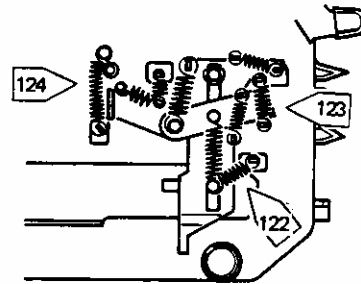

Fig.-29

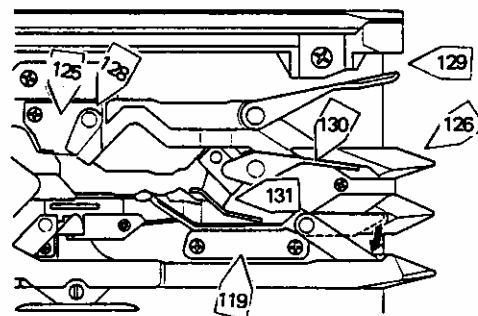

Fig.-30

### INSTALLATION

- (1) Insert half of the lace switching cam 4 (131) shaft, then insert the spring (132) in the arrow direction, and set it.
- \*Check the movement of the lace switching cam 4.
- (2) Insert the lace switching cam 2 (130) and lace swing cam (128).
  - (3) Turn over the lace cam (126), insert the shims, and fit the E stop rings.
  - (4) Install in reverse order of steps (3) to (9) in REMOVAL.
  - (5) Check that each cam operates properly.
  - (6) Install in reverse order of steps (1) to (2) in REMOVAL.

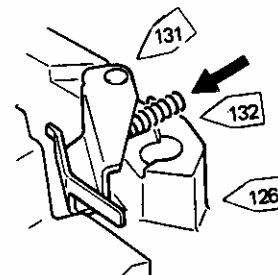

Fig.-31

## VI-11 Replacement of End Needle Selection Cam

### REMOVAL

- (1) Reverse the carriage. Remove six tightening screws from the butt releaser (137) and dismount the butt releaser, carriage brake spring (133), and sensor cam (118). (Fig.-32)
- (2) Remove two tightening screws from the sorting plate 1 (113) and dismount the sorting plate 1.
- (3) Using the pick-up hook (134) of the rib knitter, hook and hold the end needle selection cam spring (135) and dismount the end needle selection cam (136). (Fig.-33)

\*If the spring cannot be held, remove the handle base plate, referring to VI-2.

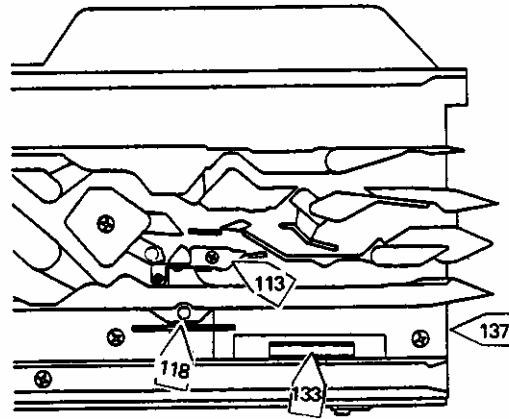

Fig.-32

### INSTALLATION

- (1) Using the pick-up hook (134), hook the held spring (135) at portion A of the end needle selection cam (136). (Fig.-33)
- (2) Install the sorting plate 1 (113).  
\*Check the end needle selection cam (136) operation.
- (3) Place the right and left sensor cams on the right and left end needle selection cams. (Fig.-34)
- (4) Place the carriage brake spring (133) on the position where the carriage assembly had been, and mount the butt releaser (137).
- (5) Check the operations of the sensor cam and end needle selection cam.

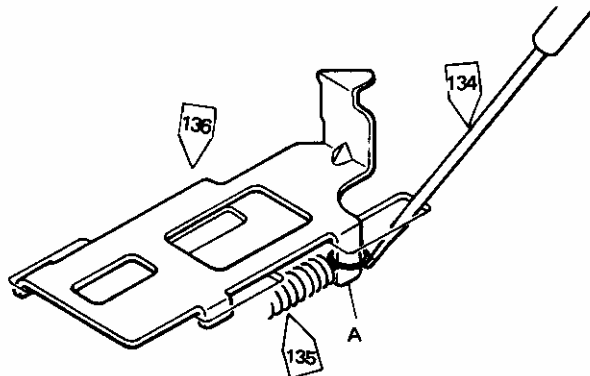

Fig.-33

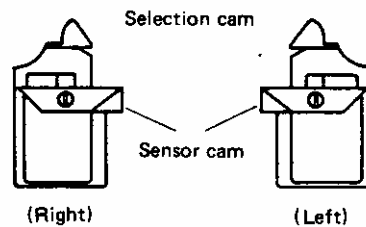

Fig.-34



## VI-12 Replacement of Selection Plate Holder Ass'y

### REMOVAL

\* Since there are various types of screws different in length, it is recommended to place the screws on or near the respective parts for easy identification, when the screws are removed.

- (1) Shift the knob (51) of the accessory cover (50) in the arrow direction, and remove the cover.
- (2) Extract the auto motif dial (52) upward.
- (3) Extract the card feed dial (53), the spring and the gear.
- (4) Unscrew six clamp screws (four long ones and two short ones) on the pattern board.
- (5) Lift the fastening portion (centre) of the pattern boards 1, 2, and remove the shaft. Then, shift the pattern board (54) in the arrow direction to remove it from the case, left (55), and shift the pattern board (56) in the directions of (a) and (B) in such a sequence to remove it from the case, right (57). (Fig.-36, Fig.-37)
- (6) Unscrew four clamp screws on the needle beds (58), right and left. (Fig.-37)
- (7) Open the right and left rings (60) of the case handle (59), using a plier with a cloth put on, and remove the rings.
- (8) Unscrew the clamp screw (61). (Fig.-38)

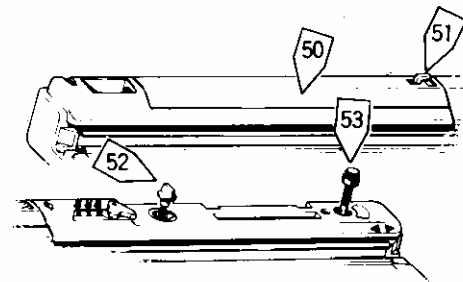

Fig.-35

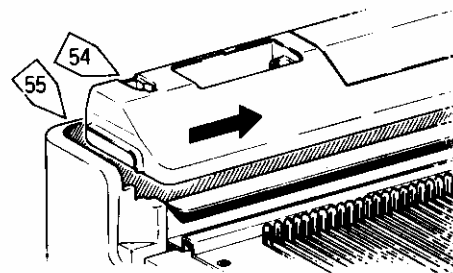

Fig.-36

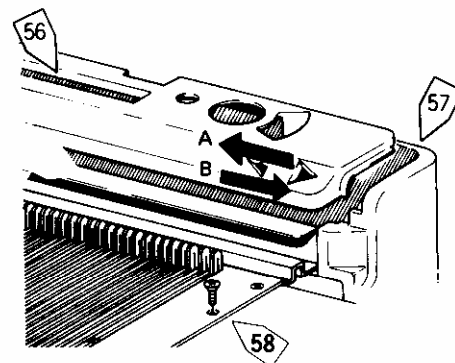

Fig.-37

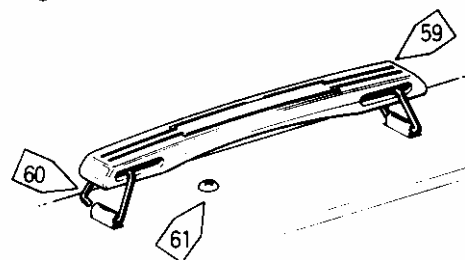

Fig.-38

- (9) Set the back side of the knitting machine body up.

Unscrew four clamp screws on the clamp supporter bases (62), right and left, and unscrew the clamp screw (63) on the right side. After that, turn the front side up, and shift the convex of the carriage handle base plate to the inside of the case. Then, while shifting the needle bed leftward, lift and pull out the needle bed forward. (Fig.-39, Fig.-40)

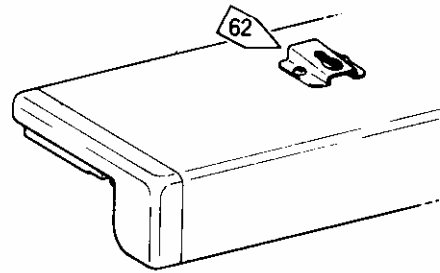

Fig.-39

- (10) Unscrew two clamp screws (64) on the right side of the needle bed (58). (Fig.-41)

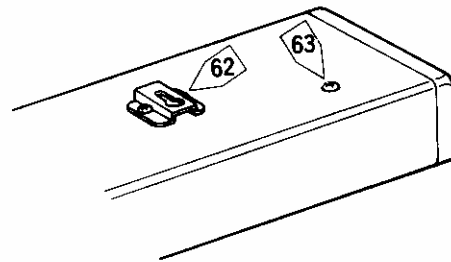

Fig.-40

- (11) Turn the back side of the needle bed up as illustrated in Fig.-42, and place pillows at both ends of the needle bed. Then, scribe lines on the installing portion of the needle bed connecting plates (69) (70), the knit tracer base plate (68) and the jacquard base plate (71).

Unscrew six clamp screws for fastening the knit tracer base plate (68) and the needle bed connecting plates (69) (70), and remove the knit tracer base plate.

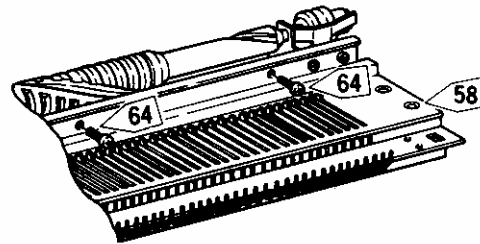

Fig.-41

- (12) Unscrew seven clamp screws for fastening the jacquard base plate (71), the selection plate guide (72) and the needle bed connecting plates (69) (70), and remove the selection plate guide (65). Then, turn the front side of the needle bed up, and remove the jacquard base plate from the needle bed.

\* Since adjusting shims are inserted between the needle bed connecting plates (69) (70), the jacquard base plate (71) and the selection plate holder, never mistake the number and positions of the shims at the time of assembly.

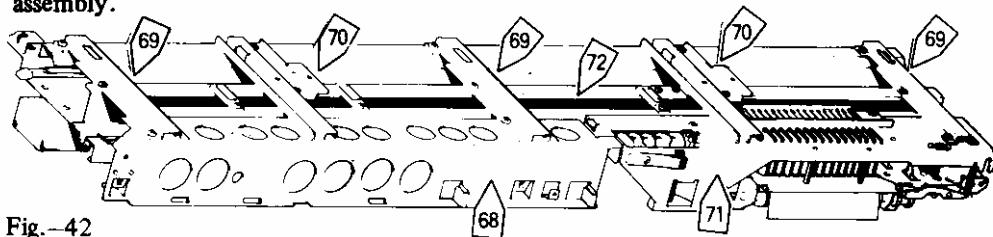

Fig.-42

- (13) Unscrew two clamp screws which install the spring holder (73) and the selection plate holder (72). (Fig.-43)

\* Never unscrew the other screws.

- (14) Unscrew the clamp screw on the selection pin stopper (74), and separate the selection plate holder and the jacquard base plate (71) slowly in the crosswise direction. (Fig.-44)

- (15) Eight selection plates (77), five auto motif plates (78) and eight selection pin connecting plates (79) have been set on the selection plate holder ass'y (72). When it is required to replace the selection plate, etc., replace the selection plate holder ass'y without the selection pin connecting plate (79). (Fig.-45)

\* Setting procedure of selection pin connecting plate

Put the selection pin connecting plates side by side from No.1, in the sequence that the inserting hole (a) of the selection pin 2 is shifted leftward by 1 pitch, to No.8. Then, insert the selection pin connecting plate into the groove of the selection plate pin, shift it in the arrow direction, and insert it into the groove of the partition.

(Fig.-46)

#### CONFIRMATION

- (1) The selection plate and the auto motif plate should operate lightly (approx. 20 g).
- (2) When the operation of the said plates is heavy, check if the slant groove of the selection plate partition is damaged. (Replace the parts.)
- (3) Check if the projections of the selection plate and the auto motif plate are damaged.
- (4) Confirm if the selection pin connecting plate (79) is disengaged from the partition plate or the like.

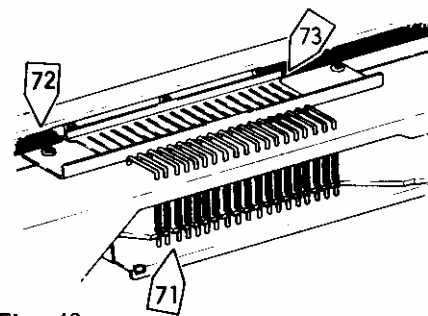

Fig.-43

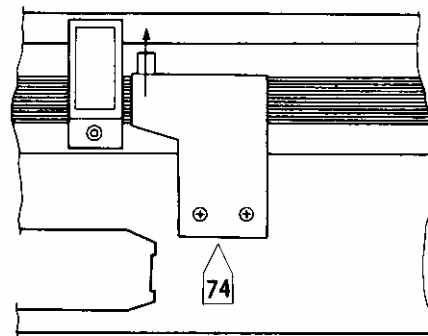

Fig.-44

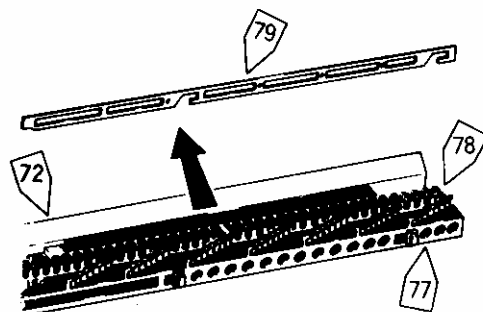

Fig.-45

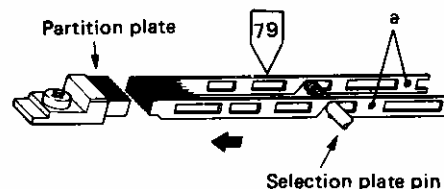

Fig.-46

## INSTALLATION

- (1) Install the selection plate holder ass'y (72) and the jacquard base plate (71) in the following procedure. (Fig.-48)
- (2) Extract the selection pins 3 (80) and the dial shaft (81) from the jacquard base plate (71). Use care not to bounce the springs (82) (83). (Fig.-47)
- (3) Insert 24 selection pin 2 (84) into the fitting holes of the selection pin connecting plate (79).
  - Shift the selection pin 2 leftward.
  - With the selection pin connecting plate located at the position 2 to 3 mm returned rightward, place the magnet at the position shown in Fig.-49, and fix the selection pin connecting plate.
  - Shift the jacquard base plate to the selection plate holder side. Position 24 selection pins 2 inside the selection pin connecting plate guide, using SST3. (Fig.-50)
  - Moving the jacquard base plate in the crosswise direction, fit the selection pins into the connecting plates in sequence.

After confirming that the pins have been inserted into the eight connecting plates, remove SST3 and the magnet.

  - When operating the selection pins 2 one by one from the right side, the selection pin connecting plate should be operated one by one, and the selection pin 2 should also be operated interlocked with the eighth selection pin.
- (4) Install the panel holder (73) and the selection plate holder (74), using two clamp screws. (Fig.-51)

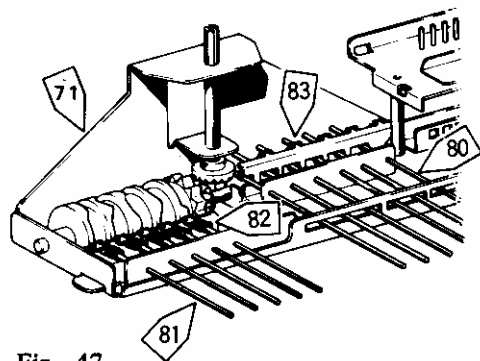

Fig.-47

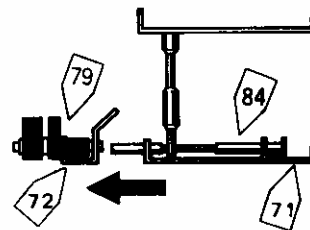

Fig.-48

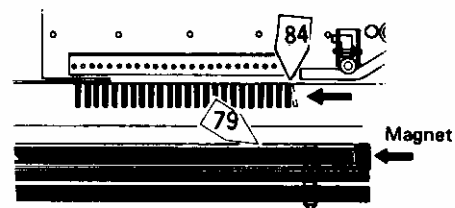

Fig.-49

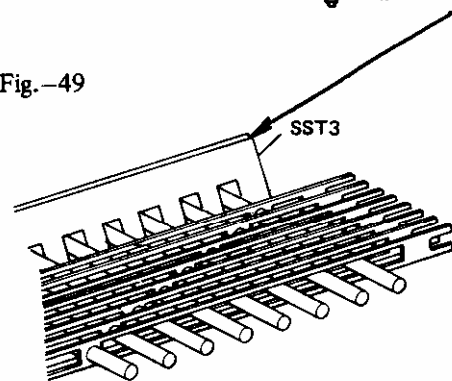

Fig.-50

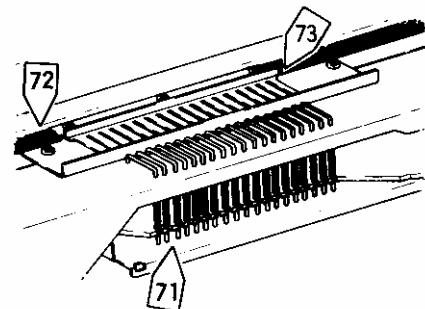

Fig.-51

(5) In order to make it easy to pass the auto motif pin and the selection pin 3 into the auto motif plate and the selection plate, position the plates, using SST4. (Fig.-52)

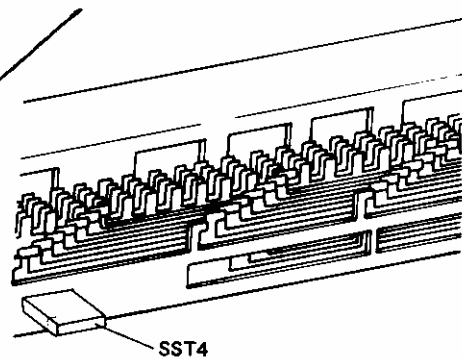

Fig.-52

(6) Insert the auto motif pin (81) (shorter one) into the inserting hole of the auto motif plate. Pass the spring (82) into the auto motif pin. Then, hook the other hook spring at the hook of the needle, and hook the spring at the guide of the auto motif inserting plate. Set five springs in this manner. (Fig.-53)

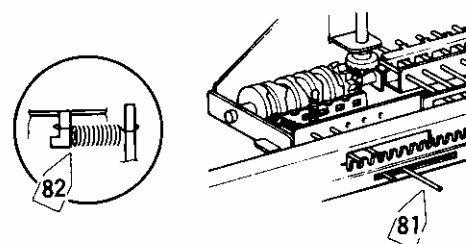

Fig.-53

(7) Pass the selection pins 3 (80) into the selection plate (77), the selection pin connecting plate (78) and the selection pin fulcrum (85). Then, after passing the hooked portion of the spring (83) into the selection pin 3, slide the pin to the innermost position. Using the hooked portion of the needle, hook one end of the hook at the guide. Set eight springs in this manner. (Fig.-54)

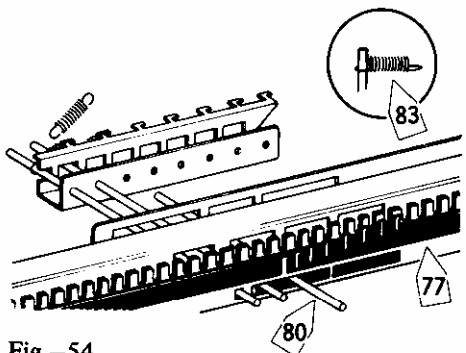

Fig.-54

**CONFIRMATION**

- Moving the auto motif pin, check if the movement of the auto motif plate and the auto motif pin is satisfactory.
- Moving the selection pin 3, check if the movement of the selection plate and the selection pin 3 is satisfactory.

(8) Install the selection pin stopper (74), and extract only two selection pins at both ends of 24 selection pins 1 (86). Then, insert two pins of SST7 into the inserting holes of the selection pin 1, and press Portion "b" of the selection pin stopper against portion "a" of SST7. Then, fasten the clamp screw so that the selection pin stopper is not tilted. (Fig.-55)

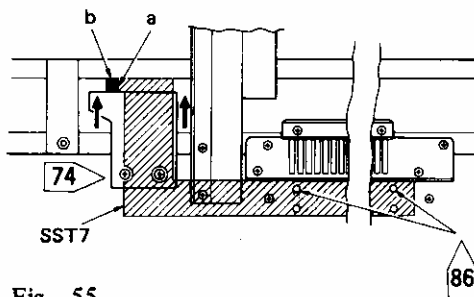

Fig.-55

- (9) Set the needle bed (53) with its front side up, and set the jacquard base plate ass'y (75) on the needle bed.

· Set portion "a" of the jacquard base plate to groove of portion "b" of the needle selection base drum (87), and join them.

· At this time, the shaft of the selection pin stopper (74) is inserted into the selection pin stopper hole of the needle bed, and thus the positions of the needle bed and the jacquard base plate are fixed.

(Fig.-57)

- (10) Temporarily fasten the screw (64) for clamping the jacquard base plate and the needle bed. (Fig.-58)
- (11) Setting the needle bed with its back side up, install the jacquard base plate and the selection plate holder on the needle bed connecting plates (69) (70).

\*Otherwise the height of needle selection base drum presser plate will be wrong. (Fig.-58A)

- (12) After fixing the jacquard base plate temporarily, check the height of needle selection base drum presser plate using SST-5-1. If each of the clearance at portion c and d is 0.1 mm or less, fasten the screw (64) firmly. (Fig.-58A)
- (13) After setting the lower side frame (68) to the scribed line, install it. (Fig.-59)

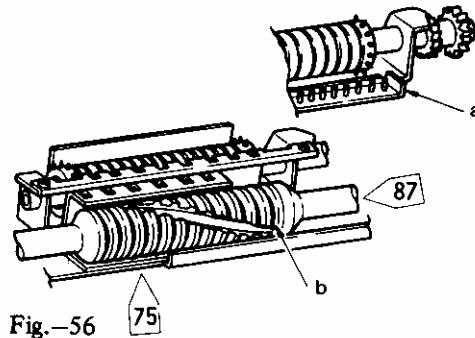

Fig.-56

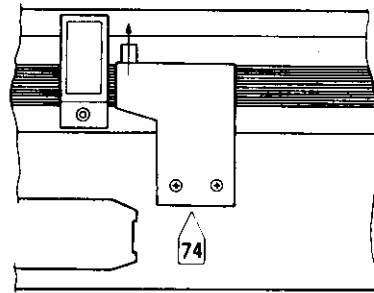

Fig.-57

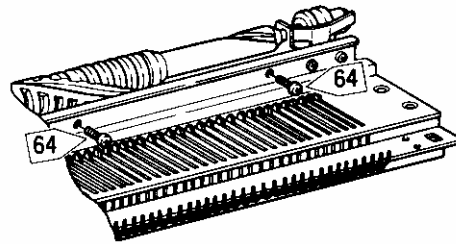

Fig.-58

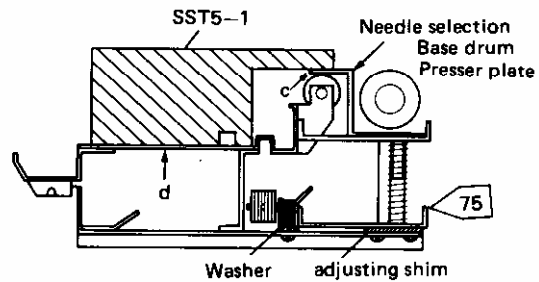

Fig.-58A

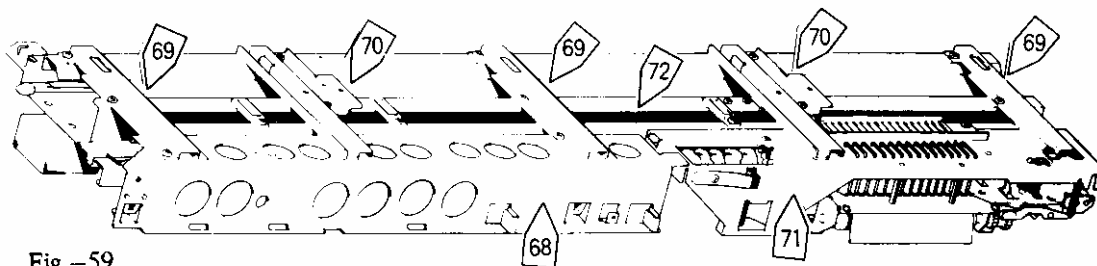

Fig.-59

After the above assembling procedure, check as described below, and if there is nothing abnormal, install the case.

- Fit the carriage ass'y on the needle bed, and set the card lever of the carriage at position C.
- Bring out the latch needle from position A to position B, and slide the carriage. It is normal if all the needles at position B are selected to position D.
- Then, set the punch card for 1/1 needle selection (No.1), and slide the carriage. It is normal if the card is fed one by one and if the needles are selected according to the pattern on the card.
- Then, rotate the auto motif dial in turn and confirm that the needles are selected properly to the auto motif positions.

- (14) To install the needle bed ass'y on the lower case, install in the reverse procedure of removal.

### VI-13 Replacement of Jacquard Base Plate

#### REMOVAL

- (1) Referring to VI-12, remove up to the selection plate holder and the jacquard base plate. Extract the selection pin 3 and the auto motif pin also, and remove each spring.
- (2) Extract 24 selection pins 2 (80).
- (3) Unscrew two clamp screws on the spring holder (73), and extract 24 selection pin operating rods (93). (Fig.-62)
- (4) Extract the selection pins 1 (94) from the jacquard base plate as shown in (Fig.-63)

If they cannot be extracted, remove the E rings (95) and extract them using care not to bounce the springs.

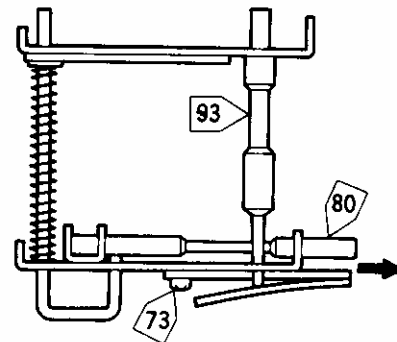

Fig.-62

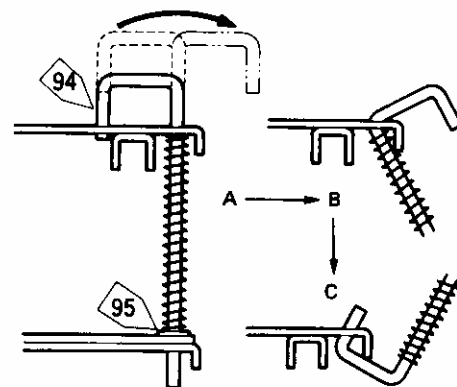

Fig.-63

- (5) Unscrew the clamp screw on the card drum (96), and remove the drum. (Fig.-64)

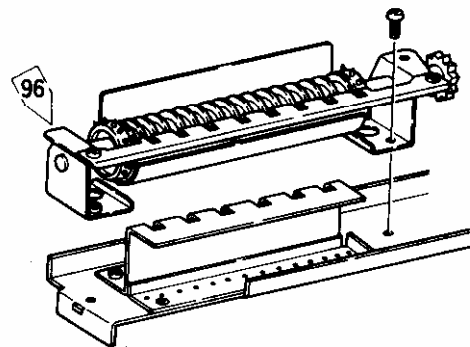

Fig.-64



- (6) Unscrew the clamp screw on the jacquard link roller base (97). Setting portion "a" of the jacquard link roller base to the cut groove of the jacquard base plate, remove it upward. (Fig.-65)
- (7) Remove the E rings (99) on the jacquard links 1 (98), and remove the jacquard link 1. (Fig.-65)
- (8) Remove the card ratchet return spring (100). (Fig.-65)
- (9) Pressing portion "b" of the card ratchet (101), shift it in the forward direction. Then, set portion "c" to the cut groove of the jacquard base plate, remove it upward. (Fig.-65)
- (10) Remove the E ring on the direction indicator (102), and remove the direction indicator. (Fig.-65)
- (11) Unscrew the clamp screw on the snap spring (102), and remove the snap spring.
- (12) Remove the stop lever spring (103).
- (13) Remove the E ring (105) on the card positioning pin (104), and remove the card positioning pin and the spring. (Fig.-66)

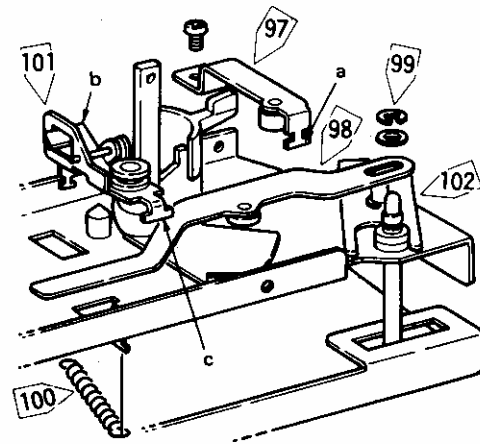

Fig.-65

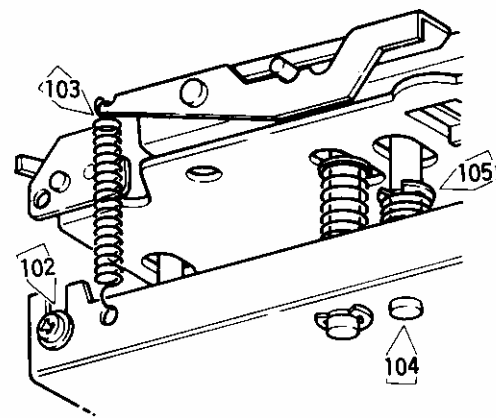

Fig.-66

When it is required to replace the jacquard base plate ass'y, remove the parts as described above, and never remove the parts except these.

In particular, never loosen or change the positions of the connecting screws for the jacquard base plate 1 (lower part) and the upper part of the jacquard base plate 2, and the clamp screws for the selection pin fulcrum and the magic motif adjusting plate, etc. (Fig.-66A)

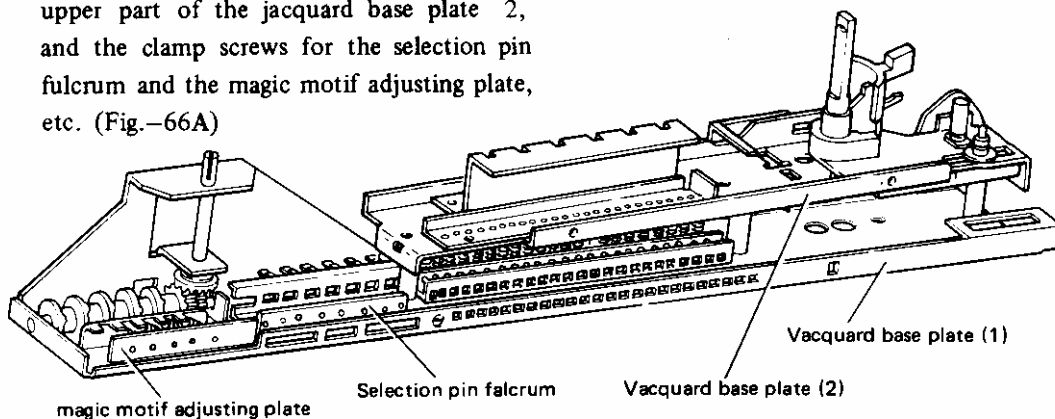

Fig.-66A

## ASSEMBLY

- (1) Insert the direction indicator (102) into the shaft, and clamp it with the E ring (106). (Fig.-67)
- (2) Pass the card positioning pin (104) into the jacquard base plate, and insert the spring. Then, clamp with the E ring (105). (Fig.-68)
- (3) Hook the stop lever spring (103). (Fig.-68)
- (4) Bring out the snap spring (112) to the outside of the shaft (107), and install it.
- (5) Insert the card ratchet (101) into the installing position. (Fig.-69)
- (6) Put the jacquard link (98) into the shaft, and clamp it with the E ring. (Fig.-69)

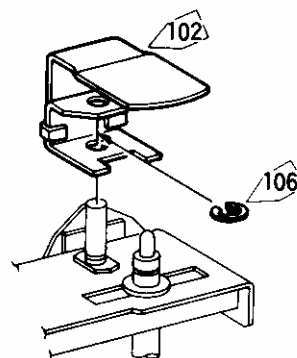

Fig.-67

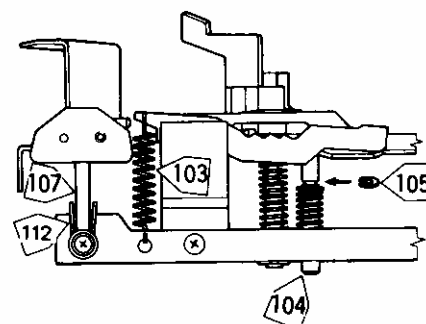

Fig.-68

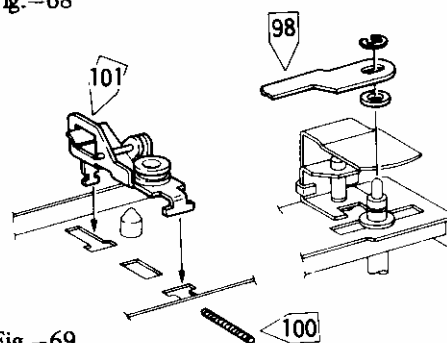

Fig.-69

- (7) Place the jacquard link roller (97) at the installing position, and install it with clearance of 0.5 mm provided between the jacquard base plate and the jacquard link roller. (Fig.-70)

\* After assembling the card drum shaft, set the card and rotate the needle selection base drum. Then, confirm if the card is fed by 1 pitch surely.

If the card fails to be fed properly, adjust the position of the jacquard link roller in the back and forth direction.

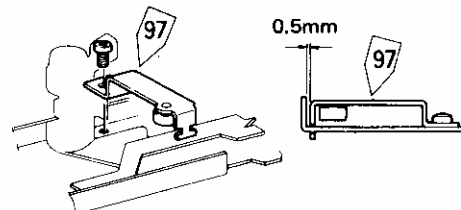

Fig.-70

- (8) Insert the selection pins 1 (95) into the jacquard base plate. (Fig.-71)

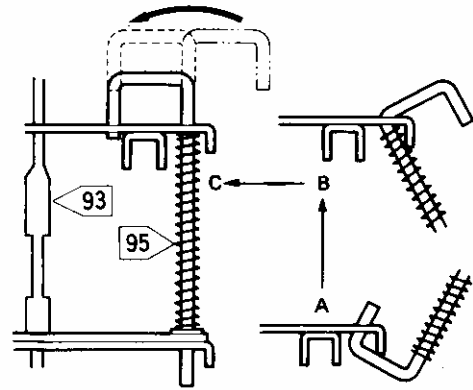

Fig.-71

- (9) Insert the selection pin operating rod into the jacquard base plate, and temporarily fasten the spring holder (73) using two clamp screws. Then, insert SST8 into the positioning hole, and fasten the screws. (Fig.-72)

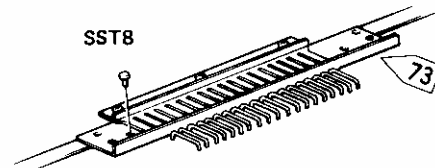

Fig.-72

- (10) Temporarily fasten the card drum shaft (96) using two clamp screws. Pass SST6 into the jacquard base plate, through the positioning hole of the card drum shaft (insert two SST's into the right and left plates). Then, fasten the screws and remove SST6. (Fig.-73)

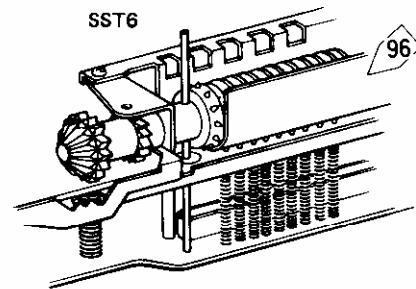

Fig.-73

- (11) Refer to the assembling procedure of the selection plate holder for the assembling procedure of the jacquard base plate complete and the selection plate holder and thereafter. (VI-12)

## VI-14 Replacement of Needle Retaining Spring

### REMOVAL

- (1) Referring to (1) ~ (9) in VI-12, remove the needle bed from the lower case.
- (2) Turn the back side of the needle bed up, and unscrew 13 clamp screws on the needle retaining spring, large (108) and small (109) and the needle guide plate (110). Then, lift the ends (A) of the needle retaining springs (large and small) only, slide them in the lateral direction, and extract them from the needle bed. Leave the needle guide plate dropped between the latch needles. (Fig.-75, Fig.-76)

### INSTALLATION

- (1) Confirm, looking at the position of the screw hole, if the needle guide plate is properly set at the installing position.
- (2) Spread the needle bed protection film (111) on the needle. Join the needle retaining spring (large) with the needle retaining spring (small), and while sliding them on the protection film from the side of the needle bed, place them on the installing position, and remove the protection film. (Fig.-77)
- (3) Align the screw holes of the needle guide plate and two needle retaining springs (large and small), and temporarily fasten them at right and left ends.
- (4) Hold the end of the needle guide plate, and shifting it in the crosswise direction, set the needle groove of the needle bed to the groove centre of the guide plate (to the position where the latch needle moves lightly). (Fig.-78)
- (5) Adjust until the needle retaining springs (large and small) are located at the centre of the latch needle. Then, holding the needle guide plate and the needle retaining spring in place, fasten the clamp screw, and fasten the other clamp screws.
- (6) Referring to (1) ~ (9) in VI-12 INSTALLATION, install the other parts.

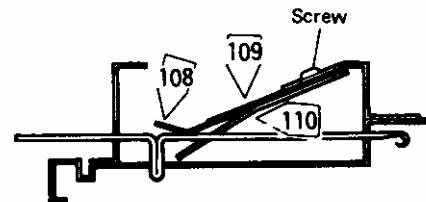

Fig.-75

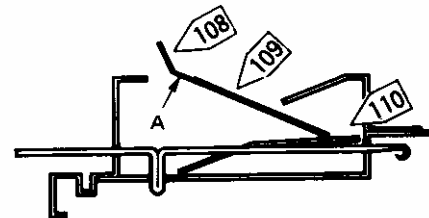

Fig.-76

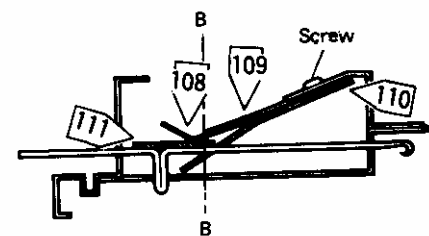
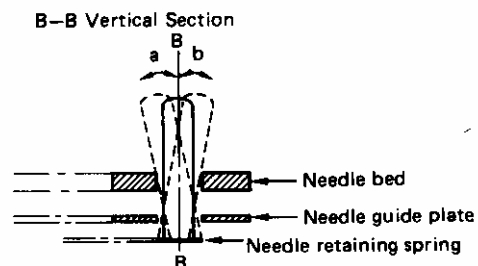

Fig.-77



Lean of the latch needle should be equal in both sides, a and b.

Fig.-78