

**Genie**

"the magic knitter"

MODEL CH-1500

# SUPPLEMENTARY INSTRUCTION BOOK

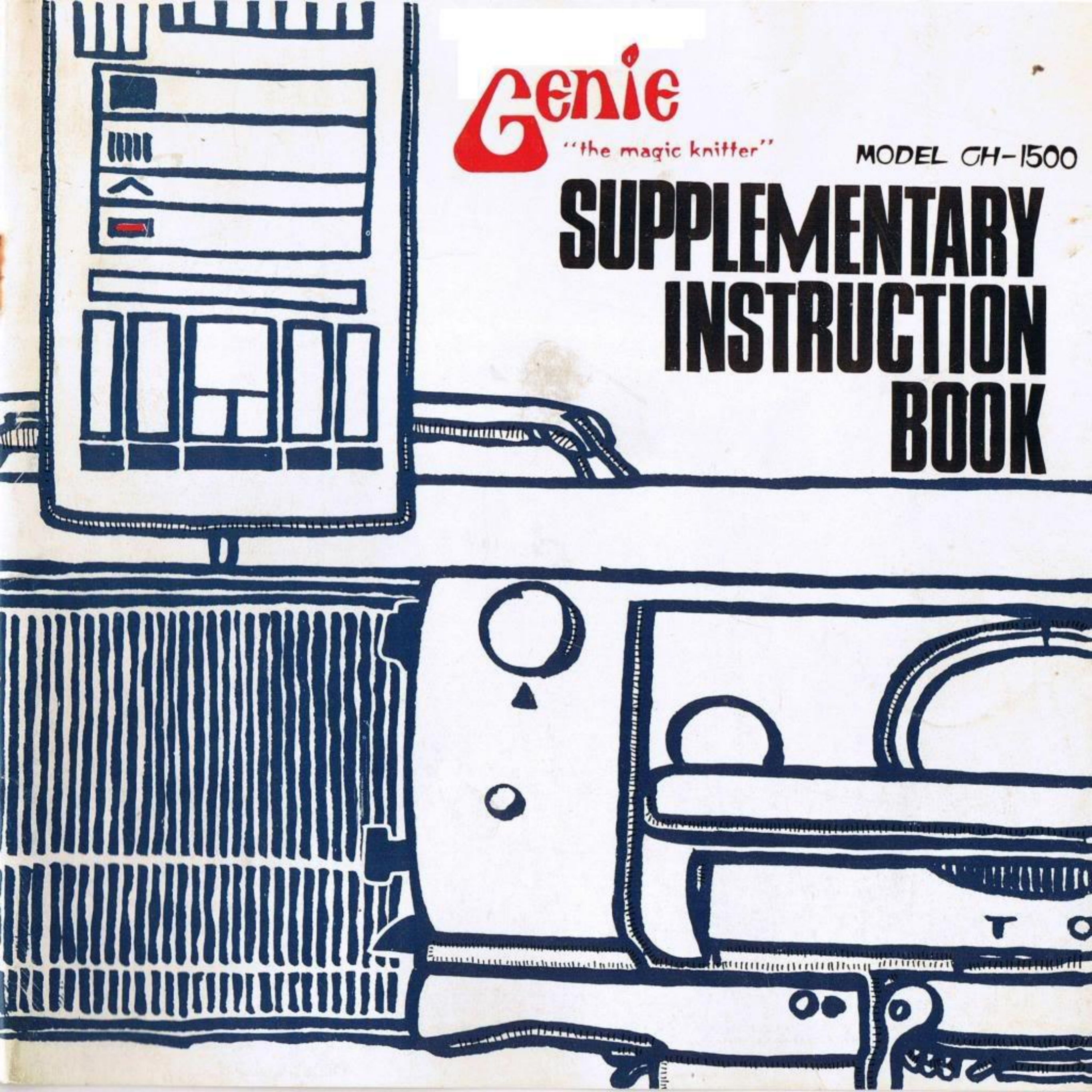

---

This Supplement contains Instructions for  
Advanced Pattern Knitting.

The scope of the Model CH-1500 Knitting Machine in the field of Fancy Pattern Knitting is far greater than that of any other Domestic Knitting Machine. The Model CH-1500 offers unlimited opportunities to the advanced knitter with a flair for designing.

---

---

## EXPLANATION OF NEEDLE AND SINKER ACTION

The machine has 200 latch needles in the needle bed and each stitch is formed by the latch needles operating in conjunction with the movement of the carriage.

Below you will find an illustration of a latch needle and the names of its various parts, (Fig. 1) and also a description of how the stitches are formed by the latch needles and the special sinkers. (Fig. 2)

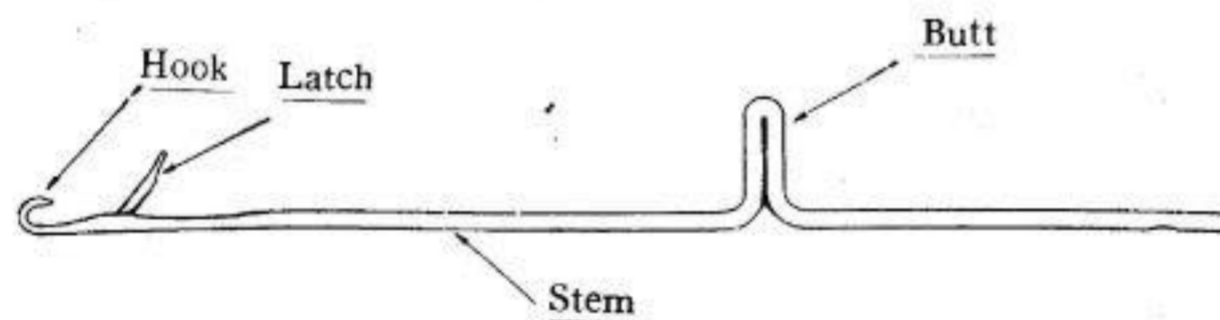

Fig. 1

- 
1. A stitch is held on the open latch by the sinker. (Fig. 2-1)
  2. The needle moves forward and the stitch passes behind the latch. (Fig. 2-2)
  3. As the needle moves back, new wool is fed into the hook and the previous stitch closes the latch. (Fig. 2-3)
  4. As the needle continues to move back, the sinker moves forward and the front of the sinker pushes the previous stitch over the closed latch to form a new stitch. (Fig. 2-4)
  5. The sinker now moves back and the sinker hook engages with the strand of wool between the stitches. (Fig. 2-5)
  6. The sinker continues to move back and downwards and at the same time the needle moves forward so that the new stitch opens the latch ready to commence forming yet another stitch. (Fig. 2-6)

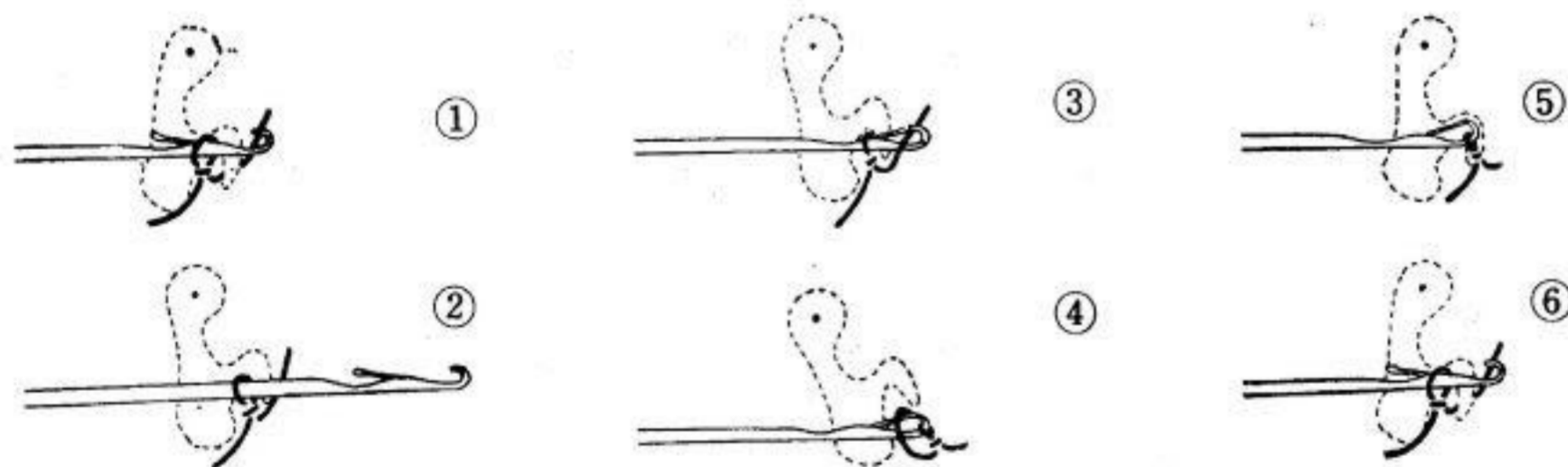

Fig. 2 — 1, 2, 3, 4, 5 & 6.

## NEEDLE POSITIONS

**NOTE:** Positions of the needles herein referred to are positions of the butts of the needles.  
(Fig. 3)

**(A) Rest Position** (Non-working position)

Needles not in use. The needles when not in use should always be pushed back against the Needle Selection Guide Strip.

**(B) Automatic Selection Position**

Needle or needles are pushed back to this position from Working Position (C) when selected for automatic pattern making.

**(C) Working Position**

The required number of needles for knitting should be brought forward from position (A) into this position before commencing to knit.

**(D) Manual Return from Holding Position**

Needles will knit when pushed back into this position from the Holding Position (E).

**(E) Holding Position**

Needles hold stitches but do not knit when in this position -- used for manually operated Fair Isle, Tucking stitches, etc., also for "V" neck opening, turnings, etc. The needles in the Position (C) are automatically forwarded into this Position (E) when moving the carriage and at the same time pushing in the leading Needle Forwarding Lever.

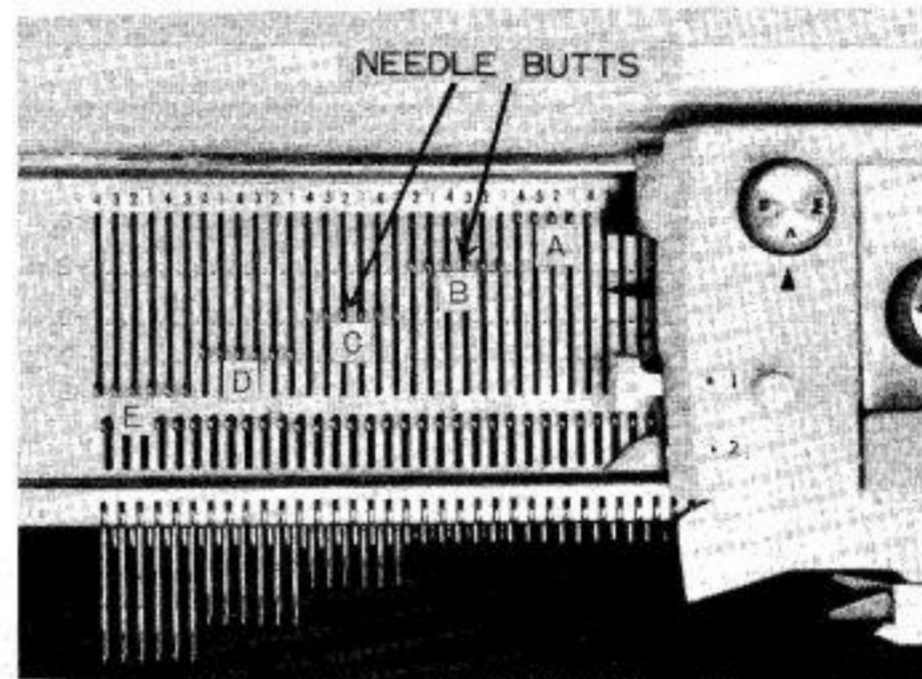

Fig. 3

---

## THE AUTOMATIC ROW COUNTER

1. The Row Counter automatically counts the rows as the carriage is moved from side to side with the Row Counter Trip Arm extended. (Figs. 4&5)
2. The Row Counter registers single units on the right, tens in the centre and hundreds on the left. It counts automatically up to 999. (Fig. 6)
3. The numbers on the Row Counter may be adjusted or returned to zero by turning the adjusting screws on the back of the Counter. (Fig. 6)

To obtain numbers 000 on the Row Counter, turn the adjusting screw for the single units at first so that it registers 0 for the single units, then proceed for tens units and hundreds units in order.

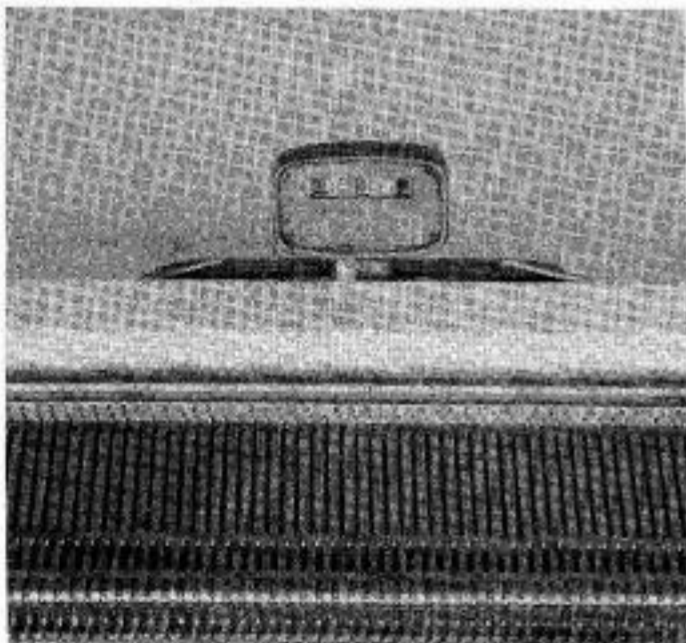

Fig. 4

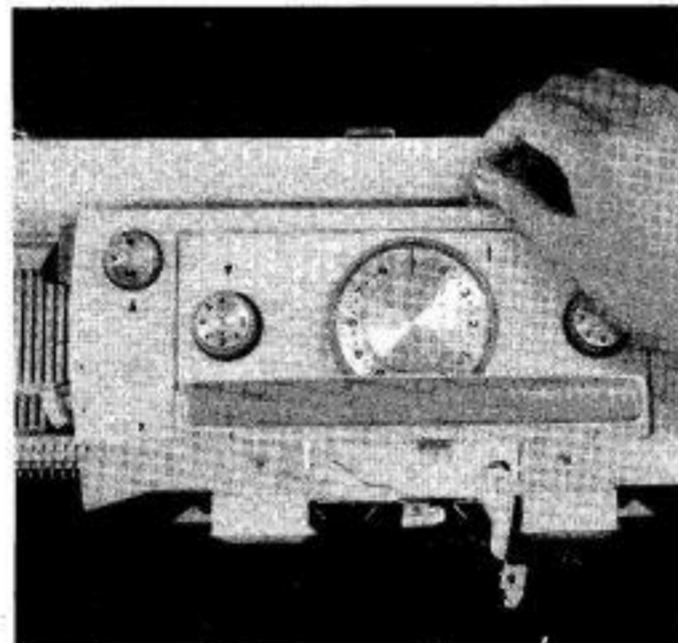

Fig. 5

Place of:  
One Ten Hundred

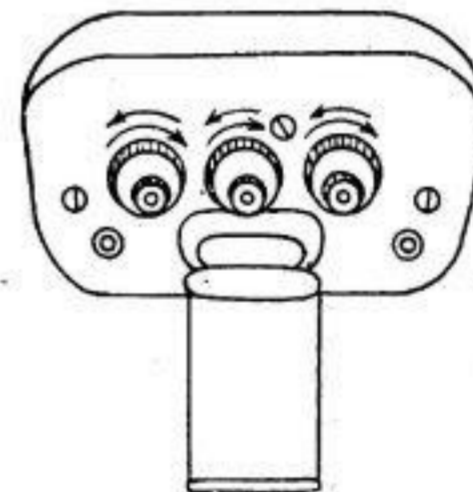

Fig. 6

---

## TENSION CONTROL DIAL

This controls the size of the stitch; the higher numbers giving the looser tension. The following table and illustrations (Fig. 7) give approximate settings for various thicknesses of yarn.

0 — 3	Very fine yarns
3 — 6	Medium yarns
6 — 9	Heavy yarns
8 — 10	Very heavy yarns

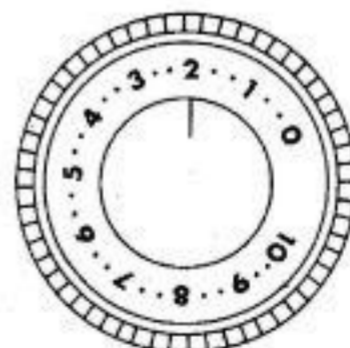
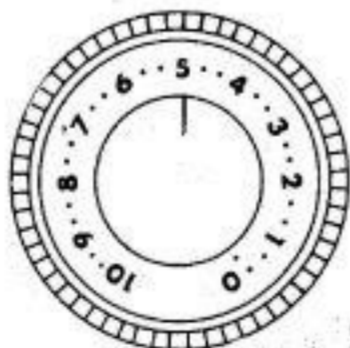
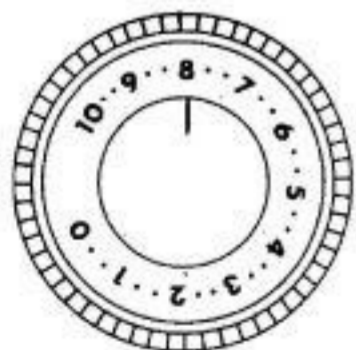
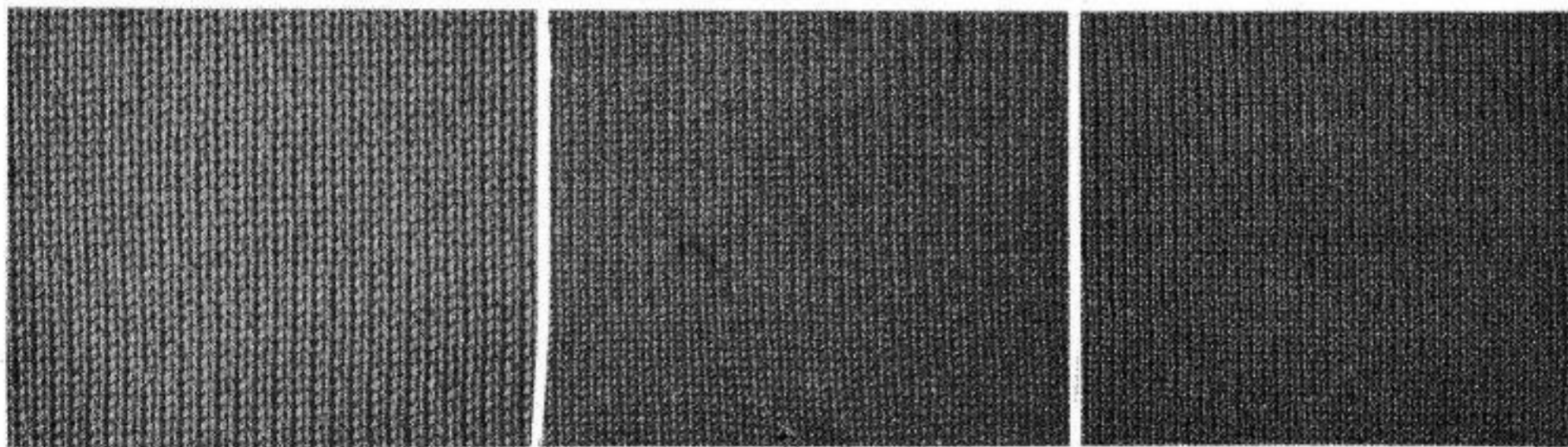

Fig. 7

When knitting heavy yarns such as Double Knitting Wool use every alternate needle or, in the case of bulky or extra thick Double Knitting Wool, use every third needle, and cast-on by the Manual Method.

---

## THE CARRIAGE

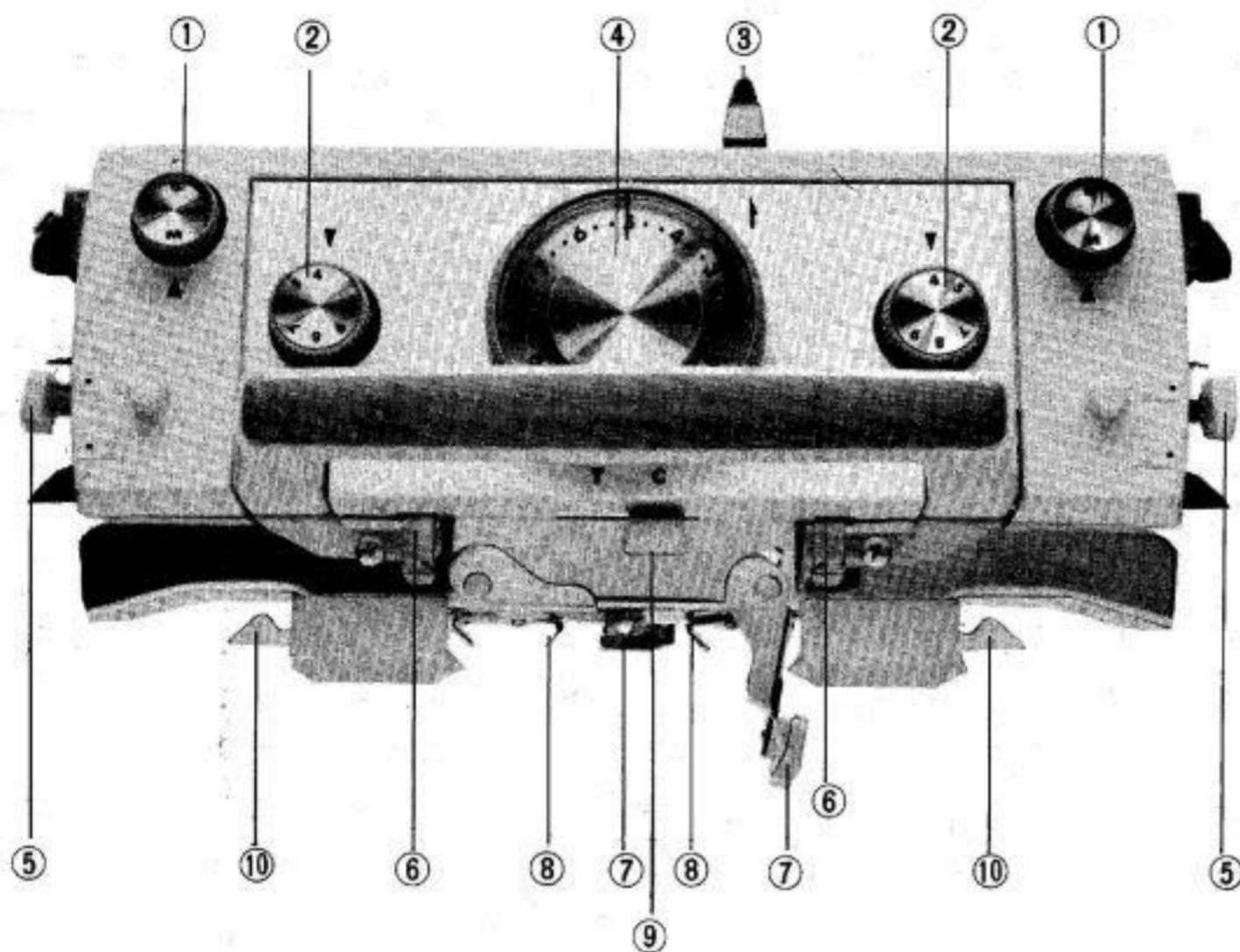

Fig. 8

- |                                       |                                    |
|---------------------------------------|------------------------------------|
| 1. Pattern Control Knobs (MAS Knobs). | 6. Needle Forwarding Levers.       |
| 2. Needle Selection Control Knobs.    | 7. Yarn Feeders.                   |
| 3. Row Counter Trip Arm.              | 8. Subsidiary Yarn Feeders.        |
| 4. Tension Control Dial.              | 9. Shifting Cam Lever (T-C Lever). |
| 5. Return Cam Levers.                 | 10. Weaving Feeders.               |



## 1. PATTERN CONTROL KNOBS (MAS Knobs) — (Fig. 8—1)

These Knobs control the Needle Guide Cam.

### 'M' opposite pointer: —

With the knobs in this setting you will see the tip of the Needle Guide Cam protruding beyond the end of the carriage and pointing towards the needles in the Non-Working Position (A).

(Figs. 9A & 9B)

This means that needles in any of the Positions (B), (C) or (D) — (see Fig. 3) — will knit, and further when setting the Return Cam Lever to No. 2, needles in Position (E) will also knit. (Fig. 9B)

The Pattern Control Knobs should be at setting 'M' when knitting in plain stocking stitch.

### 'A' opposite pointer: —

If you turn the knobs so that 'A' is now opposite the pointer (Fig. 10A), you will notice that the tip of the Needle Guide Cam is extended at right angles to the carriage end and midway between Position (B) and (C) of the needles. (Fig. 10B)

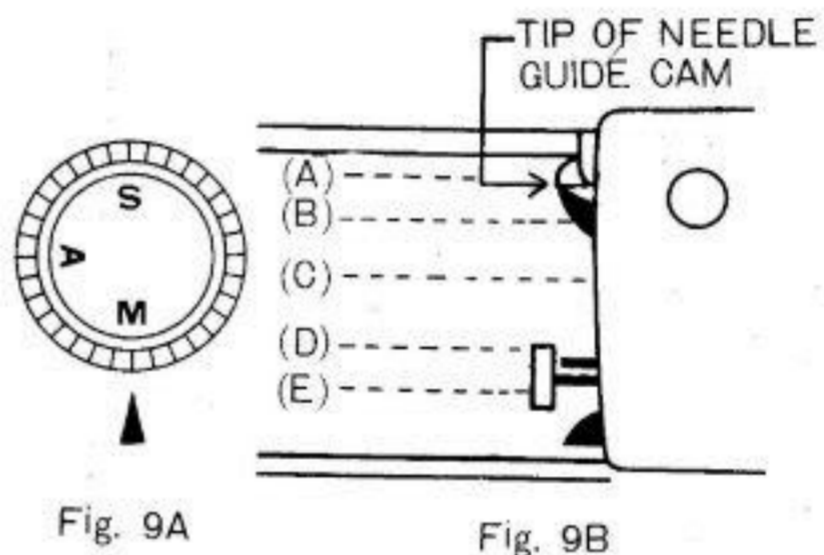

Fig. 9A

Fig. 9B

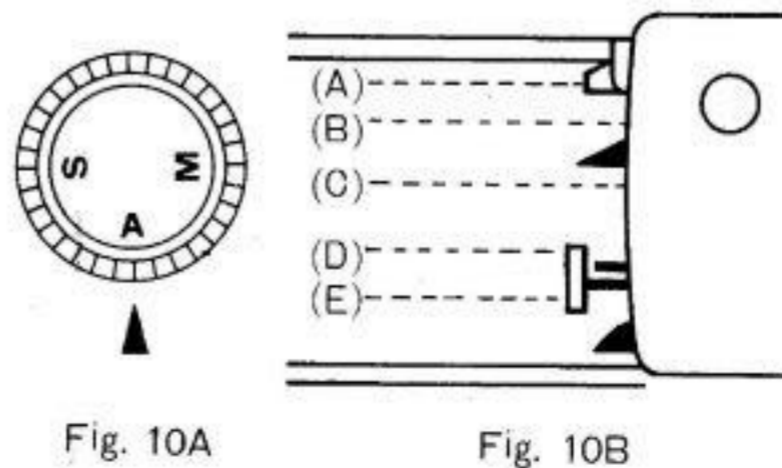

Fig. 10A

Fig. 10B

---

The Pattern Control Knobs in this position are set for AUTOMATIC SELECTION of needles. In order to illustrate what the function of the Automatic Selector is—

- (1) Turn the Needle Selection Control Knobs so that 4 is opposite the pointer.
- (2) Bring forward into Working Position (C) and in the centre of the machine some 40 needles.
- (3) Ensure that all the needle butts are in a straight line and you will observe that when in The Working Position (C) the needle butts are forward of the tip of the Needle Guide Cam.
- (4) With the carriage on the right push back into Position (B) the 2nd and 4th needles on the right as shown in Fig. 11. You will see that the butts of the 2 needles in Position (B) are now behind the tip of the Needle Guide Cam.
- (5) When the carriage is moved across the working needles you will note the following—
  - a) **With the Shifting Cam Lever (TC Lever) at "C"** half the needles, in alternate formation, will knit whilst the others will hold the stitches.
  - b) **With the Shifting Cam Lever (TC Lever) at "T"** half the needles, in alternate formation, will knit whilst the others will come forward and pick up a strand of wool but will not knit the previous stitch. The function of the needles under sub-para (b) is used for "tucking" patterns.

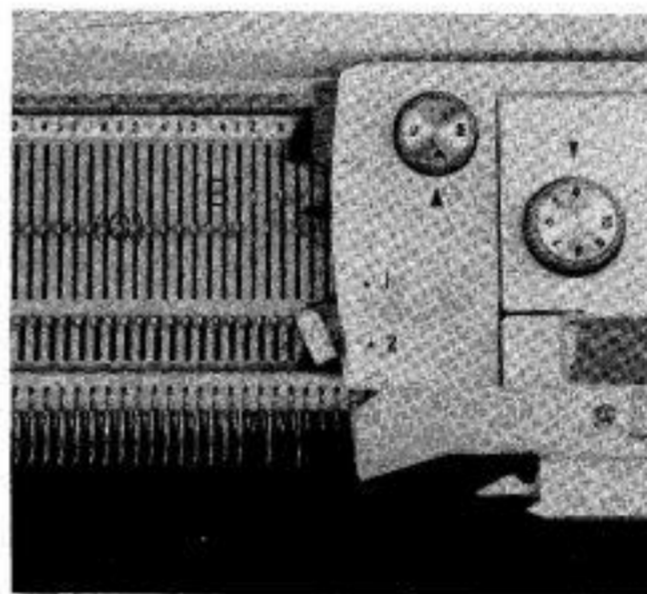

Fig. 11

**'S' opposite pointer : —**

Turn the knobs so that 'S' is opposite the pointer (Fig. 12A), and you will notice that the tip of the Needle Guide Cam is now pointing towards the front of the machine and is forward of the needles in Working Position (C). (Fig. 12B)

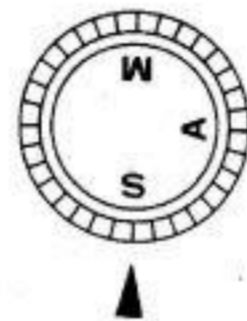

Fig. 12A

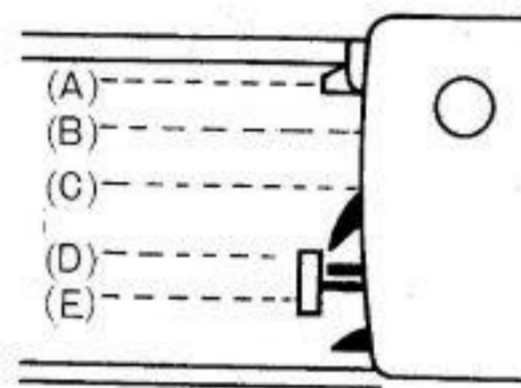

Fig. 12B

Needles in Position (B) and (C) will therefore not knit when the carriage is moved across them with the Pattern Control Knobs in this position. The

Knobs should therefore only be at this setting 'S' when—

- (a) you require to move the carriage from one end of the machine to the other and across working needles without affecting the knitting on the needles e. g. to introduce a different colour strand of wool at the opposite end.
- (b) you wish to produce intricate multicoloured effects manually, knitting only on needles in the Holding Position (E).

---

## 2. NEEDLE SELECTION CONTROL KNOBS (Fig. 8-2)

These Control Knobs are marked with figures 4, 5, 6, 7, 8, 9 and 10, and **to turn, first depress the knob.** Selection of needles is made with the forefinger by pushing back the required number of needles from Working Position (C) into Position (B). When using these knobs the Pattern Control Knobs (MAS Knobs)—(Fig. 8-1) must always be set at "A".

With the Needle Selection Control Knobs set at —

- No. 4. needles may be selected in combinations of 4, i.e. 1 and 3, 3 and 1, 2 and 2, 1 and 1.
- No. 5. needles may be selected in combinations of 5, i.e. 1 and 4, 4 and 1, 2 and 3, 3 and 2.
- No. 6. needles may be selected in combinations of 6, i.e. 1 and 1, 3 and 3, 2 and 4, 1 and 5, 2 and 2.
- No. 7. needles may be selected in combinations of 7, i.e. 1 and 6, 2 and 5, 3 and 4.
- No. 8. needles may be selected in combinations of 8, i.e. 1 and 1, 2 and 2, 2 and 6, 3 and 5, 4 and 4.
- No. 9. needles may be selected in combinations of 9, i.e. 1 and 8, 2 and 7, 3 and 6, 4 and 5, 3 and 3.
- No. 10. needles may be selected in combinations of 10, i.e. 1 and 9, 2 and 8, 3 and 7, 4 and 6, 5 and 5, 1 and 1, 2 and 2.

### \* How To Vary the Selection Of Needles When Using The 7 Basic Combinations.

#### 4, 5, 6, 7, 8, 9 and 10

Draw forward from the Needle Rest Position (A) into the Working Position (C) 60 needles.

Turn both Pattern Control Knobs to 'A'.

Next, push **only** the 1st needle back from the Working Position (C) into Position (B). The remaining needles in Working Position (C) will function as follows when the carriage is moved across them.

With Needle Selection		With Shifting		Function of	
Control Knobs at:		Cam Lever at:		Needles:	
No. 4	•••••	•••••	C	•••••	Knit 3 Hold 1
No. 4	•••••	•••••	T	•••••	Knit 3 Tuck 1
No. 5	•••••	•••••	C	•••••	Knit 4 Hold 1
No. 5	•••••	•••••	T	•••••	Knit 4 Tuck 1
No. 6	•••••	•••••	C	•••••	Knit 5 Hold 1
No. 6	•••••	•••••	T	•••••	Knit 5 Tuck 1
No. 7	•••••	•••••	C	•••••	Knit 6 Hold 1
No. 7	•••••	•••••	T	•••••	Knit 6 Tuck 1
No. 8	•••••	•••••	C	•••••	Knit 7 Hold 1
No. 8	•••••	•••••	T	•••••	Knit 7 Tuck 1
No. 9	•••••	•••••	C	•••••	Knit 8 Hold 1
No. 9	•••••	•••••	T	•••••	Knit 8 Tuck 1
No. 10	•••••	•••••	C	•••••	Knit 9 Hold 1
No. 10	•••••	•••••	T	•••••	Knit 9 Tuck 1

Each of these seven basic combinations can be varied according to the number of needles selected at the commencement of a row.

---

**\* Tables Of Needle Combinations — (Automatic Needle Selection)**

The following tables set out on pages 15, 16, 17, 18, 19, 20 & 21 show you how to obtain a wide variety of needle formations automatically—

- Table 1** Combinations obtainable when the Needle Selection Control Knobs are set at 4.  
**Table 2** Combinations obtainable when the Needle Selection Control Knobs are set at 5.  
**Table 3** Combinations obtainable when the Needle Selection Control Knobs are set at 6.  
**Table 4** Combinations obtainable when the Needle Selection Control Knobs are set at 7.  
**Table 5** Combinations obtainable when the Needle Selection Control Knobs are set at 8.  
**Table 6** Combinations obtainable when the Needle Selection Control Knobs are set at 9.  
**Table 7** Combinations obtainable when the Needle Selection Control Knobs are set at 10.

**HOW TO READ THE TABLES:**

The black dots represent needles and the vertical lines the needle grooves, each number on which corresponds with the numbering on the Needle Selection Guide Strip being used as indicated. The black dots on the right represent the needles selected at the beginning of a row. The series of black dots on the left indicate the manner in which the needles will be automatically operated when the carriage is moved across the machine. The black dots above the horizontal line are needles in Position (B) and those below this line are in Working Position (C).

**NOTE:** When moving the carriage and at the same time the leading Needle Forwarding Lever, the black dots above the horizontal line will be the needles in Position (C) — Working Position, and those below this line will be in Position (E) at the completion of the row.

e. g. in Table 1 on the right of the diagram one needle only, at the same end as the carriage, has been pushed back into Position (B) from the line of needles in Working Position (C). The diagram therefore only shows the one needle that has been pushed back into Position (B). When the carriage is moved across the working needles, the automatic selector will operate them in the formation shown on the left of the diagram, namely 3 forward (to knit), 1 back (to tuck or hold), 3 forward, 1 back and so on to the end of the row.

---

In this same example the single needles above the line will —

- a) With the Shifting Cam Lever at "C" hold the stitch, whilst the groups of 3 needles shown below the line will knit.
- b) with the Shifting Cam Lever at "T" the single needles will not only hold the stitch of the previous row but will also come forward and pick up and hold a strand of the wool from the row being knitted by the groups of 3 needles shown below the line.

This same needle action takes place in all the combinations shown in the Tables.

**NOTE:** Tucking can only be done on **single needles** and **not on adjacent needles** simultaneously e. g. can be done in formations of  $1 \times 1$  but not  $2 \times 2$ . etc.

#### **THE NEEDLE SELECTION GUIDE STRIPS:**

Three plastic strips are supplied with the machine, and one of them is located in front of the rear track of the needle bed, and other two strips can be found clipped inside the case lid. These strips serve as a guide when selecting needles for pattern-making. It will be seen that each of two and, three faces of the strips is numbered to correspond with the numbering on the Needle Selection Control Knobs.

When working on the Needle Combinations from any of the Tables 1 to 7 the corresponding N.S.G.S. (Needle Selection Guide Strip) should first be placed in position on the Needle Bed so that the appropriately numbered face is visible to the operator.

There are 3 N.S.G.S. in all.

Two of the Strips are Flat and one is Triangular.

The faces of the Strips correspond with the Tables of Needle Combinations as follows :—

For TABLE 1. use :— 

Fig. 13A

and for TABLE 5. use the reverse side of this strip which reads as

follows :— 

Fig. 13B

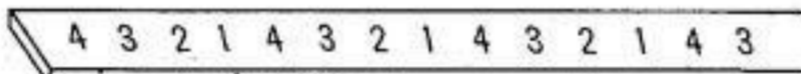
For TABLE 2. use :— 

Fig. 14A

and for TABLE 3. use the reverse side of this strip which reads as

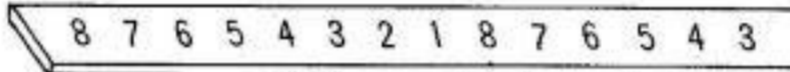
follows :— 

Fig. 14B

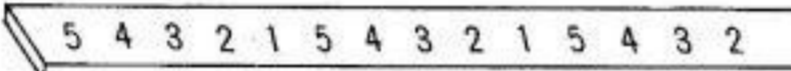
For TABLES 4, 6, & 7. use the Triangular shaped Strip with the faces visible as follows :—

for TABLE 4. 

Fig. 15A

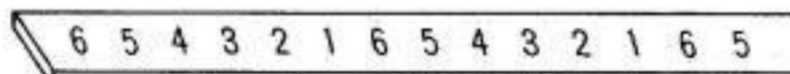
for TABLE 6. 

Fig. 15B

for TABLE 7. 

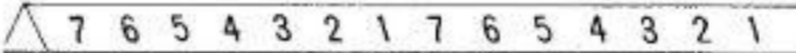
Fig. 15C



These strips are held firmly by spring clips to be found at each end and in front of rear track of the needle bed, and each strip can be easily replaced or turned as shown in Fig. 16, so that the required face is visible.

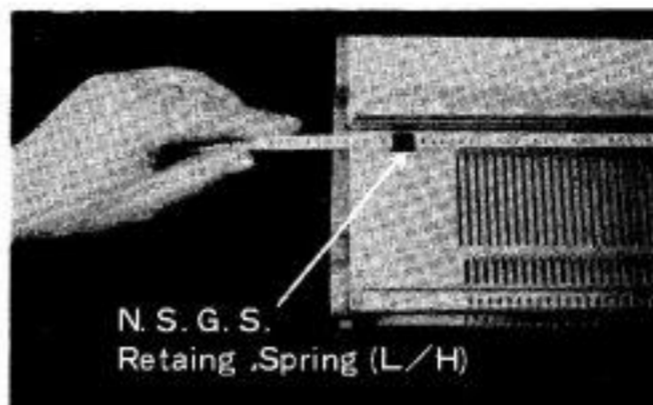

Table 1

3 2 1 4 3 2 1 4 3 2 1 4 3 2 1												4 3 2 1						
•	•	•	•	•	•	•	•	•	•	•	•	•	•	•	•	•	•	•
•	•	•	•	•	•	•	•	•	•	•	•	•	•	•	•	•	•	•
•	•	•	•	•	•	•	•	•	•	•	•	•	•	•	•	•	•	•
•	•	•	•	•	•	•	•	•	•	•	•	•	•	•	•	•	•	•

Table 2

4 3 2 1 5 4 3 2 1 5 4 3 2 1 5 4 3 2 1												5 4 3 2 1						
•	•	•	•	•	•	•	•	•	•	•	•	•	•	•	•	•	•	•
•	•	•	•	•	•	•	•	•	•	•	•	•	•	•	•	•	•	•
•	•	•	•	•	•	•	•	•	•	•	•	•	•	•	•	•	•	•
•	•	•	•	•	•	•	•	•	•	•	•	•	•	•	•	•	•	•
•	•	•	•	•	•	•	•	•	•	•	•	•	•	•	•	•	•	•
•	•	•	•	•	•	•	•	•	•	•	•	•	•	•	•	•	•	•

Table 3

6 5 4 3 2 1 6 5 4 3 2 1												6 5 4 3 2 1						
•	•	•	•	•	•	•	•	•	•	•	•	•	•	•	•	•	•	•
•	•	•	•	•	•	•	•	•	•	•	•	•	•	•	•	•	•	•
•	•	•	•	•	•	•	•	•	•	•	•	•	•	•	•	•	•	•
•	•	•	•	•	•	•	•	•	•	•	•	•	•	•	•	•	•	•
•	•	•	•	•	•	•	•	•	•	•	•	•	•	•	•	•	•	•
•	•	•	•	•	•	•	•	•	•	•	•	•	•	•	•	•	•	•
•	•	•	•	•	•	•	•	•	•	•	•	•	•	•	•	•	•	•
•	•	•	•	•	•	•	•	•	•	•	•	•	•	•	•	•	•	•
•	•	•	•	•	•	•	•	•	•	•	•	•	•	•	•	•	•	•
•	•	•	•	•	•	•	•	•	•	•	•	•	•	•	•	•	•	•
•	•	•	•	•	•	•	•	•	•	•	•	•	•	•	•	•	•	•

Fig. 16

Table 4

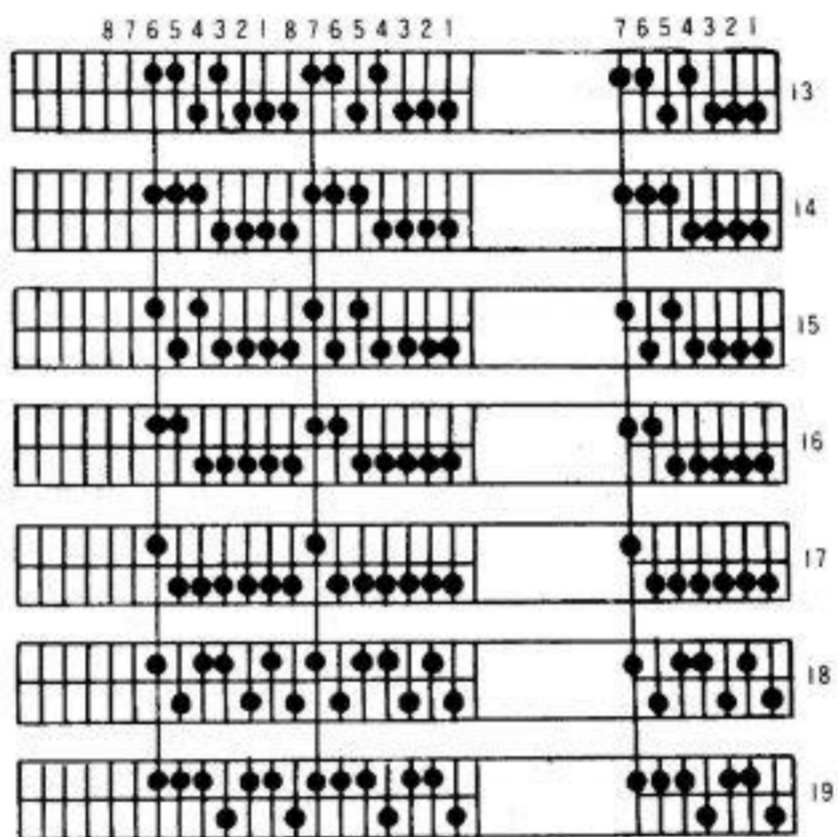
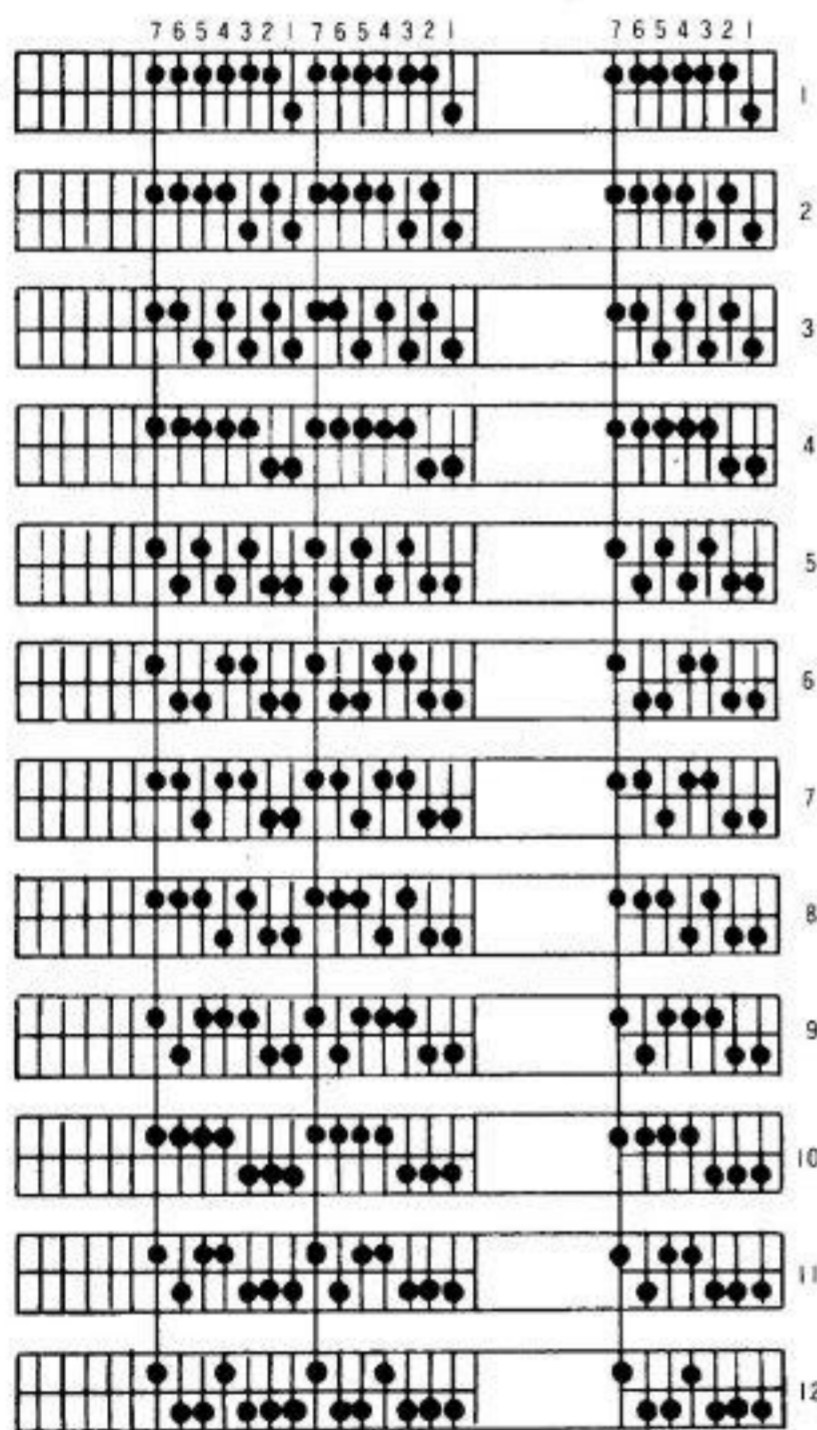

Table 5

8 7 6 5 4 3 2 1 8 7 6 5 4 3 2 1		8 7 6 5 4 3 2 1		
				17
				18
				19
				20
				21
				22
				23
				24
				25
				26
				27

Table 6

987654321987654321987654321		987654321	

Table 7

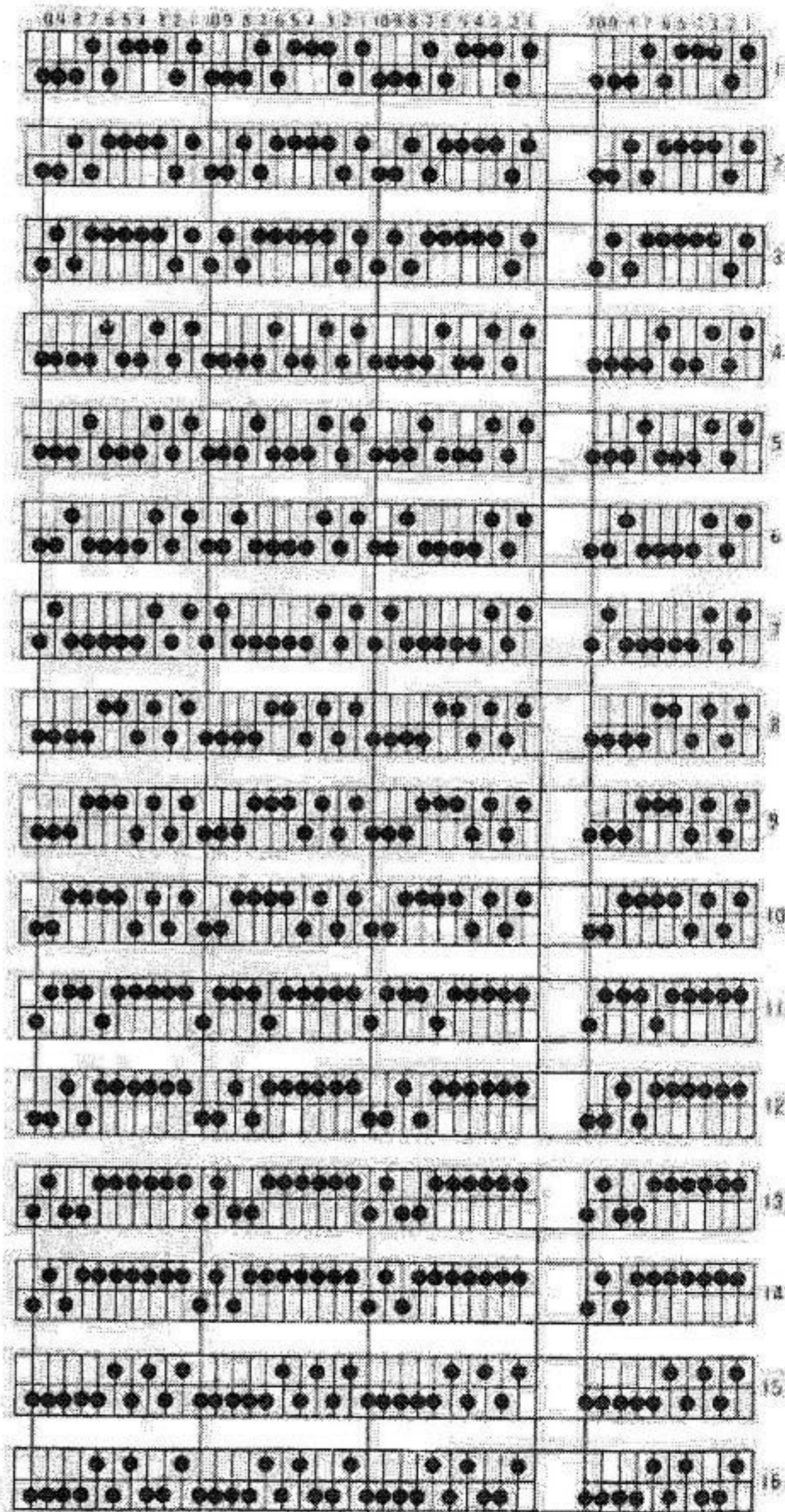
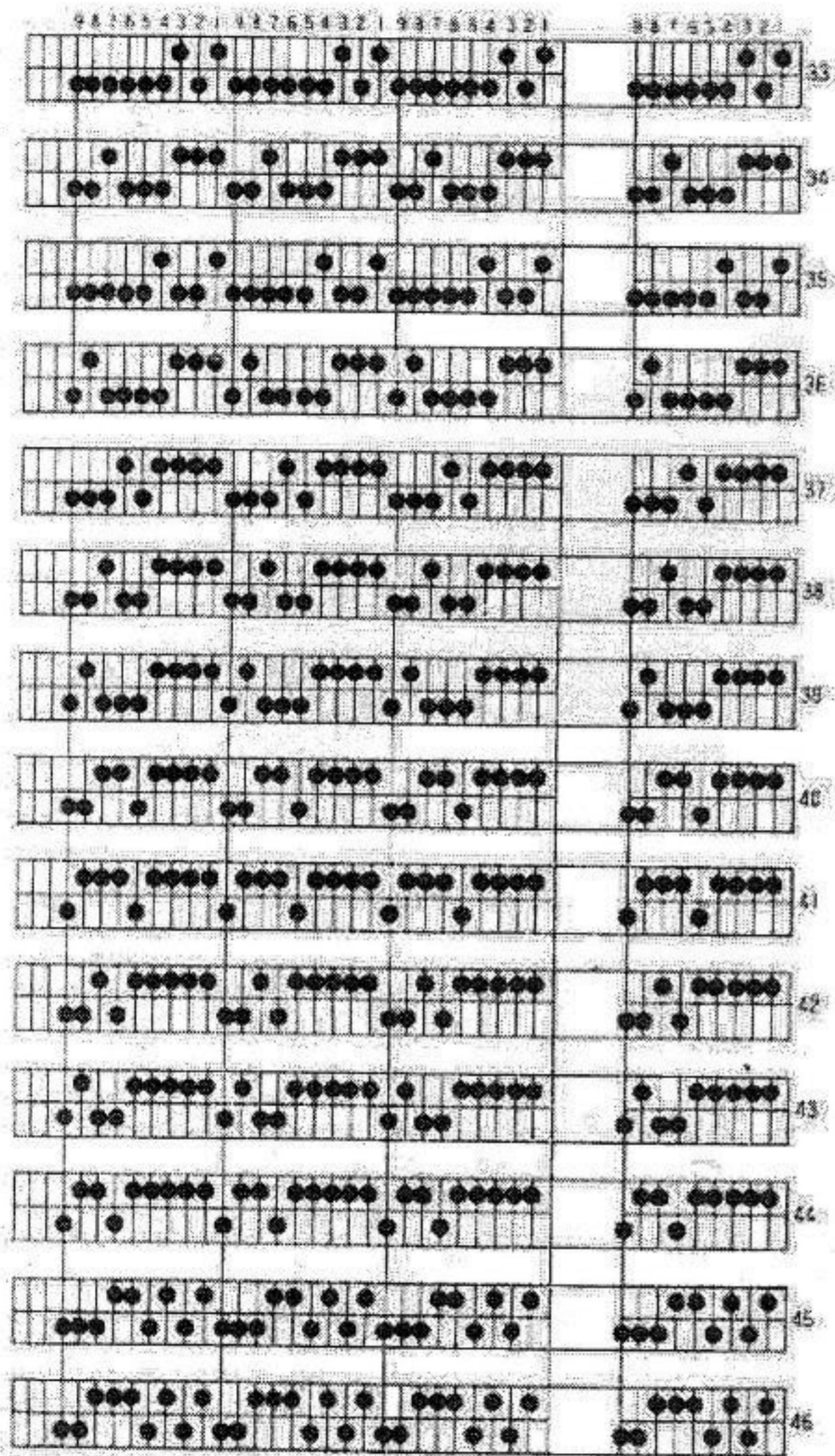

1098765432109876543210987654321	10987654321
17	17
18	18
19	19
20	20
21	21
22	22
23	23
24	24
25	25
26	26
27	27
28	28
29	29
30	30
31	31
32	32

1098765432109876543210987654321	10987654321
33	33
34	34
35	35
36	36
37	37
38	38
39	39
40	40
41	41
42	42
43	43
44	44
45	45
46	46
47	47
48	48

10987654321 | 10987654321 | 10987654321 | 10987654321

49

50

51

52

53

54

55

56

57

58

59

60

61

62

63

64

10987654321 | 10987654321 | 10987654321 | 10987654321

65

66

67

68

69

70

71

### 3. RETURN CAM LEVERS (Fig. 8—5)

These Levers control the Return Cam, and are set to two positions, namely Position 1 — Backward Position, and Position 2 — Forward Position.

**Position 1** With the lever in this setting, needles in Position (E) **will not knit** regardless of the position of the Pattern Control Knob, but needles in Position (D) **will knit** also regardless of the position of the Pattern Control Knob. Therefore, this setting is used for 'turning', 'part knitting', etc. (Fig. 17)

**Position 2** With the lever in this setting, needles in Position (E) will also knit, and therefore, with the Pattern Control Knob in Position M, needles in any of the Positions (B), (C), (D) or (E) will knit.

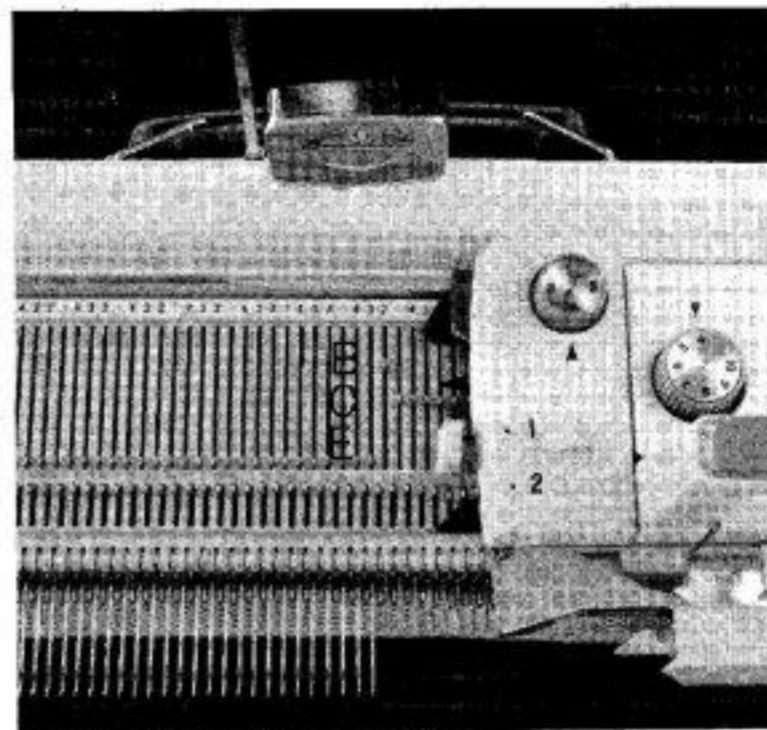

Fig. 17

### 4. NEEDLE FORWARDING LEVERS (Fig. 8—6)

Either lever will bring forward needles from Position (C) or (D) into Position (E) when moving the carriage and at the same time pushing in the leading Lever. For instance, set Pattern Control Knobs to A, Needle Selection Control Knobs to No. 4, and turn the Needle Selection Guide Strip so that the visible face is 43214321 — see Table 1, page 15. Push back into Position (B) the 2nd and 4th needles near the Carriage as shown in Fig. 18, and move the carriage at the same time pushing in the leading Needle Forwarding Lever.

You will see that every alternate needle will be forwarded into Position (E) leaving the other needles in Position (C). The needles in Position (E) are the needles previously in Position (C), and the needles in Position (C) are the needles previously pushed back into Position (B).

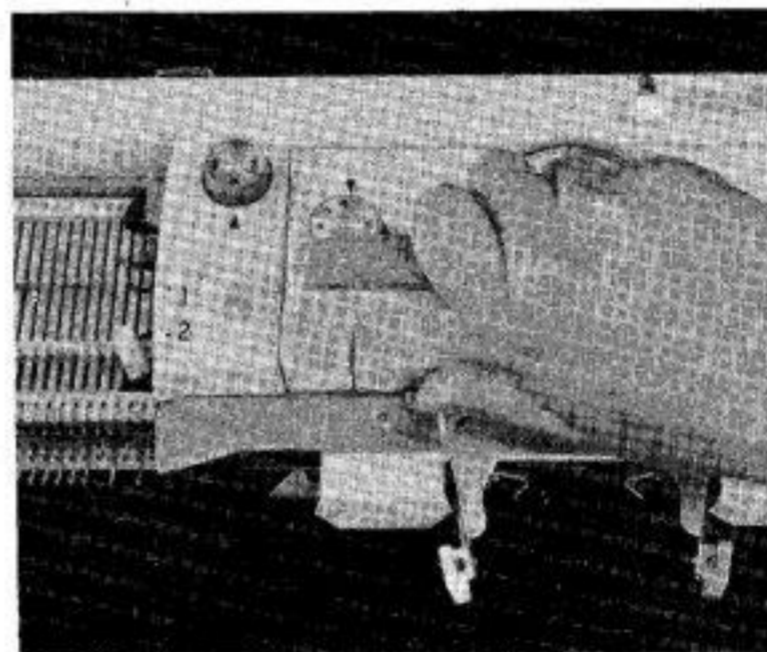

Fig. 18



---

**Note:** When using this lever, make sure that both Main Feeders are out of action in the fully open position.

### 5. TWIN MAIN FEEDERS (Fig. 8—7)

When knitting two colour patterns, thread one Feeder with the Main colour and the other with the Second colour. To change from one colour to the other — pull out of action the Feeder being used and flick into action the Feeder to be used. (see Fig. 19)

**Note:** One Feeder must always be out of action in the fully open position during knitting, otherwise damage may be caused to the machine needles.

### 6. SUBSIDIARY YARN FEEDERS (Fig. 8—8)

These Feeders are used when producing complicated colour knitting to prevent the yarns becoming entangled, and therefore, when using the Subsidiary Yarn Feeders the yarn must not be threaded into the Overhead Feeder Unit, but guided with the left hand. It should be noted that you always have to use the leading Sub-Feeder, e. g. when moving the carriage from right to left, use left hand Feeder as shown in Fig. 20.

These Feeders are used mainly for knitting two strands of yarn together — “Reversible Colour Knitting” — as shown in Fig. 20, and also for “Woven Effects” etc.

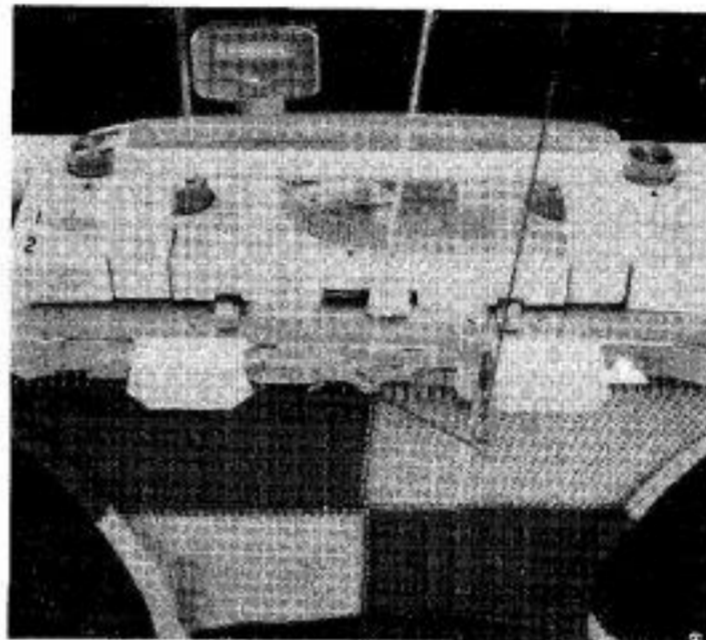

Fig. 19

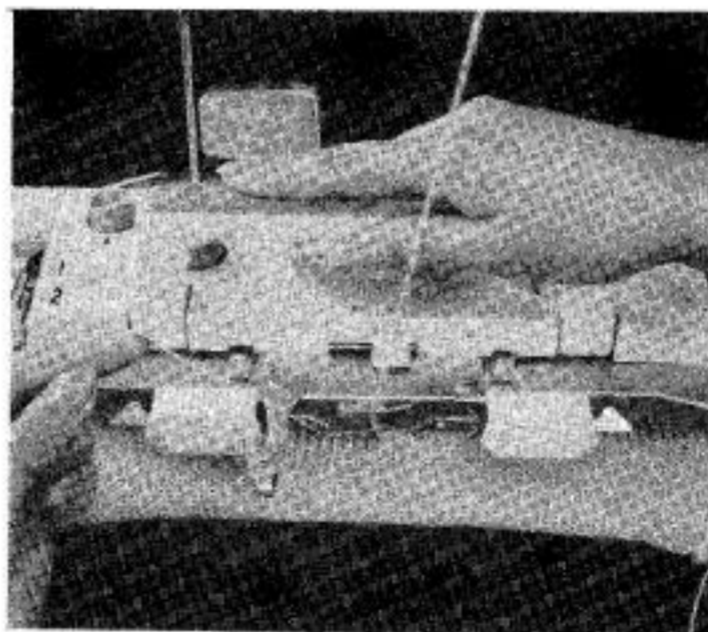

Fig. 20

---

## 7. SHIFTING CAM LEVER (T. C. LEVER) (Fig. 8—9)

This lever is located in the centre front of the carriage as shown in Fig. 8—9. Used in conjunction with the Automatic Needle Selector the two positions have the following functions:

### Lever at "T"

Selected needles, i. e. those needles pushed back from Working Position (C) into Position (B) at the start of a row (see Fig. 3) will not only hold the stitches of the previous row, but will pick up and hold wool of the row being knitted. Needles remaining in Working Position (C) will knit normally. This action is known as "tucking" and may also be used for 2-tone pattern work or for raised-stitch effects.

### Lever at "C"

Selected needles, i. e. those needles pushed back from Working Position (C) into Position (B) at the start of a row will hold the stitches of the previous row whilst the remaining needles in Working Position (C) will knit. This position is therefore used for coloured pattern work such as Fair Isle Knitting.

When plain stocking stitch is being produced, i. e. not using the Automatic Needle Selector, the Shifting Cam Lever can be in either setting "C" or "T" — preferably "C".

## 8. WEAVING FEEDERS (Fig. 8—10)

These feeders are used **exclusively** for "Weave Effect" Knitting — see page 44.

These feeders can only be used in conjunction with the Needle Forwarding Levers as shown in Fig. 21.

The Wool should always be placed in the leading feeder — i. e. the feeder nearest the knitting

When knitting with these feeders it is unnecessary to hold the wool with your hand.

**NOTE:** The 'Weaving Feeders' should never be used at the same time as the Main or Subsidiary Feeders.

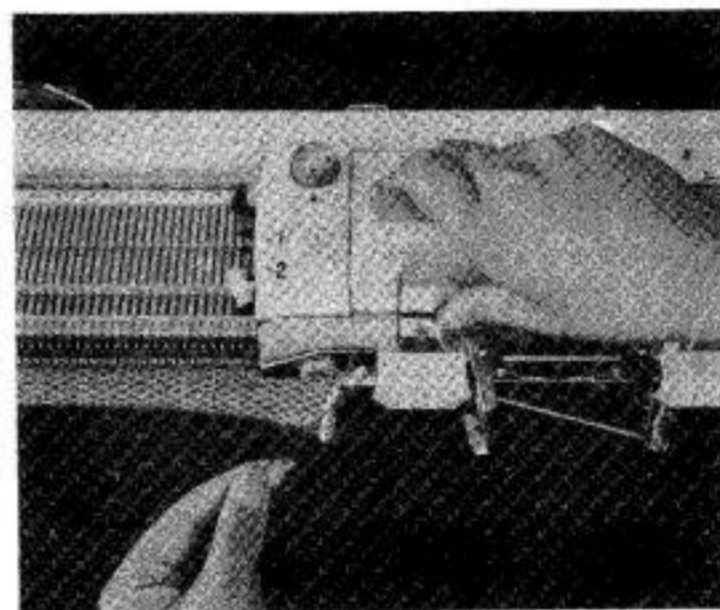

Fig. 21

---

## COLOUR PATTERN WORK—MANUAL METHOD

Where the design consists of 11 or more adjacent stitches in the one colour within the pattern (see Figs. 22 & 23) i.e. beyond the range of the Automatic Selector, the manual method as described below should be used.

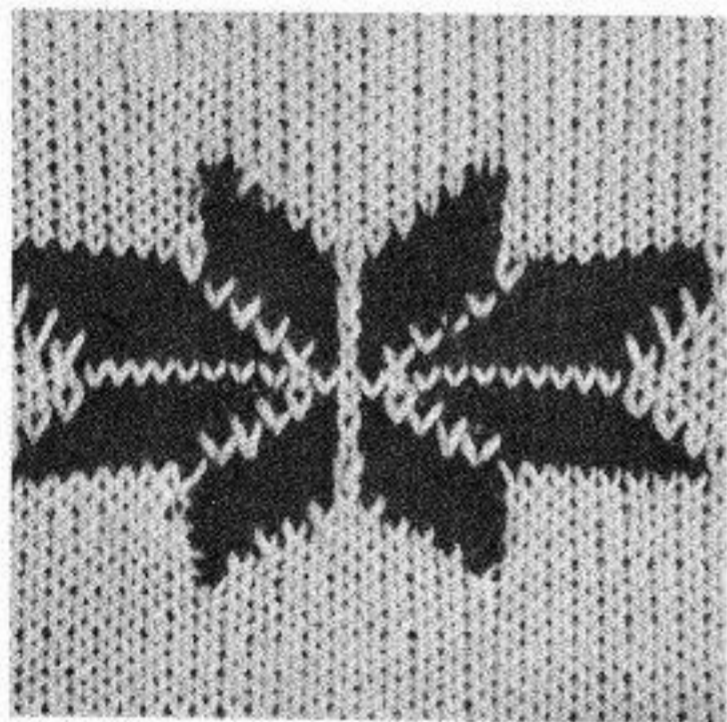

Fig. 22

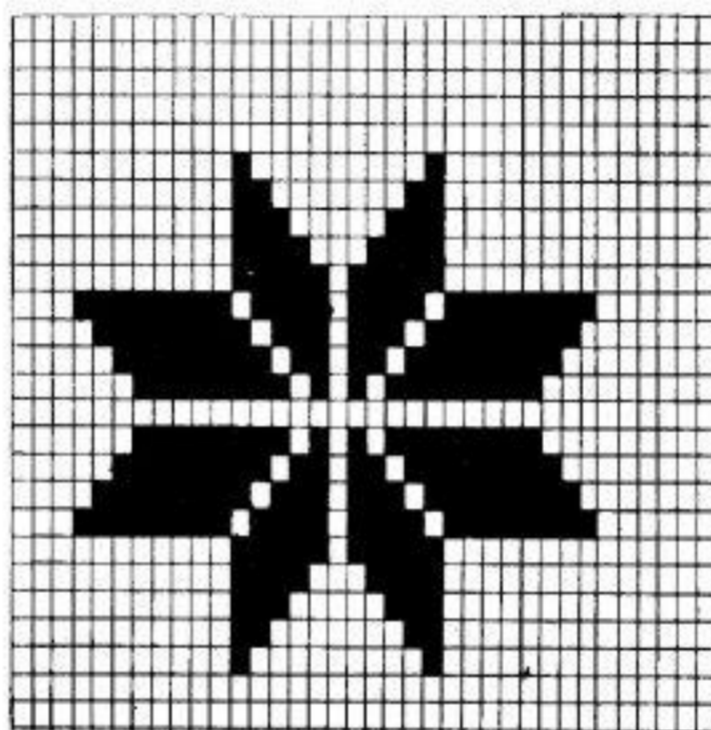

Fig. 23

- (1) Turn both Pattern Control Knobs to 'S'. Move the Shifting Cam Lever to "C" and both Return Cam Lever in Position "2".
- (2) The number of needles required for the contrasting colour should be brought forward into Position (E) (Holding Position) — Fig. 24. The contrast colour wool is then threaded in the Carriage Feeder and the row knitted.
- (3) With the carriage now at the opposite end bring into Holding Position (E) those needles which were previously in Position (C). Change to the main colour and knit 1 row.

- 
- (4) Repeat this procedure selecting the needles according to the requirements of the two-colour patterns illustrated at Figs. 22 & 23

It will be noted that only those needles in Position (E) knit a new row, whilst the needles left in Position (C) hold the stitches of the previous row. It is therefore necessary to bring these needles forward into Position (E) to receive the new colour with a further movement of the carriage. Accordingly two movements of the carriage are required in order to produce one complete row of knitting. If three colours are introduced into the one row of knitting then three movements of the carriage will be required, and so on.

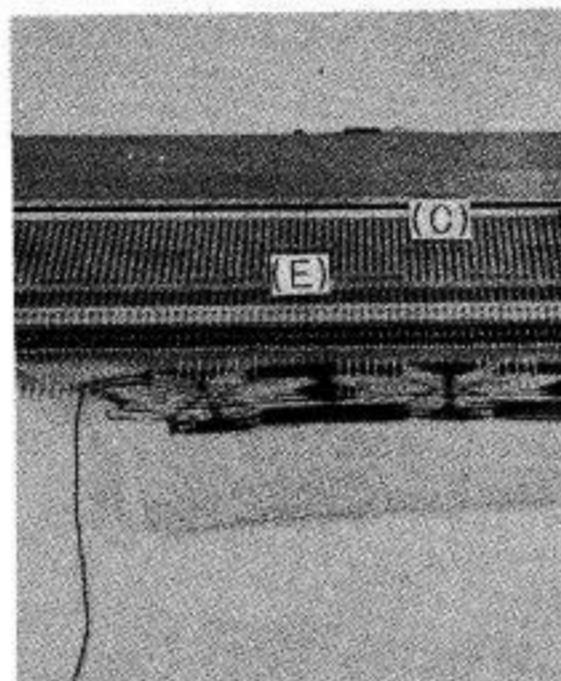

Fig. 24

**IMPORTANT** After completing each row with Pattern Knobs at 'S' make sure that all needles which are to remain in Position (C) for the next row are in a straight line in this Position.

## TUCKING PATTERN WORK — MANUAL METHOD

As in the case of Colour Pattern work if the Tucking Pattern repeats at intervals of 11 or more stitches (Figs. 25 & 26) the following manual method is employed.

- (1) Turn both Pattern Control Knobs to 'M'. Move the Shifting Cam Lever to "C" and push BACK into Position "1" both Return Cam Levers.
- (2) The number of needles required for Tucking (Holding) should be brought forward into Position (E) (Holding Position.)—  
Figs. 27 & 28.

Knit the number of rows required by the pattern with the selected needles remaining in the Holding Position. In the pattern illustrated at Fig. 25 every 12th needle is in Position (E) and 11 rows are knitted with these needles remaining in the Holding Position.

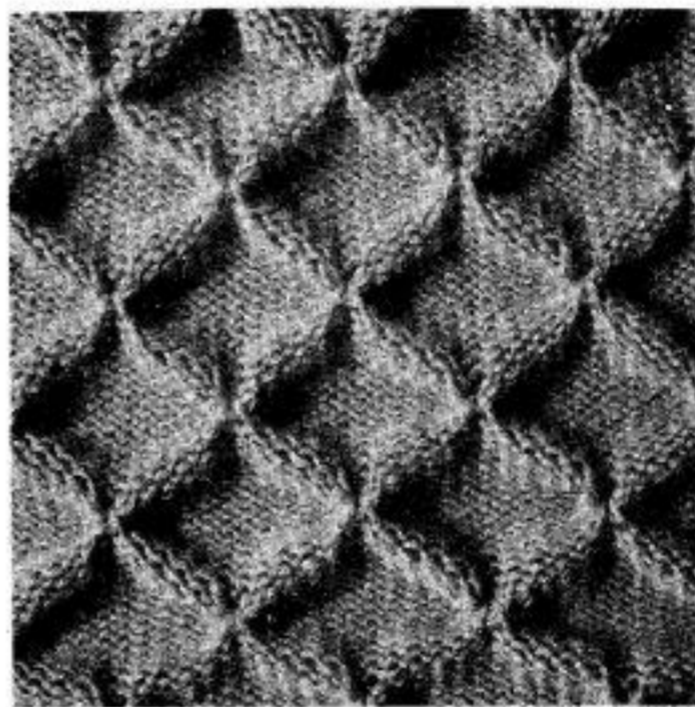

Fig. 25

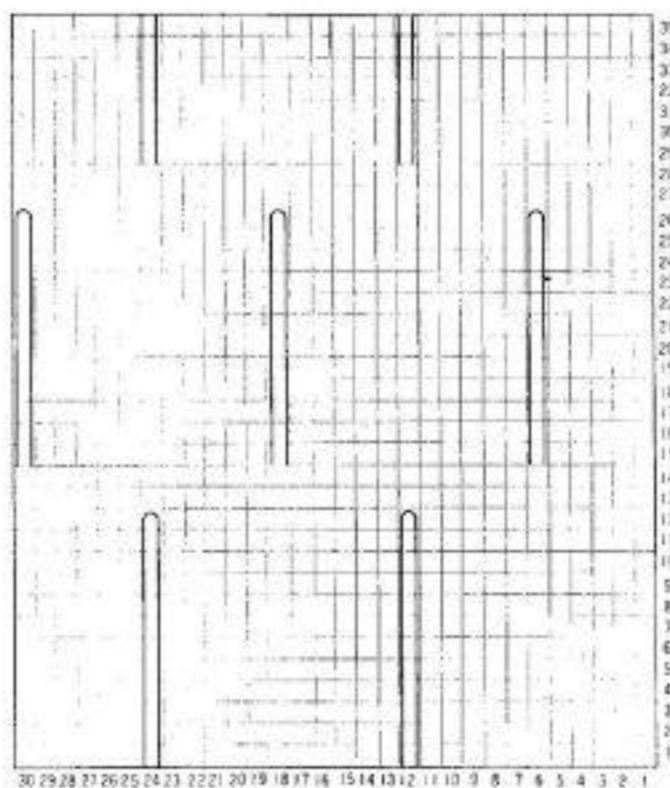

Fig. 26

---

(3) Before knitting the 12th row of the pattern illustrated at Fig. 25 the Return Cam Levers are pulled FORWARD into Position "2" so that the holding needles will knit along with the rest. At the end of the 12th row the Return Cam Levers must be pushed BACK into Position "1". After 3 rows of knitting over all the needles another sequence of single needles is brought forward into Position (E) and the procedure is repeated. (Figs. 26, 27 & 28)

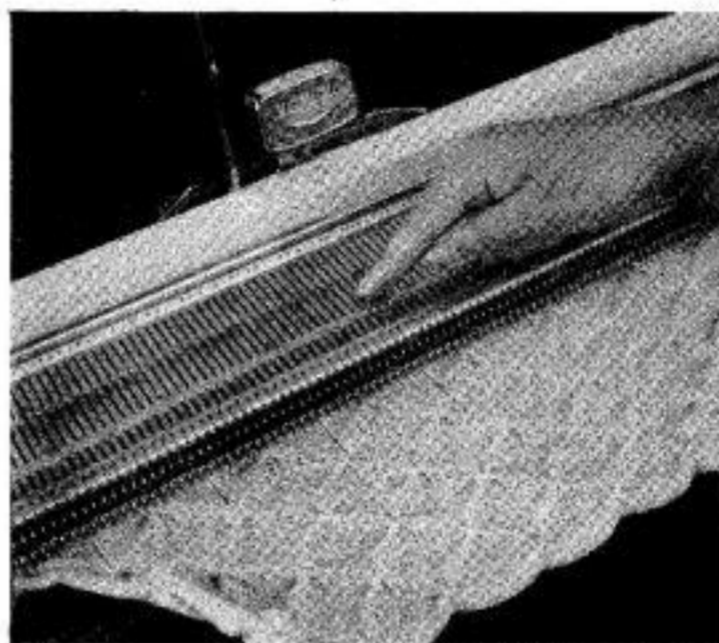

Fig. 27

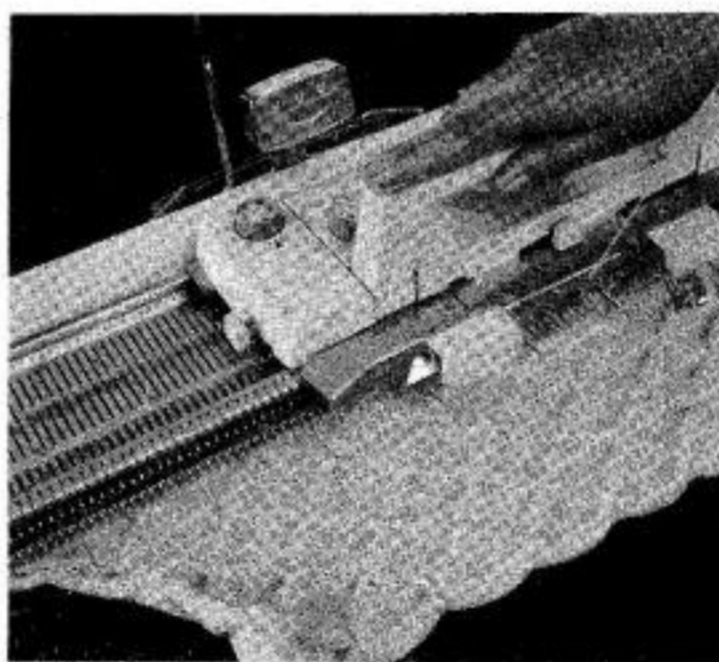

Fig. 28

## TUCKING PATTERN — AUTOMATIC METHOD

Tucking patterns can be produced automatically in the following manner:

- (1) Turn Pattern Control Knobs to 'A'. Move the Shifting Cam Lever to "T" and pull FORWARD into Position "2" the Return Cam Levers.
- (2) Turn the Needle Selection Control Knobs to number 4.5.6.7.8.9 or 10 according to the combination of needles required (see Tables of Needle Combinations).
- (3) Use the Needle Selection Guide Strip to correspond with the setting of the Needle Selection Control Knobs.
- (4) Push back into Position (B) from Position (C) those needles required for Tucking. Only the first few needles at the end require to be pushed back as the Carriage will automatically select the rest of the working needles when moved across the machine (see Tables of Needle Combination).

### HOW TO KNIT THE ONE-COLOUR TUCKING PATTERN (Fig. 29)

**Settings** Pattern Control Knobs at 'A'

Shifting Cam Lever at "T"

Return Cam Levers—Position "2"

Needle Selection Control Knobs at 4.

Needle Selection Guide Strip—4 3 2 1

**Fig. 29** One-colour Tucking Pattern

- Fig. 30** (a) The symbol "⏏" indicates a tuck stitch.  
(b) The symbol "■" indicates a needle pushed back into Position (B) from Position (C) before commencement of a row i. e. in this case, from 1st row to 4th row you should

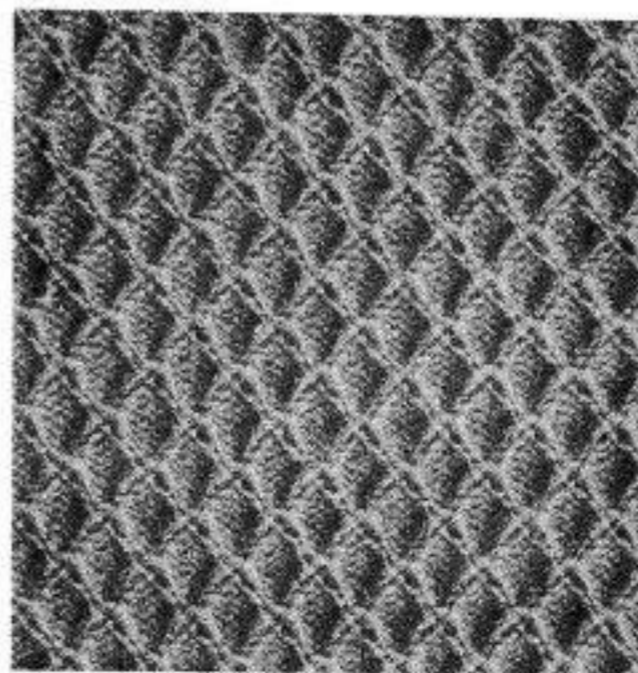

Fig. 29

push back only one needle opposite No. 4 on the Needle Guide Strip at the carriage end before knitting each row. And, in same way, from 7th to 10th row push back to Position (B) a needle opposite No. 2.

(c) Reading up the chart each square represents a stitch.

**Fig. 31** (a) Clr. denotes the Colour, and the letter 'A' represents main colour—in this case only one colour is used.

(b) N.R. means the 'Number of Rows'

(c) N.S.G.S. means "Needle Selection Guide Strip". In this case, the diagram shows that you should

knit from 1st to 4th row pushing back into position (B) only one needle opposite No. 4 on the Needle Selection Guide Strip at the commencement of each row, then after knitting 2 rows i.e. 5th and 6th rows, without selection, you should repeat the procedure from 7th to 10th row but by pushing a needle opposite No. 2 on the N.S.G.S. back into Position "B".

(d) The blank squares in the row above represent rows knitted without any needles being selected.

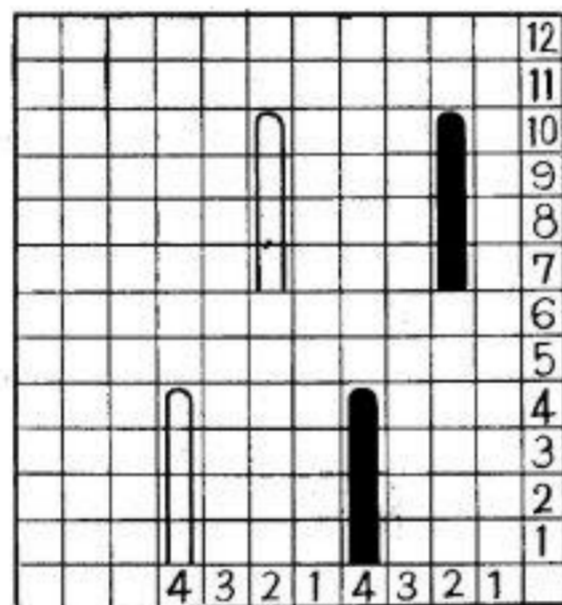

Fig. 30

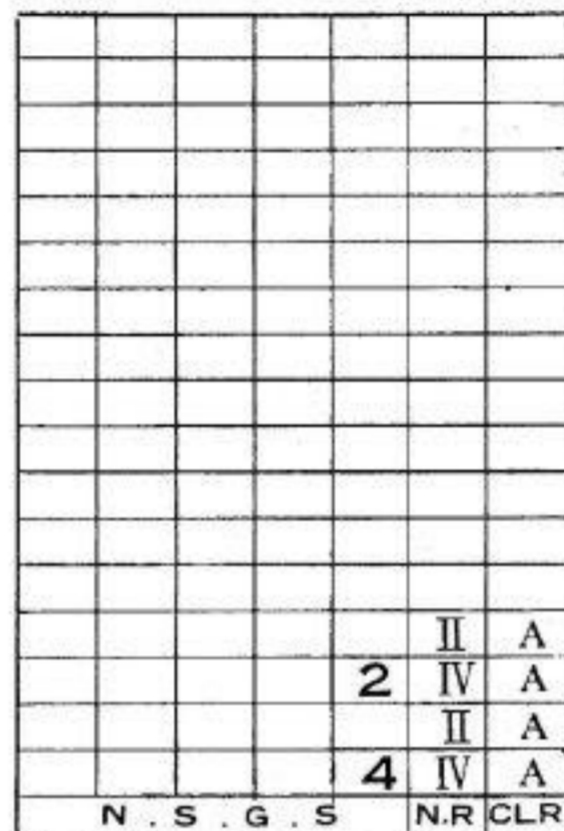

Fig. 31



---

\* **1st row** Carriage on right. Push back into Position (B) the 4th needle from the right-hand end. This needle will be that opposite No. 4 on the N.S.G.S. (Fig. 32)

Knit 1 row.

**NOTE:** You will see that every 4th needle will hold the stitch of the previous row and also pick up a strand of wool of the row being knitted whilst the remainder will knit.

**2nd row** Carriage on left. Push back into Position (B) that needle opposite the first No. 4 on the N.S.G.S. reading from left to right of the working needles. Knit 1 row.

**3rd row** Carriage on right. Push back into Position (B) the 4th needle from the right end opposite No. 4 on the N.S.G.S. Fig. 32 and knit 1 row.

**4th row** Carriage on left. Push back into Position (B) the end needle opposite No. 4. Knit 1 row.

**NOTE:** You will see that every 4th needle opposite No. 4 on the N.S.G.S. will hold the stitches of the previous 3 rows and also pick up a strand of wool of the row being knitted whilst the remainder will knit.

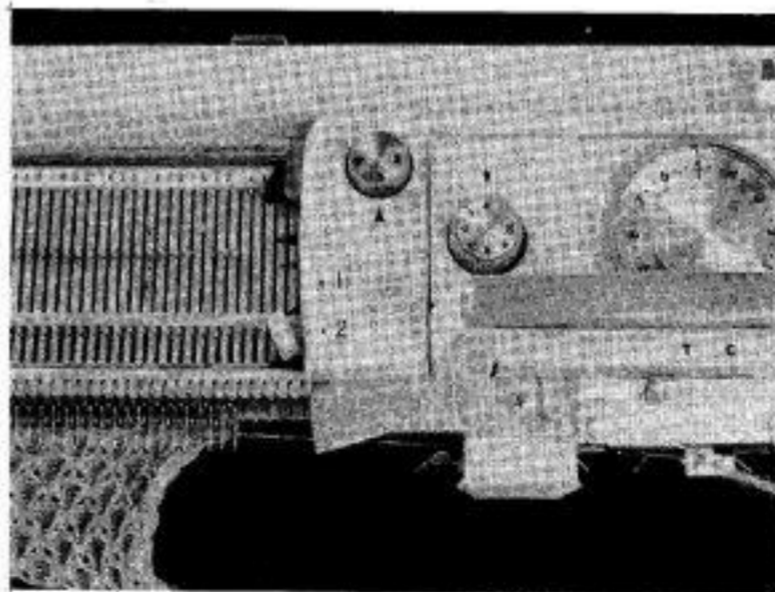

Fig. 32

- 
- 5th row** Carriage on right. Knit one row, and all the needles will knit along this row.
- 6th row** Carriage on left. Knit one row.
- 7th row** Carriage on right. Push back into Position (B) the 2nd needle from the right end opposite No. 2 on the N.S.G.S. Knit 1 row.
- 8th row** Carriage on left. Push back into Position (B) the 3rd needle from the left end needle opposite No. 2. Knit 1 row.
- 9th row** Carriage on right. Push back into Position (B) the 2nd needle from the right opposite No. 2. Knit 1 row.
- 10th row** Carriage on left. Push back into Position (B) the 3rd needle from the left and opposite No. 2. Knit 1 row.
- 11th row** Carriage on right. Knit one row, and all the needles will knit along this row.
- 12th row** Carriage on left. Knit one row, and all the needles will knit along this row. \*  
For Pattern repeat from \* to \*

## HOW TO KNIT A ONE-COLOUR PULL-UP PATTERN (Using Needle Forwarding Lever)

The one colour tucking pattern as referred to in the preceding paragraph (see Fig. 29) can also be produced using the Needle Forwarding Lever, and this method is called a 'Pull-up Pattern'. Formation of the stitches is the same as for a 'Tucking Pattern', but the tucking pattern has a slightly more raised effect. To produce the pull-up pattern as referred to in Figs. 29, 30 and 31, proceed as follows:

**Settings** Pattern Control Knobs at "A"  
Shifting Cam Lever at "C"  
Return Cam Levers to Position 1  
Needle Selection Control Knobs at 4  
Needle Selection Guide Strip - - 43214321

**Pattern Chart** Refer to Fig. 30

\* **1st row** Carriage on right. Open **both** Feeders (out of action position) as shown in Fig. 33. Push in the Row Counter Trip Arm so that the Row Counter will not register.

Push back into Position (B) the end needles opposite Nos. 1, 2 and 3 on the N.S.G.S. Move carriage from right to left at the same time pushing in the leading Needle Forwarding Lever (left hand lever). (Fig. 33)

You will see that every 4th needle will come forward into Position (E). With carriage on left, turn the leading (right hand) Pattern Control Knob to 'S' and return the carriage from left to right.

These two movements of the carriage are made only to bring forward every 4th needle into Position (E).

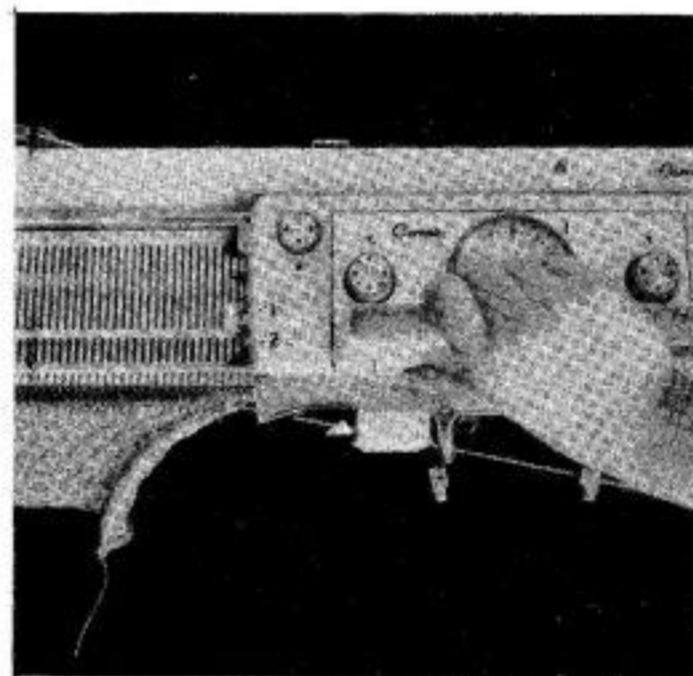

Fig. 33

---

Flick the threaded carriage feeder in position, pull out the Row Counter Trip Arm, and turn the right hand Pattern Control Knob to 'A'.

Knit the first row by moving the carriage from right to left.

- 2nd row** Carriage on left. Knit 2nd row by moving the carriage from left to right.
- 3rd row** Carriage on right. Knit 3rd row by moving the carriage from right to left.
- 4th row** Carriage on left. Knit 4th row by moving the carriage from left to right.
- 5th row** Carriage on right. Bring forward to Position 2 the leading Return Cam Lever (left hand), and knit this row. You will see that all the needles have now been aligned in Position (C).
- 6th row** Carriage on left. Move carriage from left to right.
- 7th row** Carriage on right. Push back into Position 1 the leading Return Cam Lever. Pull the Yarn Feeder out of action. Push into Position (B) the end needles opposite Nos. 1, 3 and 4. Push in the Row Counter Trip Arm, and move carriage at the same time pushing in the leading Needle Forwarding Lever (left hand). You will see that every 4th needle opposite No. 2 is now brought forward into Position (E). With carriage on left, turn leading Pattern Control Knob to 'S' and move carriage from left to right. Flick the Yarn Feeder into action. Pull out the Row Counter Trip Arm and turn the right hand Pattern Control Knob to "A". Knit this row.

**8th — 10th row**

Simply move the Carriage across all the needles.

- 11th row** Carriage on right. Bring forward the leading Return Cam Lever into Position 2, and knit this row.
- 12th row** Push back the left hand Return Cam Lever into Position 1 and knit this row moving the carriage from left to right. \*

For pattern repeat from \* to \*



---

Reading along the pattern chart from right to left each square represents a needle.  
Reading up the Chart each square represents a row.  
In the margin 'A' is the main colour — 'B' the contrast colour.  
The figures 6.5.4.3.2.1. indicate the six end needles at the right hand end. The  
Needle Guide Strip to correspond with these numbers should be used.

**Fig. 36** This diagram shows —  
The order in which the colours are introduced reading upwards from the bottom  
right-hand corner. 'A' is the main colour — 'B' the contrast colour.

C|rs. — Colours  
N. R. — Number of Rows  
N. S. G. S. — Needle Selection Guide Strip

### **HOW TO KNIT THE TWO-COLOUR FIGURED PATTERN (Fig. 34)**

**Settings:** Pattern Control Knobs at 'A'  
Shifting Cam Lever at "C"  
Return Cam Levers in Position "2"  
Needle Selection Control Knobs at 6  
Needle Selection Guide Strip — 6. 5. 4. 3. 2. 1.

- \* 1st row With Carriage on right. Push back into Position (B) the 3rd and 6th needles from the right end opposite Nos. 3 and 6. (Fig. 36) Knit 1 row with main colour. (Fig. 37)
- 2nd row With carriage on left. Push back into Position (B) 1st and 4th needles opposite Nos. 6 and 3. Knit 1 row.
- 3rd row With carriage on right. Replace main colour with contrast colour by switching feeders. Push back into Position (B) 2nd and 5th needles from the right end opposite Nos. 2 and 5, and knit with contrast colour.
- 4th row With carriage on left, push back into Position (B) 2nd and 5th needles from the left opposite Nos. 2 and 5. Knit 1 row with contrast colour.
- 5th row With carriage on right, push back into Position (B) the 1st and 4th needles opposite Nos. 1 and 4. Knit 1 row with contrast colour.
- 6th row With carriage on left, push back into Position (B) the 3rd and 6th needles from the left end opposite Nos. 3 and 6. Knit 1 row with contrast colour. \*
- For Pattern repeat from \* to \*

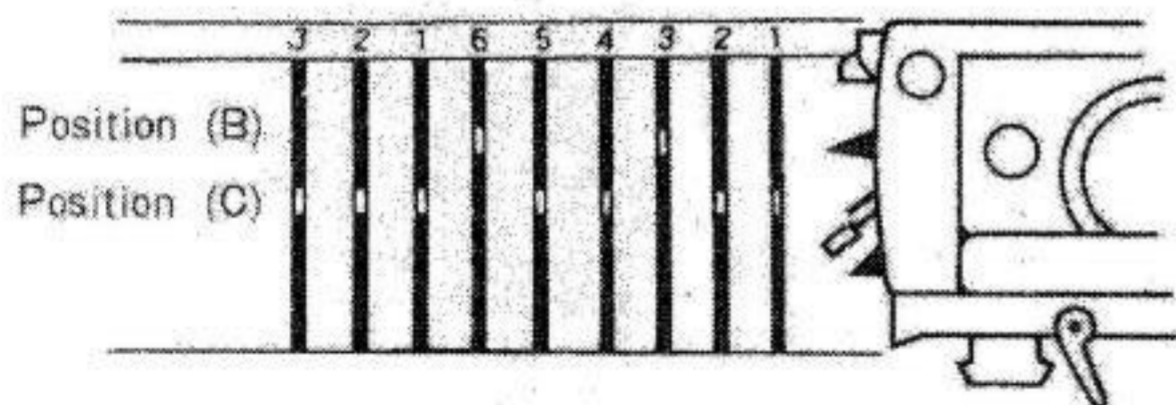

Fig. 36

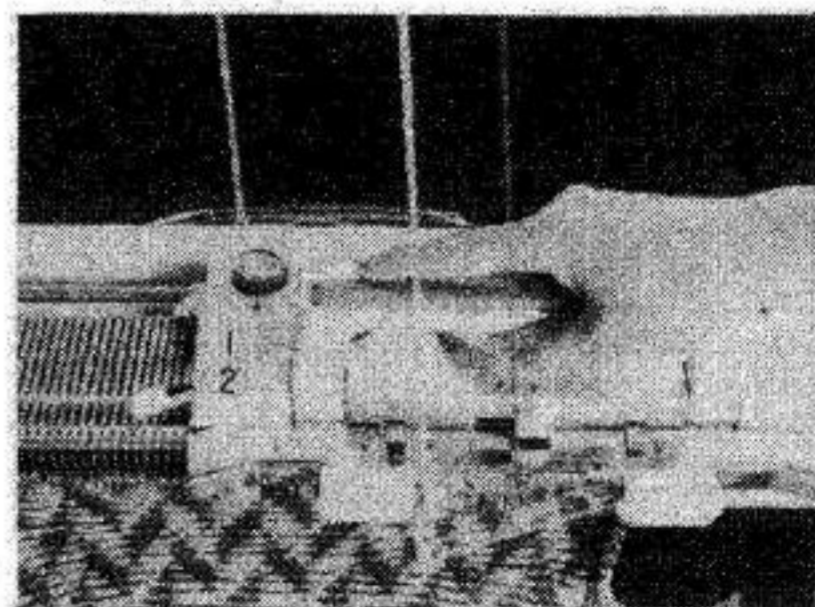
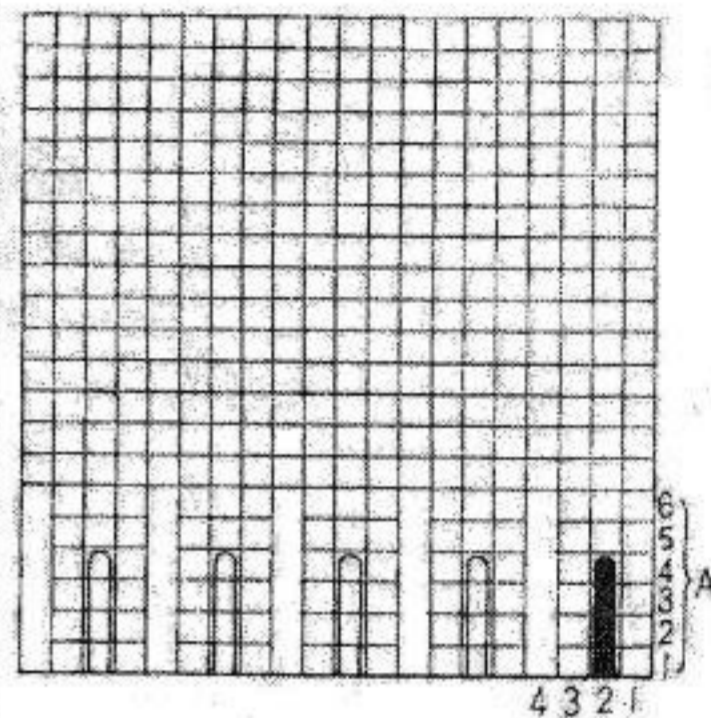
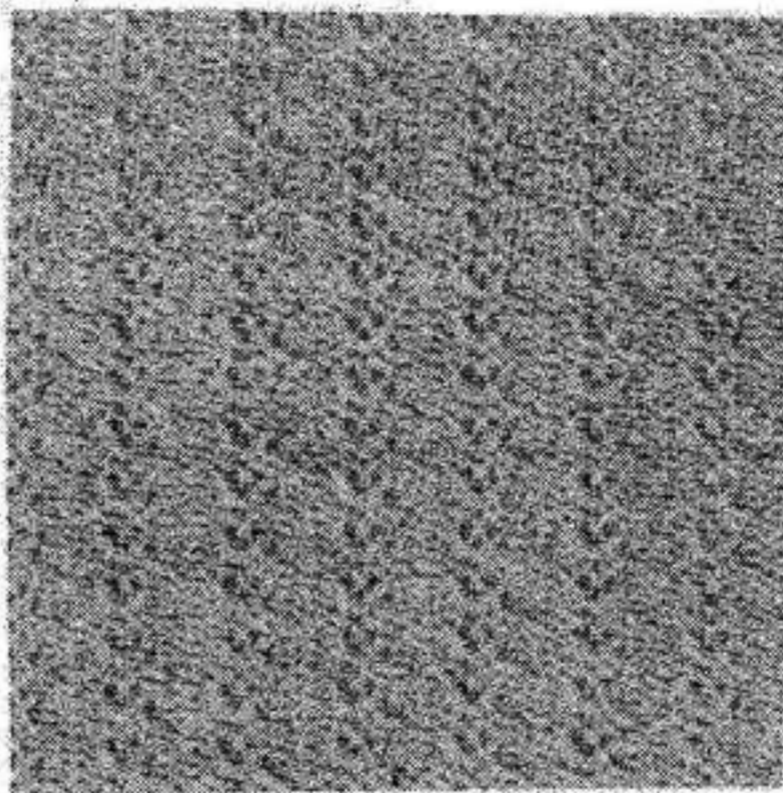

Fig. 37

# FANCY LACE PATTERN — AUTOMATIC METHOD (Fig. 38)

**SETTINGS:** Pattern Control Knobs at "A"  
 Shifting Cam Lever at "T"  
 Return Cam Levers at "2"  
 Needle Selection Control Knobs at 4  
 Needle Selection Guide Strip—4. 3. 2. 1.



**FIG. 38** Fancy Lace Pattern with One Colour

Fig. 38

Fig. 39

**FIG. 39** The symbol "□" indicates a tucking stitch.

The solid black "■" represents the needle selected for tucking stitch at the beginning of a row.

Reading along the pattern chart from right to left each square represents a needle, but in this case, it should be noted that every 4th needle from the right end needle i. e., opposite No. 4 on the N.S.G.S., must be pushed back into rest position—Position (A).

Before commencing to knit the pattern you should transfer every 4th stitch (opposite No. 4 on the N.S.G.S.) onto each adjacent needle with the Transfer Tool, and the empty needles should be pushed back into Position (A) as shown in Fig. 41

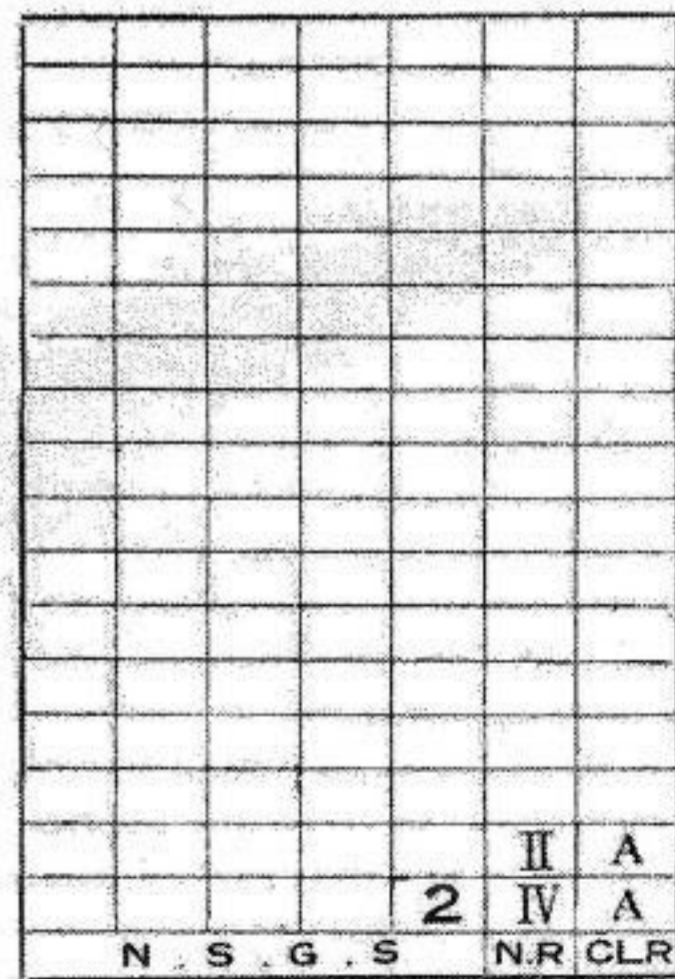

Fig. 40



- 
- \* **1st row** With carriage on right. Push back into Position (B) the 2nd needle from right hand end opposite No. 2 on the N.S.G.S. Knit 1 row. (Fig. 41)
- 2nd row** With carriage on left. Push back into Position (B) at the left hand end the 2nd needle at that end — the needle opposite No. 2 on the N.S.G.S. and knit 1 row.
- 3rd row** With carriage on right. Push back into Position (B) 2nd needle from right and knit 1 row.
- 4th row** With carriage on left, push back into Position (B) a needle opposite No. 2 nearest to the carriage. Knit 1 row.
- 5th row** With carriage on right. Knit a row across all working needles. (Fig. 41)
- 6th row** With carriage on left. Knit a row across all working needles. \*
- For Pattern repeat from \* to \*.

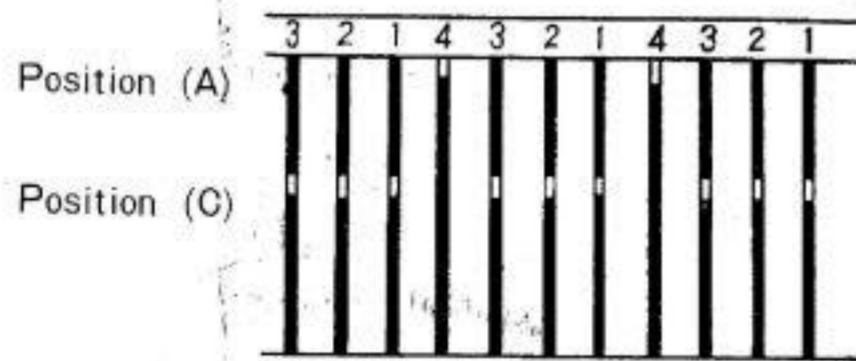

Fig. 42

---

## FANCY RIBBING STITCHES. (Fig. 43)

**SETTING** ·· Pattern Control Knob L/H at "A"  
R/H at "S"

Shifting Cam Lever at "T"

Return Cam Levers at "1"

Needle Selection Control Knobs at 4.

Needle Selection Guide Strip — 4. 3. 2. 1.

**1st row** \* With carriage on right, push back the two needles at the carriage end opposite numbers 2 and 4 on the N.S.G.S. into position "B".

Pull the feeder out of action and, holding in the leading Needle Forwarding Lever (the left hand lever) move the carriage from right to left. (Fig. 44)

Making sure that the leading (right hand) Return Cam Lever is in position 1, (Fig. 45) bring the carriage back to the right.

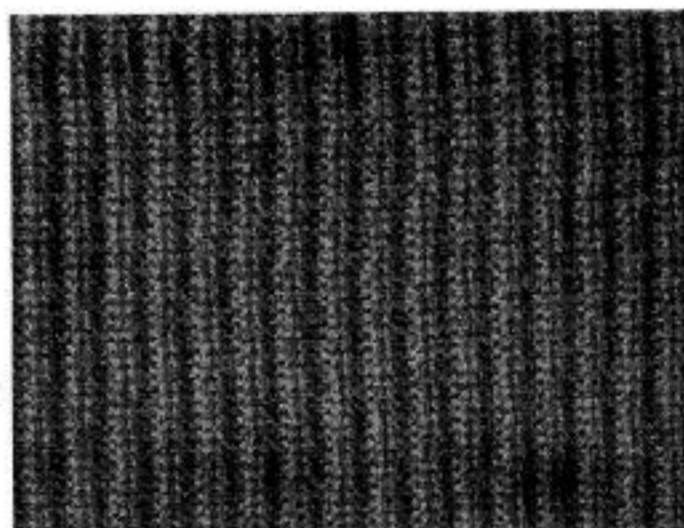

Fig. 43

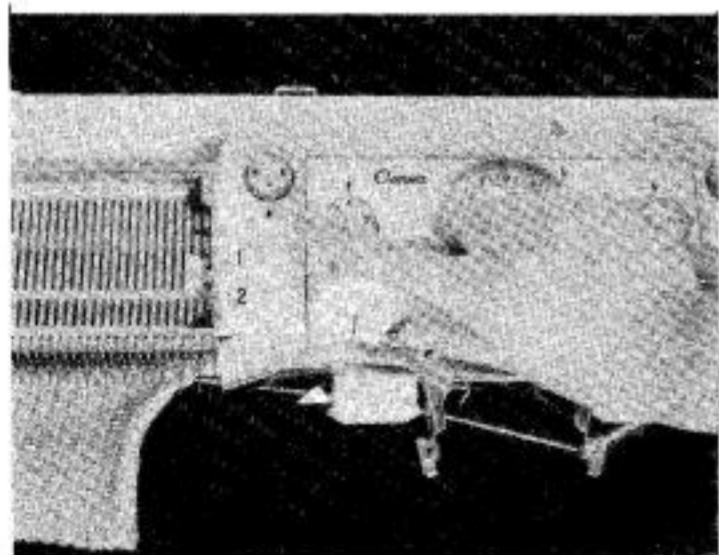

Fig. 44

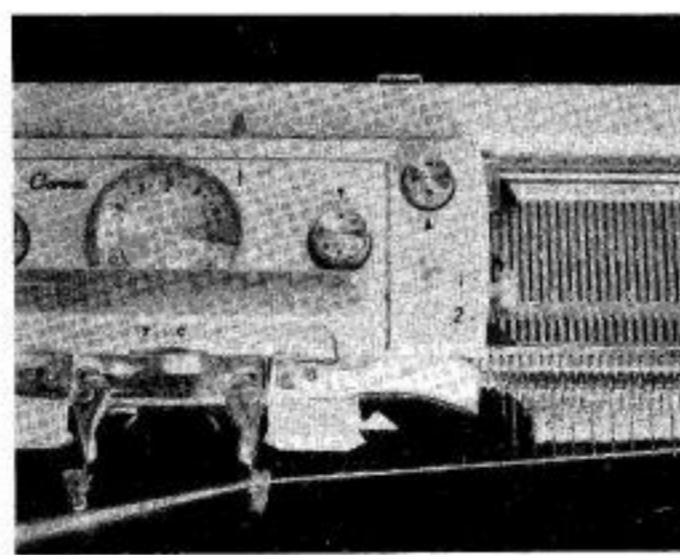

Fig. 45

The above operations are to bring forward into position "E" every alternate needle.

Now, with carriage on right, flick into action the feeder and move the carriage across the needles to the left (Fig. 46)

**2nd row** With carriage on left, bring forward the leading (right hand) Return Cam Lever to position 2 and knit this row. (Fig. 47) Push back the right hand Return Cam Lever into position 1.

Repeat from \* to \*

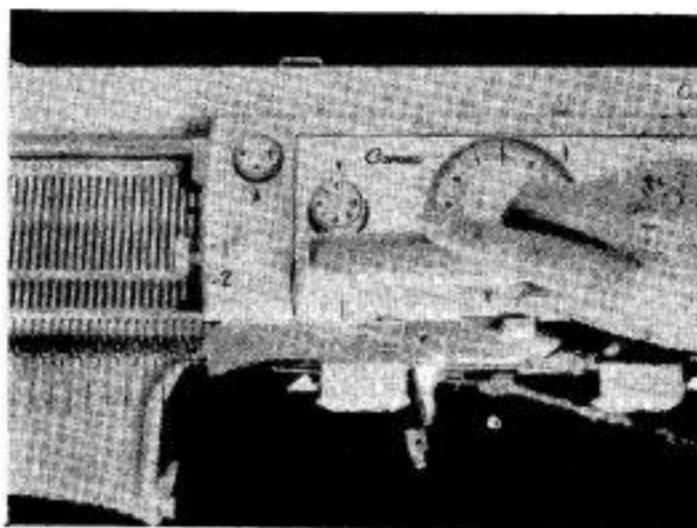

Fig. 46

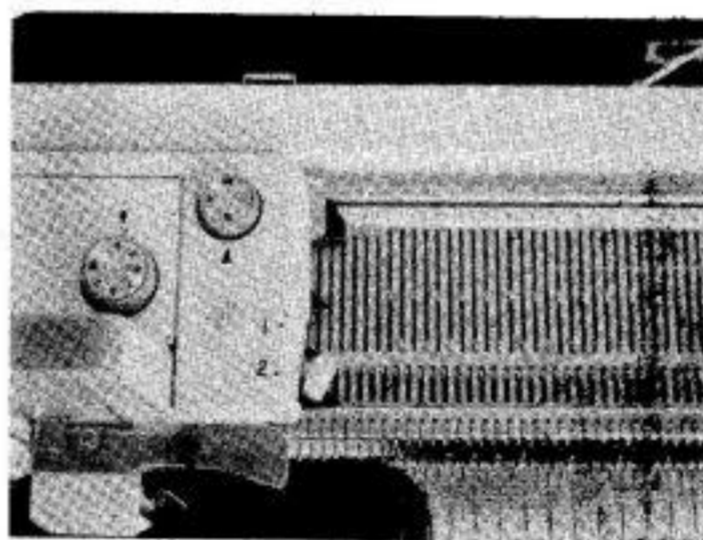

Fig. 47

---

## WEAVE EFFECT KNITTING (Fig. 48)

### METHOD 1 — Using Subsidiary Yarn Feeders

**SETTINGS:** Pattern Control Knobs at "A"  
Shifting Cam Lever at "C"  
Return Cam Levers — Position 2  
Needle Selection Control Knobs at 4  
Needle Selection Guide Strip — 4 3 2 1  
4 3 2 1

**1st row** With carriage on right. Knit one row with main colour threaded in one of the Main Feeders.

**2nd row** Carriage on left. Turn right hand Pattern Control Knob to "S" and move the carriage from left to right. The actual knitting of the 2nd row will start from right end.

Turn right hand Pattern Control Knob to "A". Push back 2 needles at the carriage end opposite Nos. 2 and 4 on the N. S. G. S. into Position (B). Form a loop in the end of the contrasting colour wool and hang it onto the hook of the needle in Position (B) nearest the end. \*Pull Main Feeder out of action, and hold the contrasting colour with your left hand and guide it into the leading Subsidiary Yarn Feeder (left hand). Push in the leading Needle Forwarding Lever move the carriage across the needles. (Fig. 49) This completes the 2nd row.

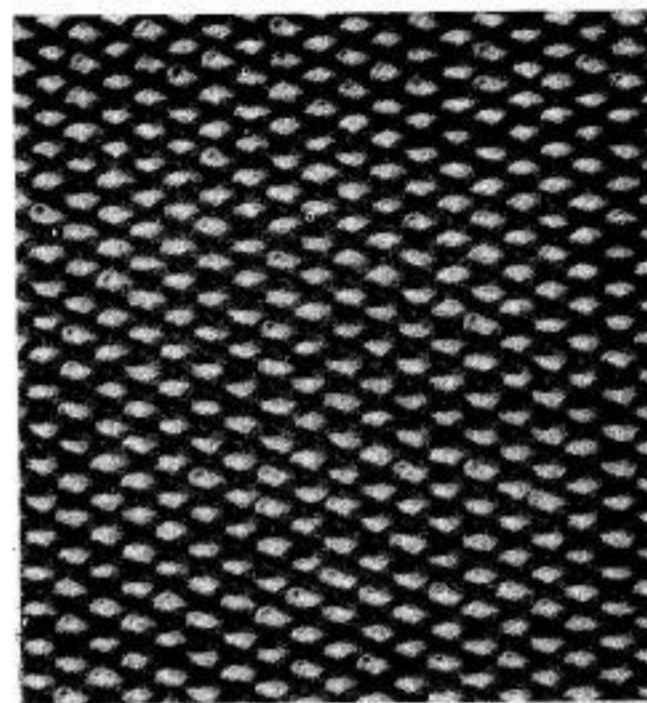

Fig. 48

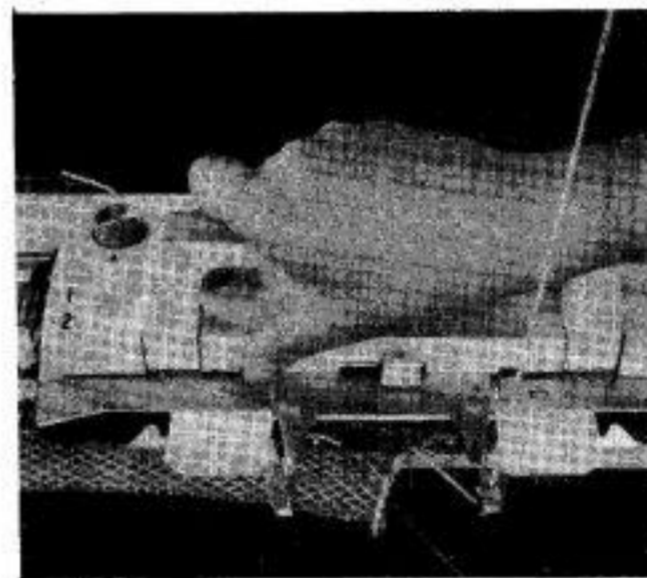

Fig. 49

- 
- 3rd row** Carriage on left. Remove the contrasting colour from Subsidiary Yarn Feeder, and flick the Main Feeder with main colour wool into action. Knit this row moving the carriage across from left to right.
- 4th row** Carriage on right. Turn leading Pattern Control Knob (left hand) to "S" and move the carriage from right to left. Turn the left hand Pattern Control Knob back to "A". Push back 2 needles at the Carriage end opposite Nos. 1 and 3 into Position (B). Pull out of action the Main Feeder and wind the contrasting colour wool in a **clockwise direction** once around the hook of extreme end needle pushed back into Position (B). Holding this contrasting colour with your left hand, guide it into the leading Subsidiary Yarn Feeder (right hand). Knit this row by moving the carriage from left to right at the same time pushing in the leading Needle Forwarding Lever (right hand).
- 5th row** Carriage on right. Remove the contrasting colour from Subsidiary Yarn Feeder. Flick the Main Feeder into action and knit this row.
- 6th row** Carriage on left. Turn right hand Pattern Control Knob to "S" and move the carriage from left to right. Turn right hand Pattern Control Knob to "A". Push back 2 needles at the carriage end opposite Nos. 2 and 4 on the N.S.G.S. into Position (B), and wind the contrasting colour wool in an **anti-clockwise direction** once around the hook of the extreme end needle pushed back into Position (B). \* /  
Repeat from \* to \*

**Note:** An alternative method for moving the carriage from one end of the machine to the other, is, by raising the Carriage slightly at the front to clear the needles and slide it along the back Runner Rail to left or right, see Fig. 50. This method is also useful should any obstruction occur during knitting causing the Carriage to jam in the middle of a row. Before the front of the Carriage is lowered it must be moved to the **extreme end of the machine** otherwise the Sinker Cam will be unable to engage the Butts of the Sinker Needles.

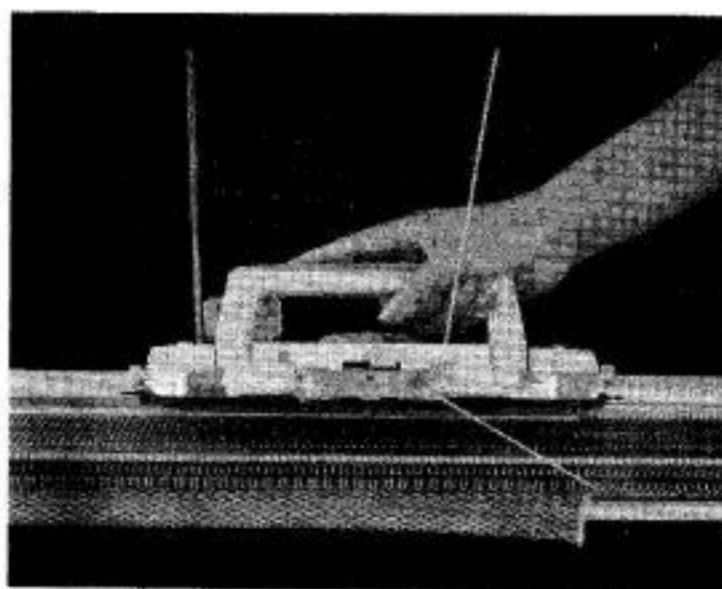

Fig. 50

---

## METHOD 2—Using Weaving Feeders.

“Weave Effect” Knitting — see Fig.48 — can also be produced using the Weaving Feeders.

**SETTINGS :** Same as Method 1.

**1st row** With Carriage on right, using main feeder, knit 1 row in main colour.

**2nd row** Carriage on left, turn right hand Pattern Control Knob to “S” and move carriage back to right. Turn right Pattern Control Knob to “A”. Push back two needles at the carriage end opposite Nos. 2 and 4 on the N.S.G.S. into Position “B”. Form a loop in the end of the contrasting colour wool and hang this loop in the hook of the end needle pushed back into position “B” nearest the carriage.

\* Pull out of action the main feeder and place the contrasting colour wool in the leading (left hand) Weaving Feeder as shown in Fig. 51.

Holding in the leading Needle Forwarding Lever, move the carriage across to the left and, at the same time, hold the wool taut until the right hand end needle is just under the leading Weaving Feeder (Fig. 51). Allowing the wool to run freely through your fingers, continue to knit this row.

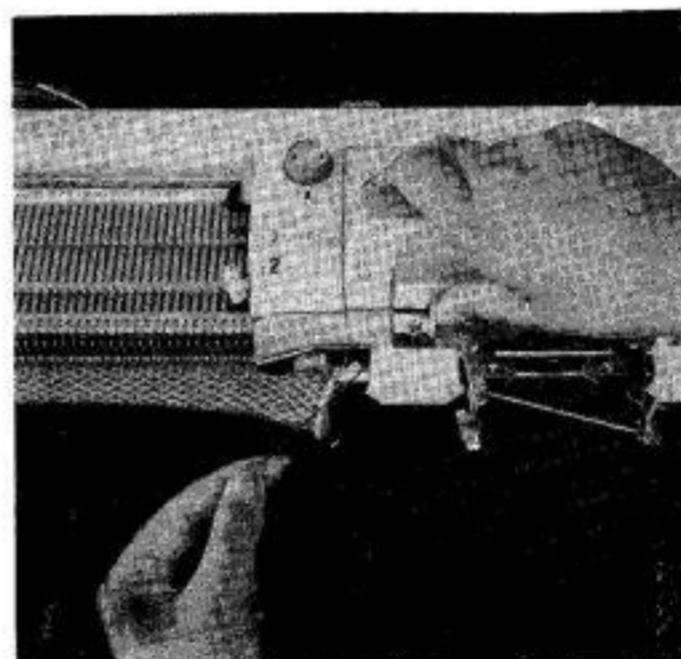

Fig. 51

**3rd row** Carriage on left. Remove the contrasting colour wool from the Weaving Feeder and flick the main feeder, containing the main colour wool, into action and knit this row.

---

**4th row** Carriage on right. Turn left hand Pattern Control Knob to "S" and move carriage back to left. Turn left hand Pattern Control Knob to "A". Push back two needles at the carriage end opposite Nos. 1 and 3 on the N.S.G.S. into Position "B". Pull out of action the Main Feeder and wind the contrasting colour wool in a **clockwise direction** once round the hook of the extreme end needle in Position "B". Place the contrasting colour wool into the leading (right hand) Weaving Feeder. Holding in the leading Needle Forwarding Lever, move the carriage across to the right and, at the same time, pulling back the loose wool until the left hand end needle is just under the leading Weaving Feeder.

**5th row** Carriage on right. Remove the contrasting colour from the Weaving Feeder and flick into action, the Main Feeder containing main colour. Knit this row.

**6th row** Carriage on left. Turn right hand Pattern Control Knob to "S" and move carriage back to right. Turn right hand Pattern Control Knob back to "A". Push back two needles at the carriage end, opposite Nos. 2 and 4 on the N.S.G.S. into position "B" and wind the contrasting colour wool in an **anti-clockwise** direction, once round the hook of the extreme end needle in position "B" \*

Repeat from \* to \*

The method described for Weave Effect Knitting using a needle selection of  $1 \times 1$  can be varied by using a selection of  $2 \times 2$  for every alternate row or  $2 \times 1$  for every third row etc.

---

## REVERSIBLE COLOUR KNITTING

Two strands of wool are knitted together. The main colour should be threaded into the Main Feeder and contrasting colour should be fed through the leading Subsidiary Feeder. The contrasting colour will appear on the knit-side and the main colour on the purl-side of the fabric.

It should be emphasised that a fine yarn must be used as the contrasting colour.

**Settings** Pattern Control Knobs at "M"

Shifting Cam Lever at "C"

Return Cam Lever — Position 2

**Note:** When producing "Reversible Colour Knitting" the desired effect can only be obtained in plain Stocking Stitch.

**1st row** Thread the main colour wool into one of the Main Feeders. With the left hand guide the fine contrasting colour yarn through the leading Subsidiary Feeder (left hand), and move carriage from right to left. (Fig. 52)

**2nd row** Still holding the contrasting colour with your left hand, transfer it to the leading right hand Sub-Feeder and move the carriage across to the right.

Repeat the above procedure.

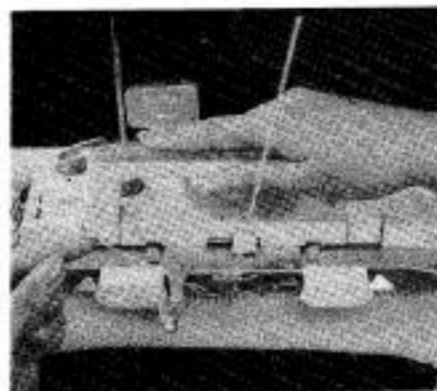

Fig. 52



---

When producing the pattern knitting, i. e. by inserting some pattern on the knit side with the contrasting colour as shown in Fig. 53, you should knit with only the main colour until you want to insert the pattern — at this point introduce the contrasting colour yarn to produce a pattern effect, and remove the contrasting colour at any desired point along the row according to the effect you wish to achieve.

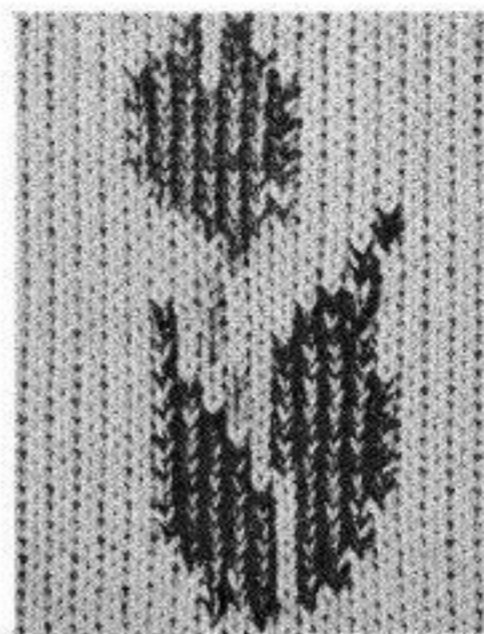

Fig. 53

**Note:** When knitting with Subsidiary Yarn Feeders, remember —

1. Always use the leading feeder, i. e. when moving the carriage from right to left, use left hand Subsidiary Feeder — and when moving the carriage from left to right use the right hand Sub-Feeder.
2. Never thread the wool through Overhead Yarn Feeder when knitting with Subsidiary Feeder, but always control and guide it with your left hand. (see Fig. 52)

---

## FANCY PATTERNS — USING THE SUB-KNITTER.

### The Sub-Knitter (see item 9 in illustration of Standard Accessories)

This accessory is used to speed up the knitting of special fancy patterns i. e. "Reversible Colour Knitting" and "Free Knit-in Colour Patterns" etc.

The Sub-Knitter, supplied with seven small weights, is used to bring forward the needles from position "C" into position "E" by moving it across the needles from **right to left**. It should be noted that the Sub-Knitter can **only** be used from right to left.

#### (1) Reversible Colour Knitting.

(This produces a contrasting colour pattern on the knit side of the fabric)

Reversible Colour Knitting, as referred to in the preceding paragraph, can be more easily obtained by use of the Sub-Knitter.

**SETTINGS :** Pattern Control Knobs at "M"  
Shifting Cam Lever at "C"  
Return Cam Lever at position 2

First fix one of the small weights on to the contrasting colour wool by trapping the wool between the plastic cap and the weight (Fig. 54). It is advisable to use a fine yarn.

**1st row** Thread the main colour into one of the Main Feeders with the carriage on the right. Place the Sub-Knitter on the rails of the needle bed at

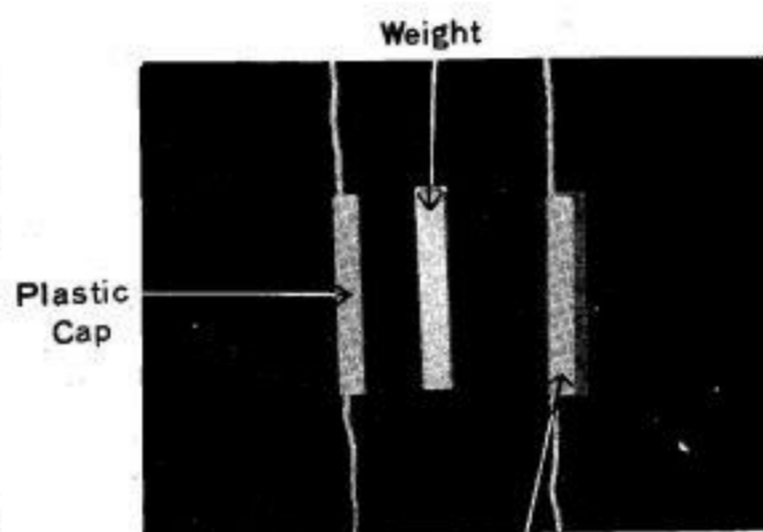

Fig. 54

Trapping the wool between the plastic cap and weight

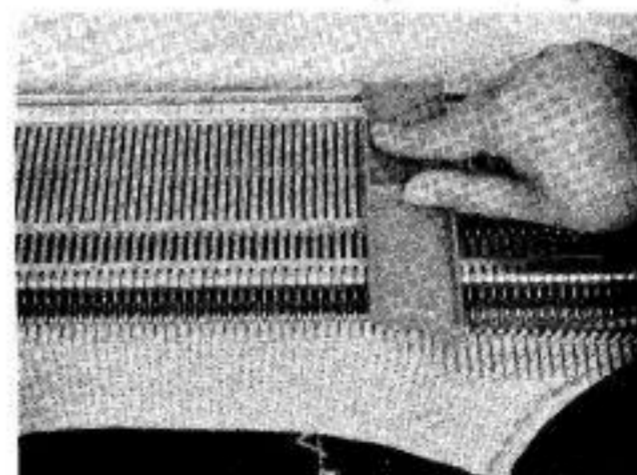

Fig. 55

the right hand end and slide it across the working needles from **right to left** (Fig. 55).

You will now see that all working needles have been brought forward into position "E". Make sure that all the loops of main colour are behind the open needle latches.

Make a loop in the end of the contrasting colour wool and hang this loop in the hook of the first needle at the right hand end of the pattern. Lay the contrasting colour wool in the hooks of those needles required for your pattern — working from right to left and then slide the weight down the wool until there is sufficient length of wool between the last needle and the weight for knitting the row. (Fig. 56).

Gently pull the fabric forward until all the latches are closed, move the carriage slowly across the needles to knit this row.

**2nd row** Carriage on left, using the Sub-Knitter as described for the first row bring the needles forward into position "E". Slide the weight down the contrasting colour wool and lay the wool into the required needle hooks from left to right (Fig. 57). Pull fabric forward to close the needle latches. Knit this row by moving carriage across to the right. (Fig. 58)

**NOTE:** The weights must always be at the opposite end of the knitting to the carriage.

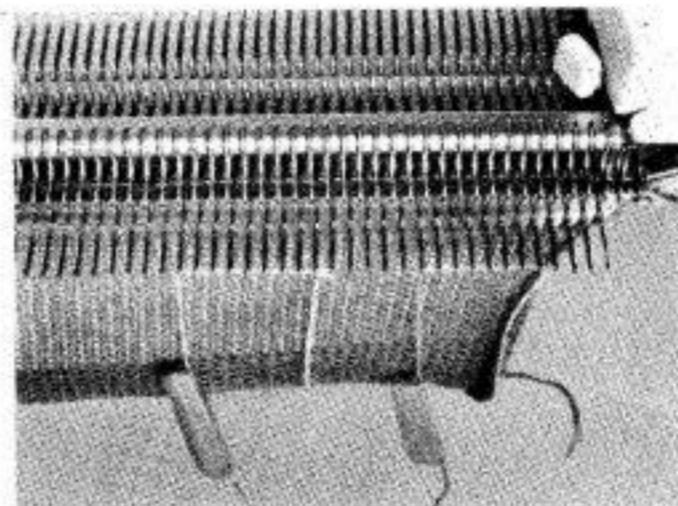

Fig. 56

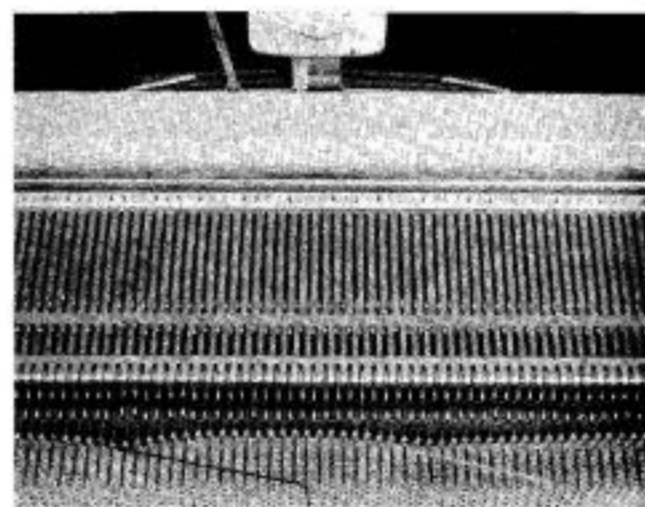

Fig. 57

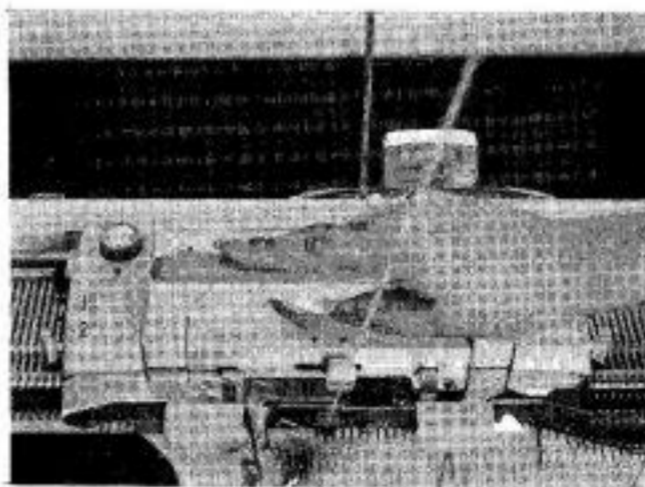

Fig. 58

---

## (2) Free Knit—in Colour Pattern.

This is Fancy Colour Knitting using two or more colours in the same row of stocking stitch. (Fig. 59) The same pattern appearing on both sides of the fabric.

**SETTING :** Pattern Contrhl Knobs at "M"  
Shifting Cam Lever at "C"  
Return Cam Levers in position 2

**NOTE :** The machine feeders are NOT used for this type of knitting.

When you reach the point in your knitting where it is intended to introduce the pattern, finish with the carriage on the right end —

- 1st row** (a) Break the wool and remove it from the Main Feeder. Pull both Feeders out of action.  
(b) Fix one of the small weights on the end of each colour of wool to be used. (Fig. 54)  
(c) Using the Sub-Knitter, bring forward into position "E" all the working needles. (Fig. 60)  
(d) Starting at the right hand end, make a loop in the end of the first colour and hang the loop in the hook of the needle in position "E" nearest the carriage. Slide the weight down the wool and, working to the left, lay the wool in the hooks of those needles required for the pattern, leaving sufficient wool between the last needle and the weight for the knitting of these stitches.

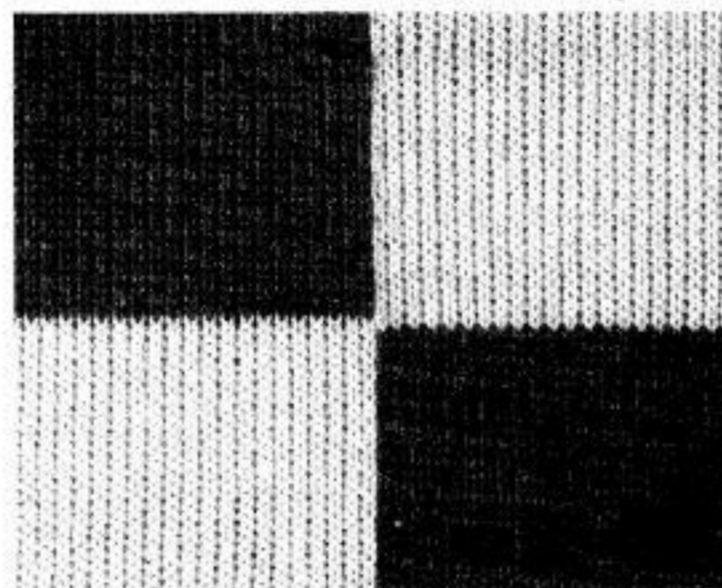

Fig. 59

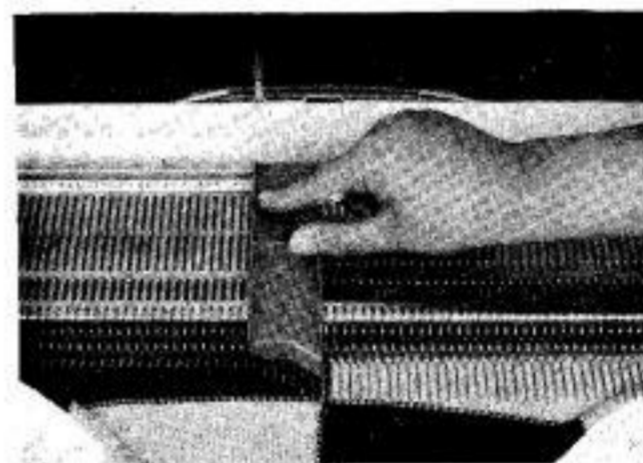

Fig. 60

(e) Starting with the next empty needle, i. e. the needle next to the one supporting the weight, proceed as in (d) using the second colour.

(f) When all the needles have a strand of wool in their hooks, gently pull the fabric forward until all the needle latches are closed. (Fig. 61) Move the carriage slowly across to the left to knit this row. (Fig. 62)

**2nd row** (g) Carriage on left, using the Sub Knitter, bring forward all the working needles into position "E".

(h) Starting on the left, slide the weight nearest the carriage down the wool and lay the wool in the required number of needle hooks.

(i) Slide the next weight down and, passing the wool behind the previous strand (Fig. 63) so as to form a loop round it, place this colour in the required number of needle hooks.

(j) When all the needles have a strand of wool in their hooks, gently pull the fabric forward until all the needle latches are closed. Move the carriage slowly across to knit this row.

Repeat from (c) to (j) until the pattern is completed.

**NOTE :** When changing colour in a row of knitting, the strands of wool must be passed round each other as shown in Fig. 63 to avoid making a hole in the fabric.

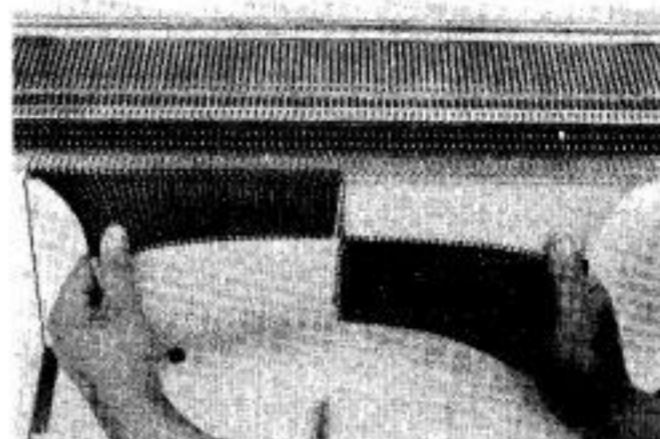

Fig. 61

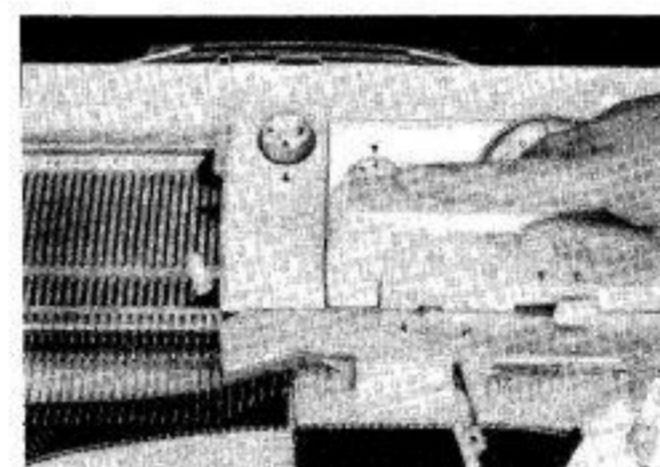

Fig. 62

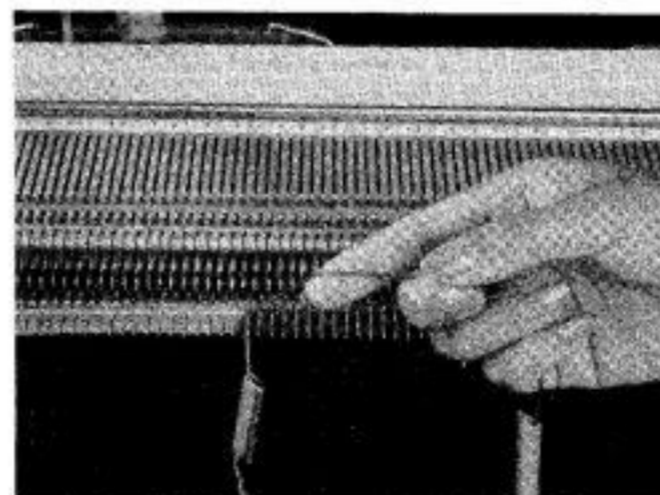

Fig. 63

---

## FANCY PATTERNS USING "VERTICAL PATTERN KNITTER"

You can obtain a variety of extra fancy pattern effects by using the unique "Vertical Pattern Knitter".

### 1. Vertical Pattern (Figs. 64 & 65)

- (a) Loosen the securing nut and remove the cover of the Vertical Pattern Knitter. (Fig. 66) Put the required number and lengths of contrasting colour yarn into each slot of the Vertical Knitter as shown in Fig. 66. Replace the cover and secure it by tightening the nut.



Fig. 64

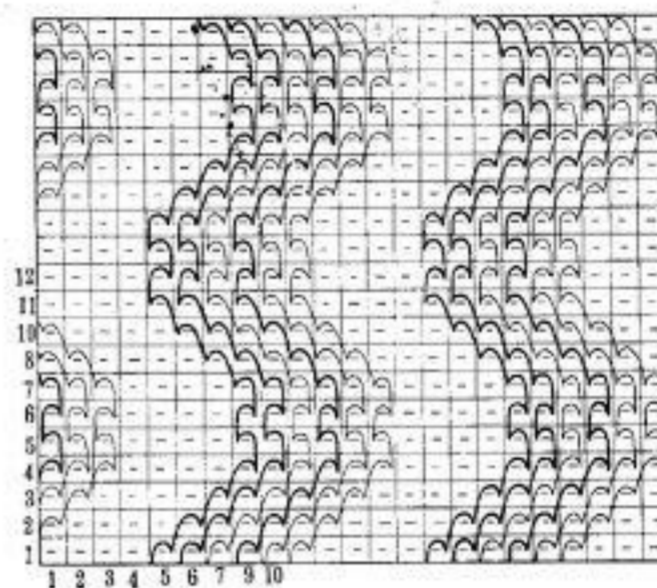

Fig. 65

- (b) Set the Pattern Control Knobs to "M", Shifting Cam Lever in either "T" or "C" and the Return Cam Levers in Position "2".
- (c) Hook each loop onto every alternate needle hook. (Fig. 67)
- (d) Bring forward into Position (E) every working needle and knit one row. (Fig. 68)
- (e) Raise the Vertical Pattern Knitter as shown in Fig. 69 and hook each strand onto its adjacent needle **on the left**.

(Fig. 70)

Knit 2nd row.

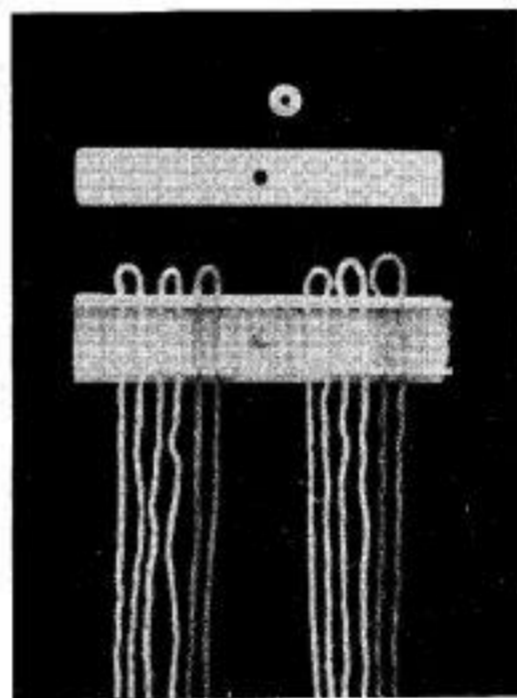

Fig. 66

- (f) Continue to knit until 4th row in just the same manner as described in (e) above.
- (g) Before knitting the 5th row hook each strand onto its adjacent needle **on the right**.
- (h) Hook each strand onto its adjacent needle **on the left** and knit the 6th row.
- (i) Hook each strand onto its adjacent needle **on the right** and continue to knit until the 11th row. (Fig. 71)

Repeat this procedure from (e) above.

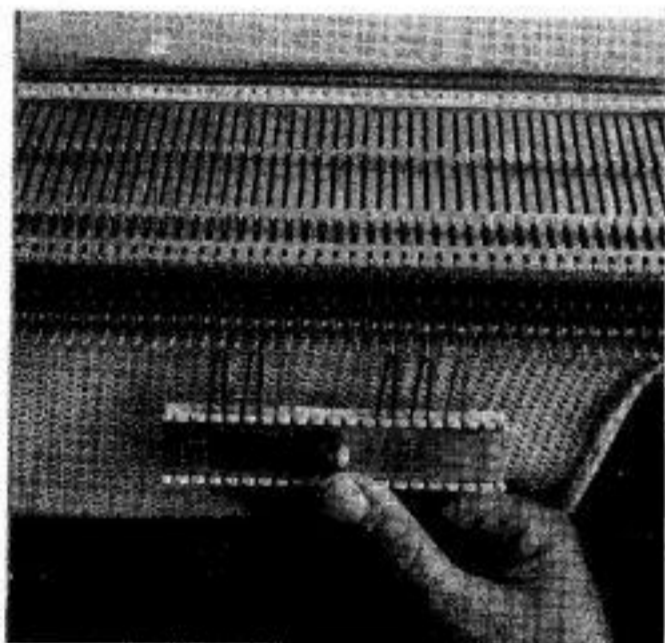

Fig. 67

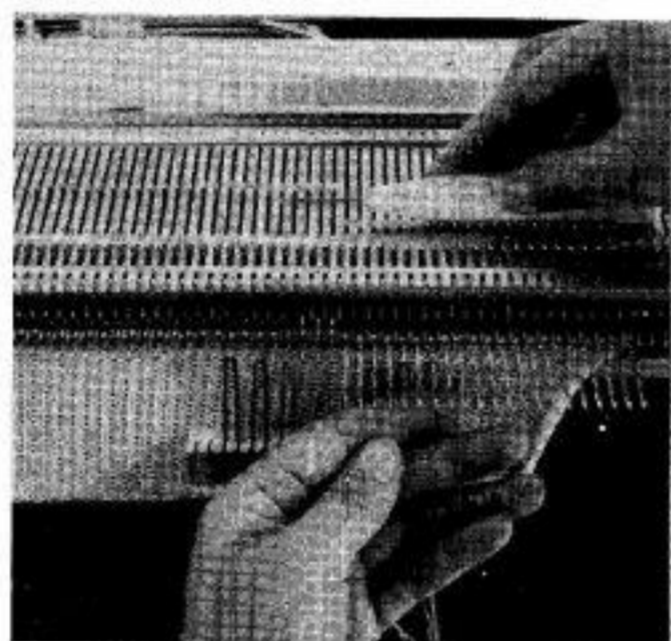

Fig. 68

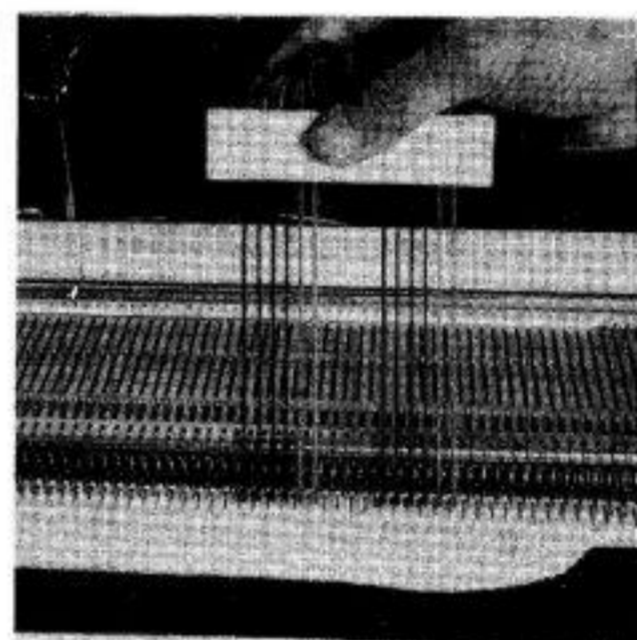

Fig. 69

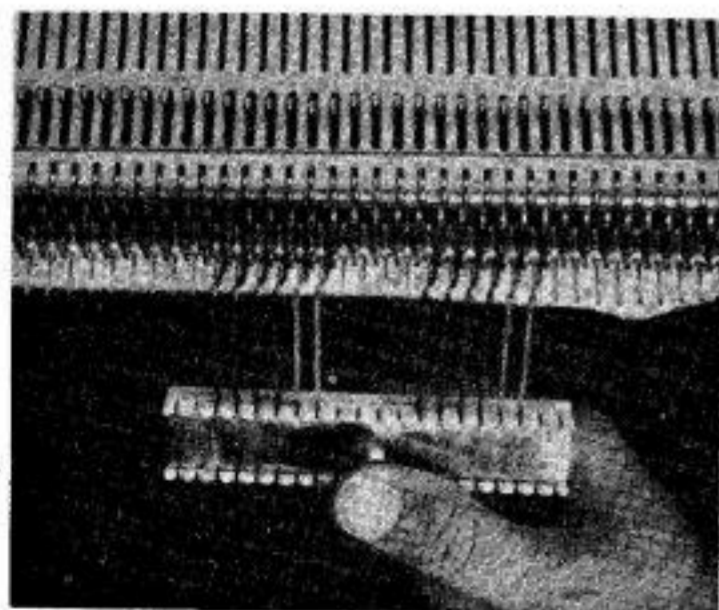

Fig. 70

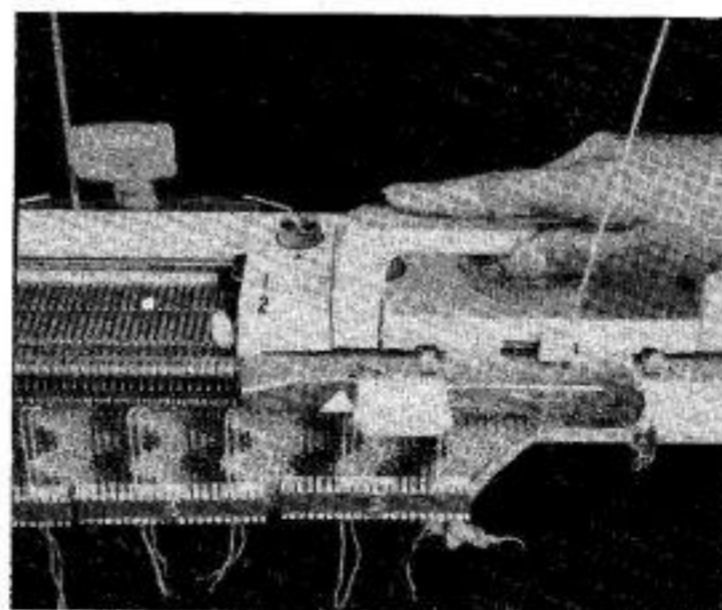

Fig. 71

---

## 2. Carpet Effect Knitting (Fig. 72)

- (a) Put the required number and length of contrasting colour wool, preferably thicker wool, into each slot of the Vertical Pattern Knitter in the same manner as described in preceding paragraph.
- (b) Set Pattern Control Knobs to "M", Shifting Cam Lever at "C", and Return Cam Levers in Position 2.
- (c) Hook each loop onto every alternate needle hook.
- (d) Knit one row simply moving the carriage from right to left.
- (e) Place a piece of Needle Selection Guide Strip just below and along the sinker hooks holding it with your left hand as shown in Fig. 73.
- (f) Raise up the Vertical Pattern Knitter as shown in Fig. 74 and hook each strand onto each adjacent needle on the right.

**NOTE :** According to the thickness of strip being applied, such as two strips together, the size of each loop will be changed.

- (g) Carriage on left. Knit three rows, simply moving the carriage back and forth.

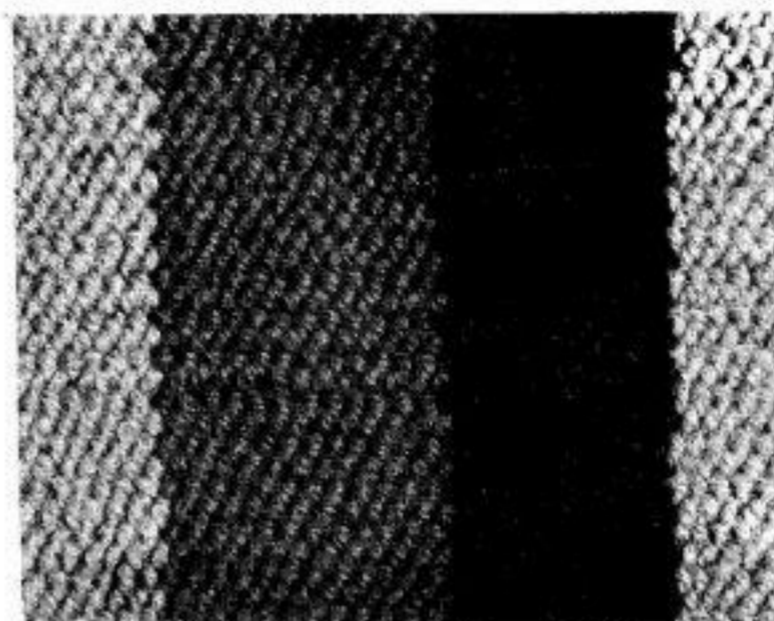

Fig. 72

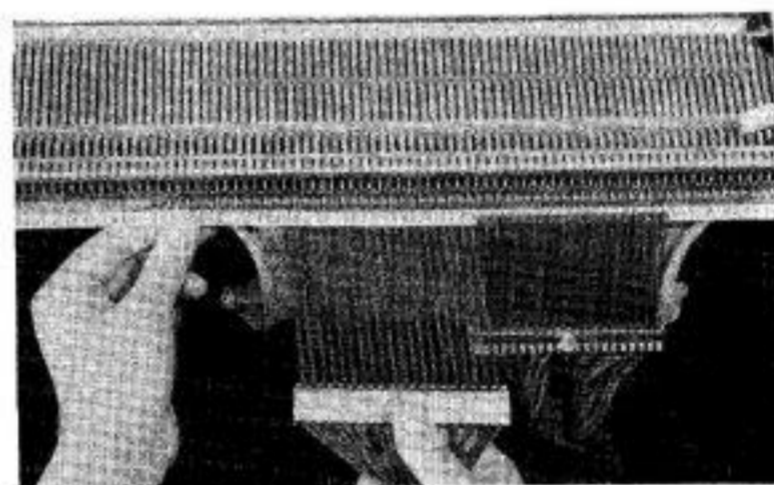

Fig. 73

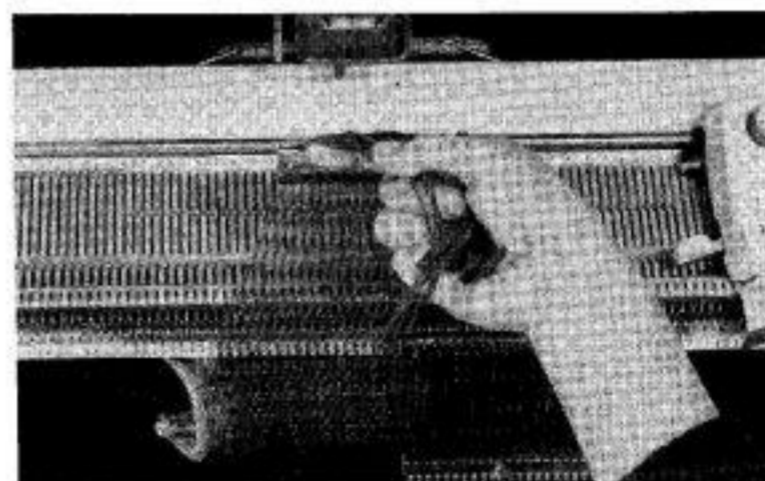

Fig. 74



- (h) Carriage now on right. Pull out the Needle Selection Guide Strip. Again place the Strip just below and along the sinkers—see Fig. 73. In the same manner as described in (f) above, hook each strand onto its adjacent needle on left. Knit three rows. Repeat the above procedure.

### 3. Bead Knitting (Fig. 75)

- (a) Thread beads on to a series of strands of cotton.

Lay the strands into the grooves of a Vertical Pattern Knitter, see Fig. 66.

Ensure that all beads are between the loop ends of the cotton and the Vertical Pattern Knitter as in Fig. 76.

Replace cover and secure firmly with the nut.

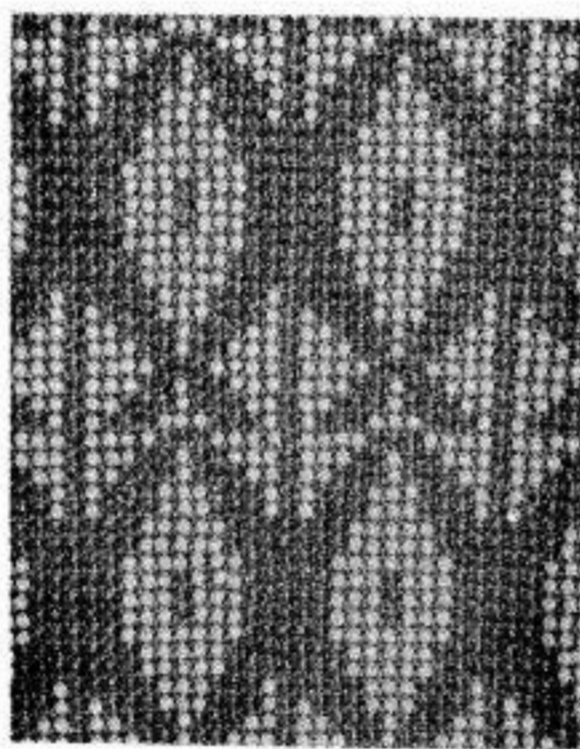

Fig. 75

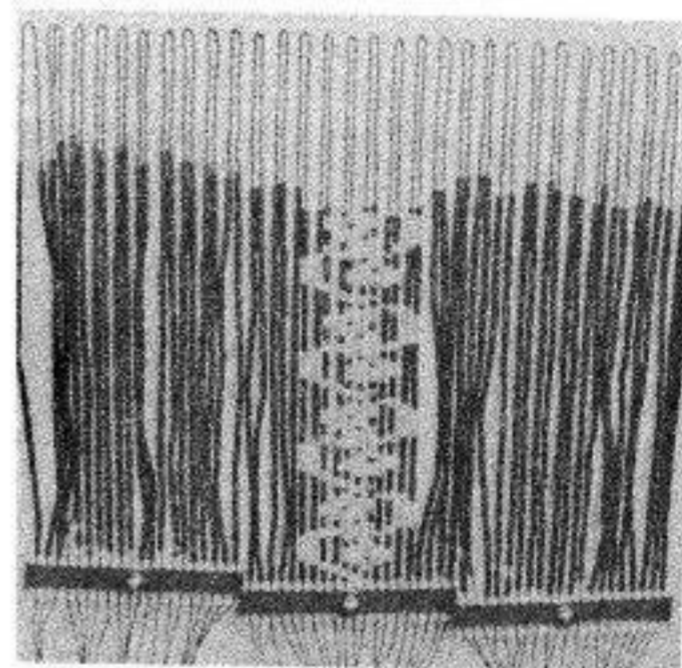

Fig. 76

- (b) Place each loop of the cotton into the hook of **alternate** working needles along that section of the work where the bead patterning is to be introduced. (Figs. 77 & 78)

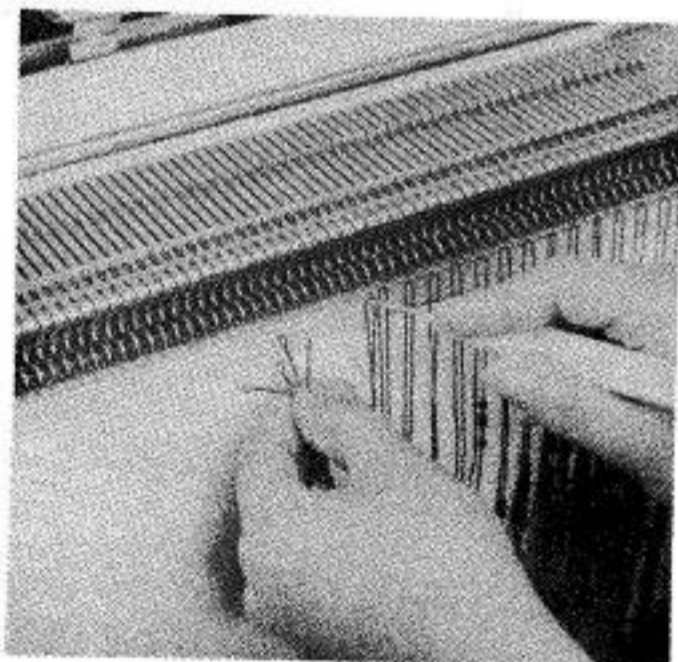

Fig. 77

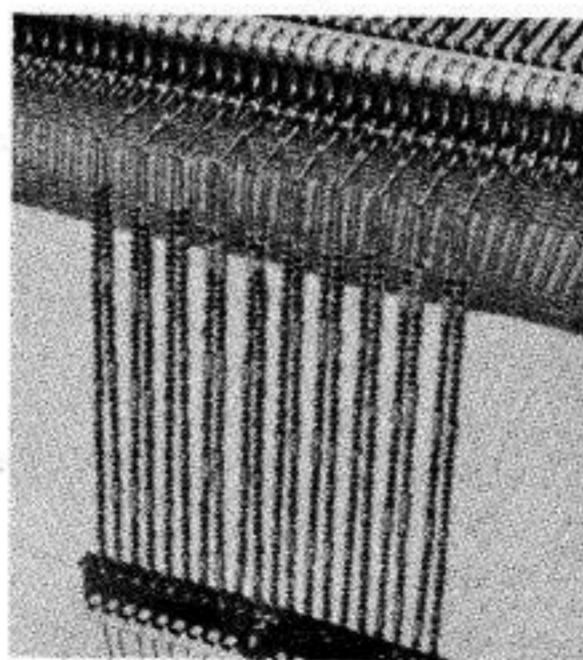

Fig. 78

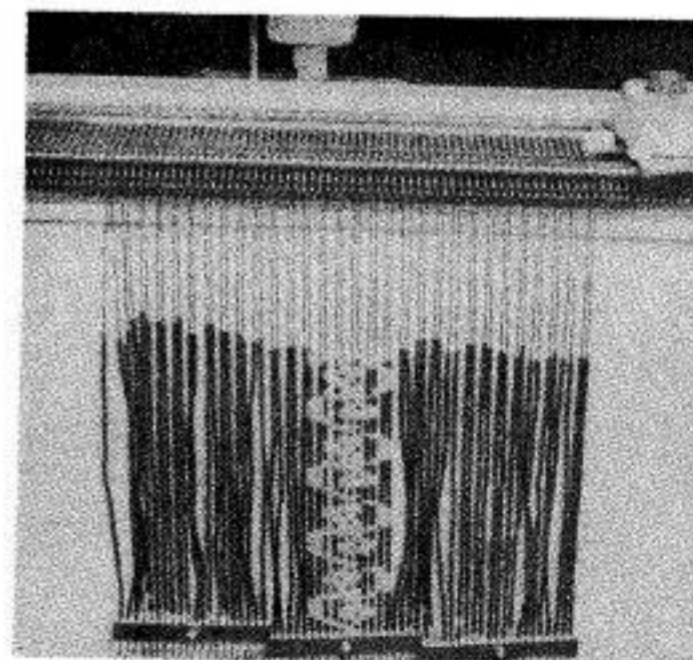

Fig. 79

- 
- (c) With Carriage on the right and the leading Return Cam Lever at 2 bring forward ALL the working needles into position (E). Knit one row by moving the Carriage from right to left. (Fig.79)
- (d) Raise the Vertical Pattern Knitter as shown in Fig. 69 and place each strand of cotton into the hook of the adjacent needle to the **left** as you lower the Vertical Pattern Knitter. Knit this row by moving the Carriage from left to right.
- (e) Before knitting the 3rd row place the Sinker Stopper between the Sinker Needle Butts and the Front Runner Rail at a point immediately above the Vertical Pattern Knitter.

(see Fig. 85)

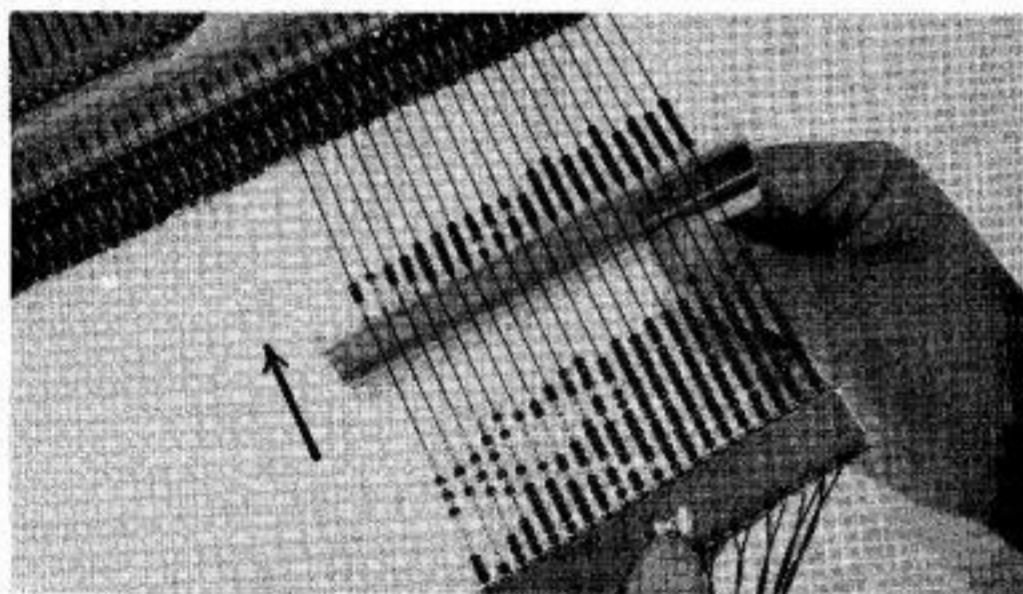

Fig. 80

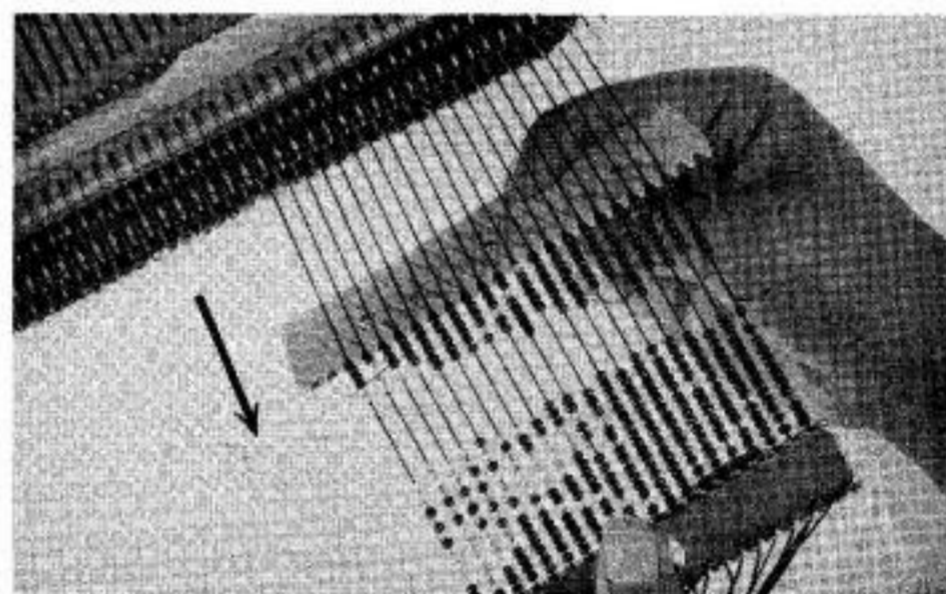

Fig. 81

Hold the Vertical Pattern Knitter with your left hand and the Bead Comb (Illustration "Standard Accessories Item No. 12) in your right hand. Separate a convenient number of beads from the rest and move them up to within an inch or so of the needles. (see Fig. 80) Align the top row of beads as shown in Fig. 81.

Now separate the top row of beads and move them up until they touch the underpart of the needle hooks. (see Figs. 82, 83 & 84)

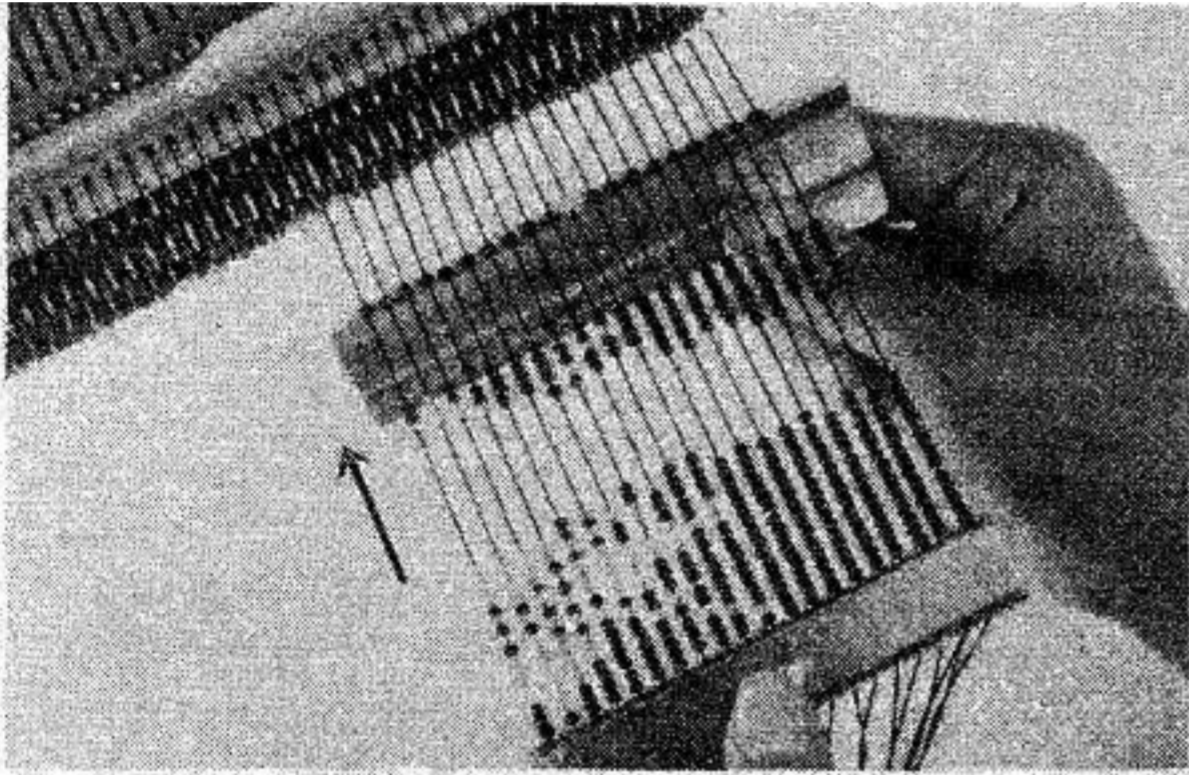

Fig. 82

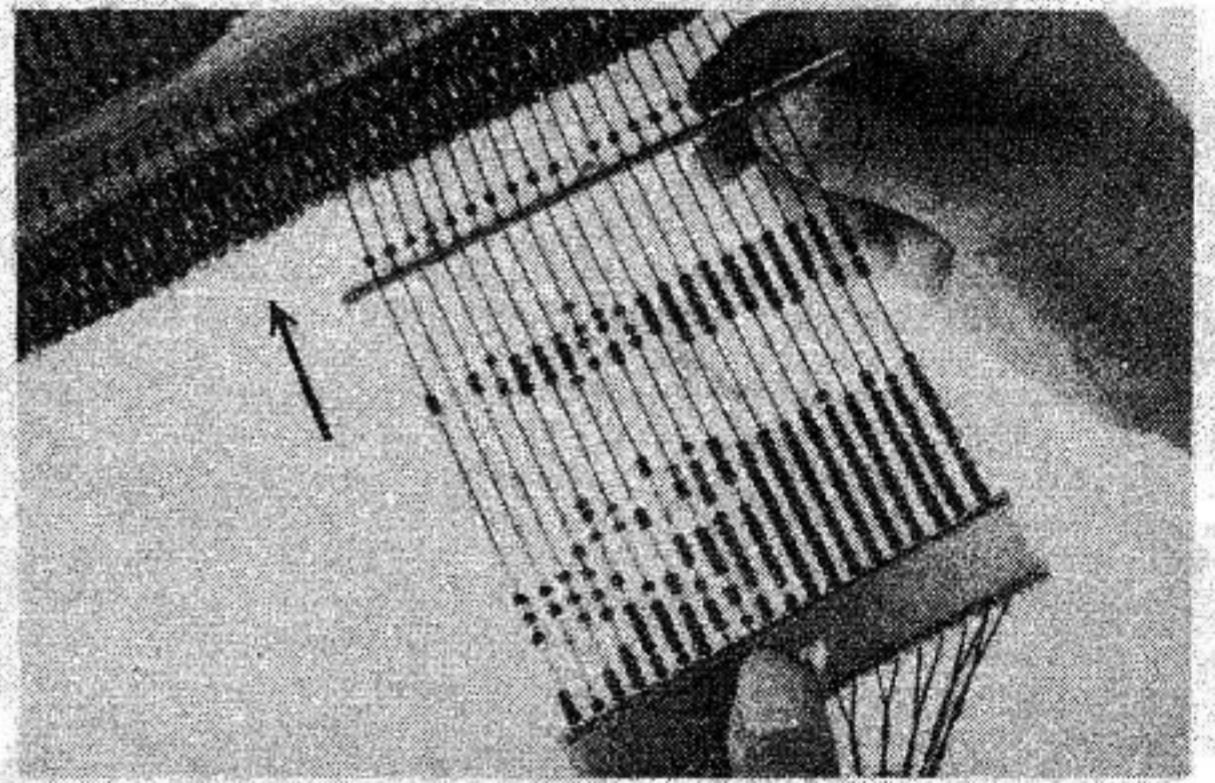

Fig. 83

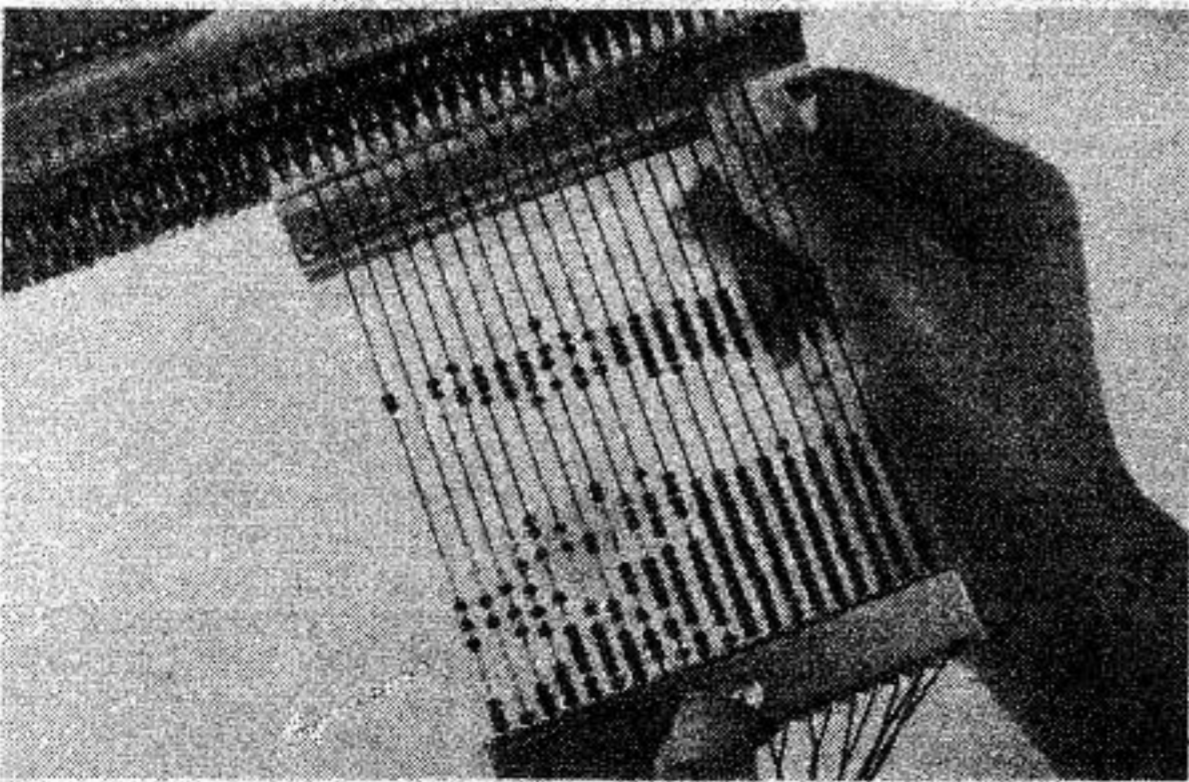

Fig. 84

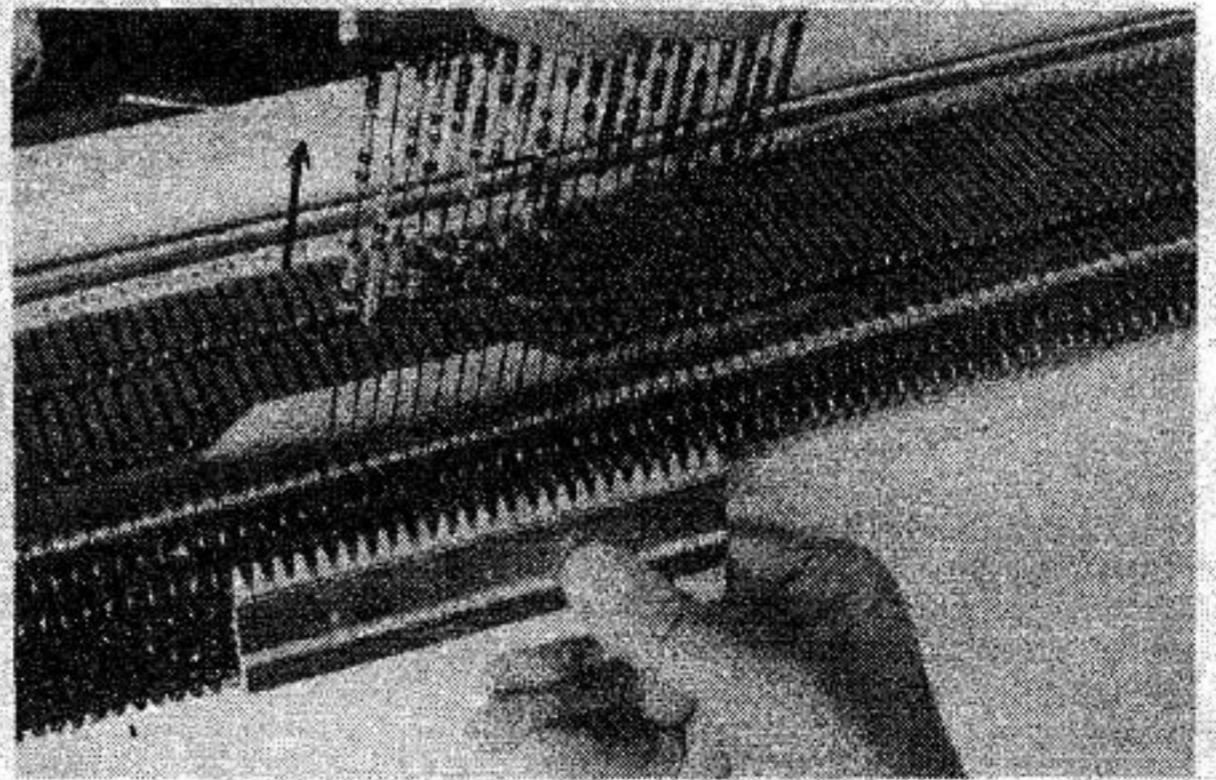

Fig. 85

Holding the beads firmly in this position with the comb, raise the Vertical Pattern Knitter and when it is above the needles move to the right so that when it is lowered the strands will each enter into the hook of the adjacent needle on the **right**. Do not forget to keep the strands reasonably taut whilst raising and lowering the Vertical Pattern Knitter. (see Figs. 85, 86 & 87) When the operation is completed the beads should be on the left of the needle hooks whilst the strands of cotton emerge from the right of the hooks as shown in Fig. 67. Remove the sinker stopper.

Knit this row by moving the Carriage from right to left.

Continue knitting by repeating (d) & (e).

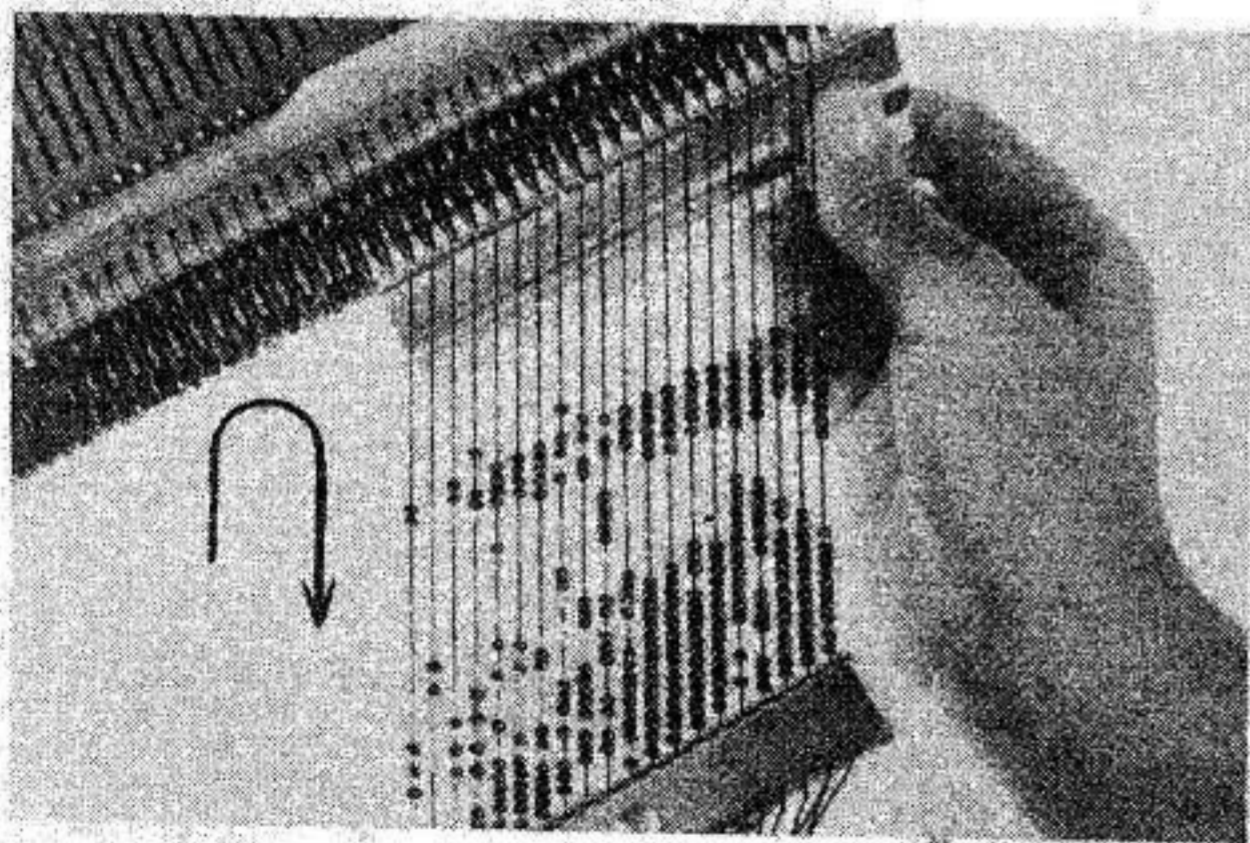

Fig. 86

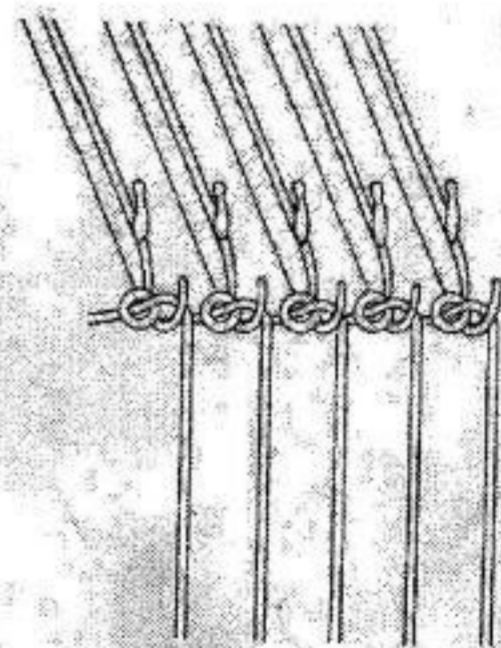
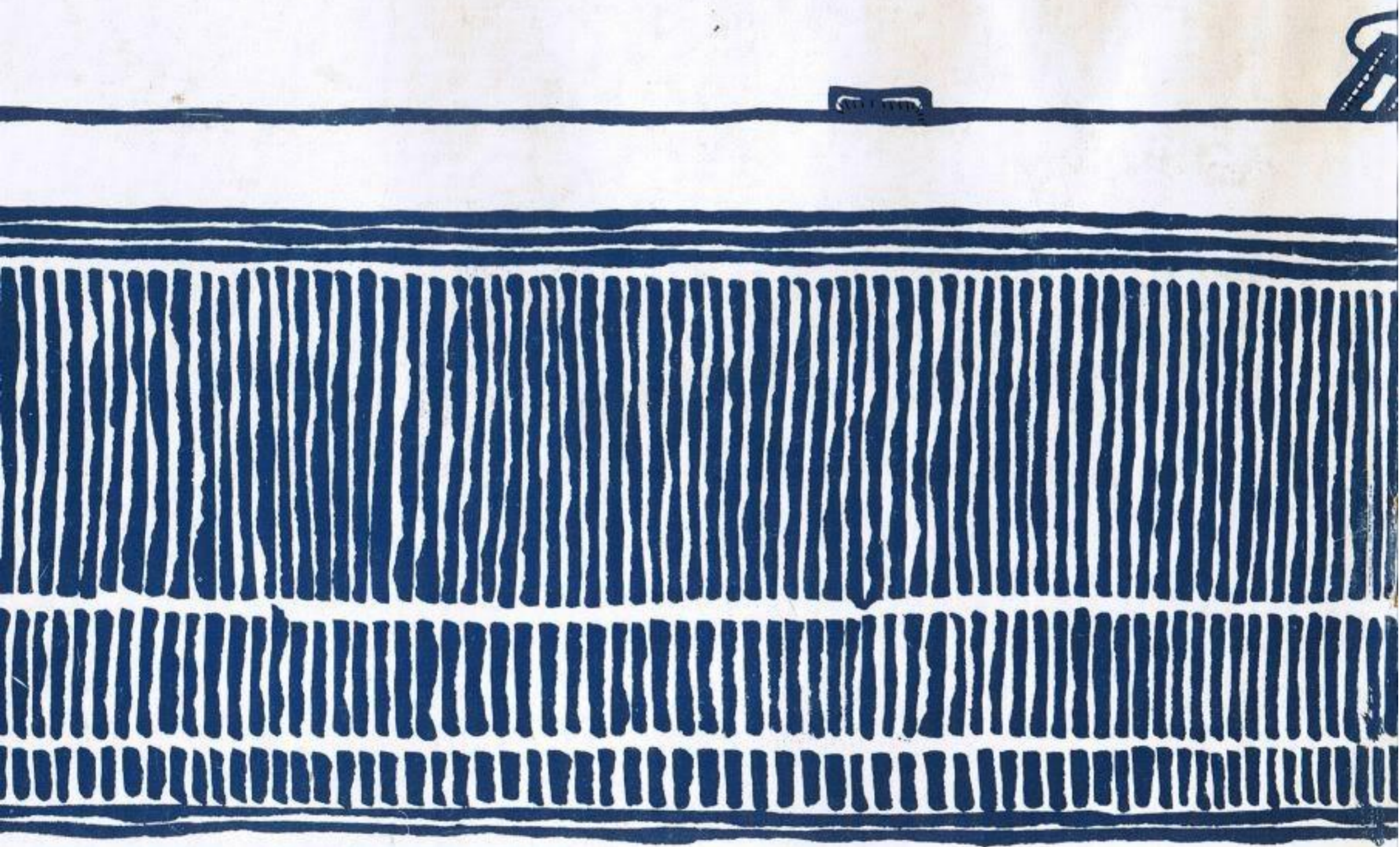

Fig. 87

MADE FOR **Genie**

BY CORONA KNITTING MACHINE CO., LTD.



PRINTED IN JAPAN