

---

**Model CH-1500 INSTRUCTION SHEET No. 1.**

**How To — OPEN THE MACHINE.**

**INSTRUCTION SHEET No. 1.**

1. Lift the machine out of its Carton.  
Place the machine along edge of table with Carrying Handle and Cover Fasteners at the back. (see Fig. 1)
2. Open both Fasteners (see Fig. 1).  
Lift Cover at the back about 1" clear of base and draw towards you to remove. Manipulate gently to clear contents. (see Fig. 2)
3. Turn Cover upside down with overhang at the back and place on table behind machine.
4. The large plastic Accessories Box on left of Needle Bed should be removed by lifting slightly at front with a backward and upward movement.  
Remove all other items on Needle Bed except Carriage on right.
5. With fingers of both hands resting on Carriage cover at each side of Carriage Handle raise the Handle by levering upwards with both thumbs. (see Fig. 3)
6. Unscrew and remove Plastic Knob of the Carriage Locking Plate (see Fig. 4)  
Note carefully how the Locking Plate is positioned as the Carriage must always be secured by the Locking Plate before replacing the Cover)
7. Insert into the right hand Cover-Fastener-Socket on the back edge of the machine the Wire Leaflet Holder (see Fig. 5)

Now, Place in this Wire Leaflet Holder.

INSTRUCTION SHEET No. 2.

for the next stage.

FIG. 1.

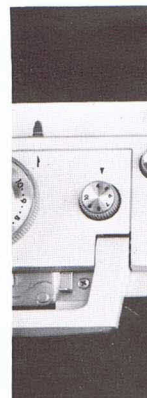

# Model CH-1500

FIG. 1.



FIG. 2.

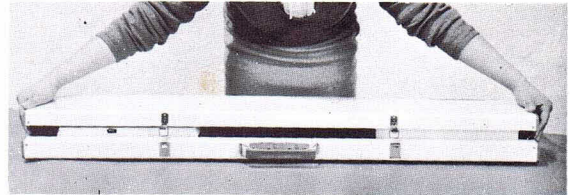

ROW-COUNTER  
TRIP LEVER.  
TENSION DIAL.

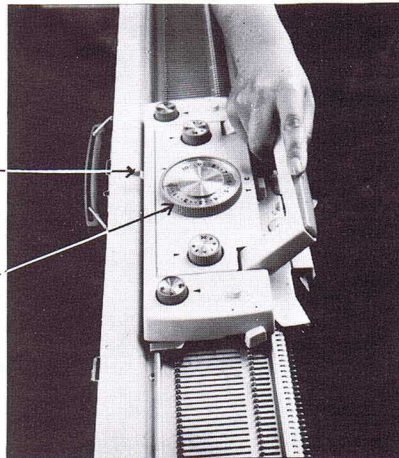

FIG. 3.

FIG. 4.

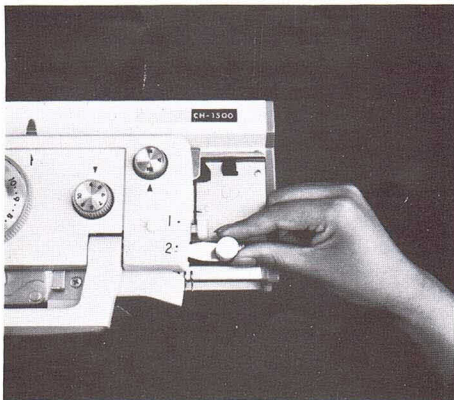
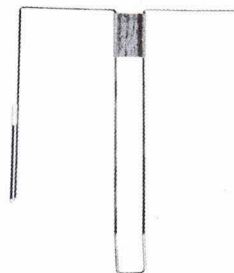

FIG. 5.



ners at the  
Manipulate  
achine.  
ing slightly  
Handle raise  
be secured  
e the Wire

**Model CH-1500 INSTRUCTION SHEET No. 2.**

**How To — ASSEMBLE THE MACHINE.**

**INSTRUCTION SHEET No. 2.**

1. From inside Machine Cover remove the Overhead-Feeder-Unit and Rod after releasing Wire Clips (see Fig. 1)
2. Into the small Socket under the Carrying Handle at the back of the Machine, insert the square end of the Rod in such way that the Rod leans backwards and the flat end is at the top. See Fig.2. (3) (see Fig. 2—③).
3. Fit the Overhead-Feeder-Unit to the top of the Rod so that the short Yarn-Trap-Wires extend to the front (see Fig.2—②).
4. About 6" from the top of the Rod clip the Yarn-Guide-Wire to the Rod so that the 3 eyelets extend to the back at right angles to the machine (see Fig. 2—④). (The Y-G-W. is in Accessories Box.)

5. Into the larger Socket adjoining the Socket for the Rod insert the Row Counter, which you will find in the plastic Accessories Box, (see Fig. 2—⑥).
6. Clip the plastic Hand-Tool-Holder to the Rod at a convenient height (see Fig.2—⑤). (The Hand-Tool-Holder will also be found in the Accessories Box.)
7. the following Hand Tools will be found wrapped in a soft plastic holder bag in the Accessories Box select these Tools and place them in the Holder as in Fig.2—⑤. :

- Needle Selector Plate ..... Fig. 3.
- Transfer Tool 2 x 1 ..... " 4.
- Crochet Needle ..... " 5.
- Sinker Stopper ..... " 6.



FIG. 3.



FIG. 4.



FIG. 5.



FIG. 6.

Now, Place in the Wire Leaflet Holder  
**INSTRUCTION SHEET No. 3.**  
 for the next stage.

FIG. 1.

- (1) SPRING
- (2) YARN-
- (3) ROD.
- (4) YARN-
- (5) PLAST
- (6) ROW-C
- (7) WIRE-I
- (8) CARRI
- (9) NEEDL

# Model CH-1500

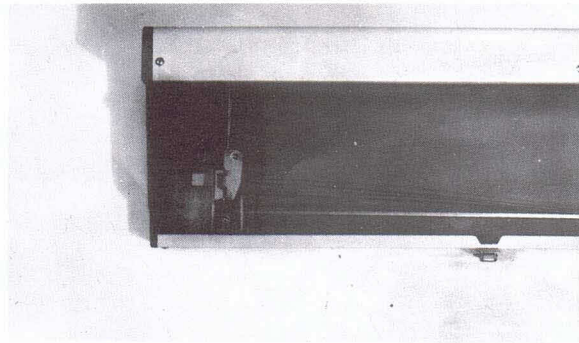
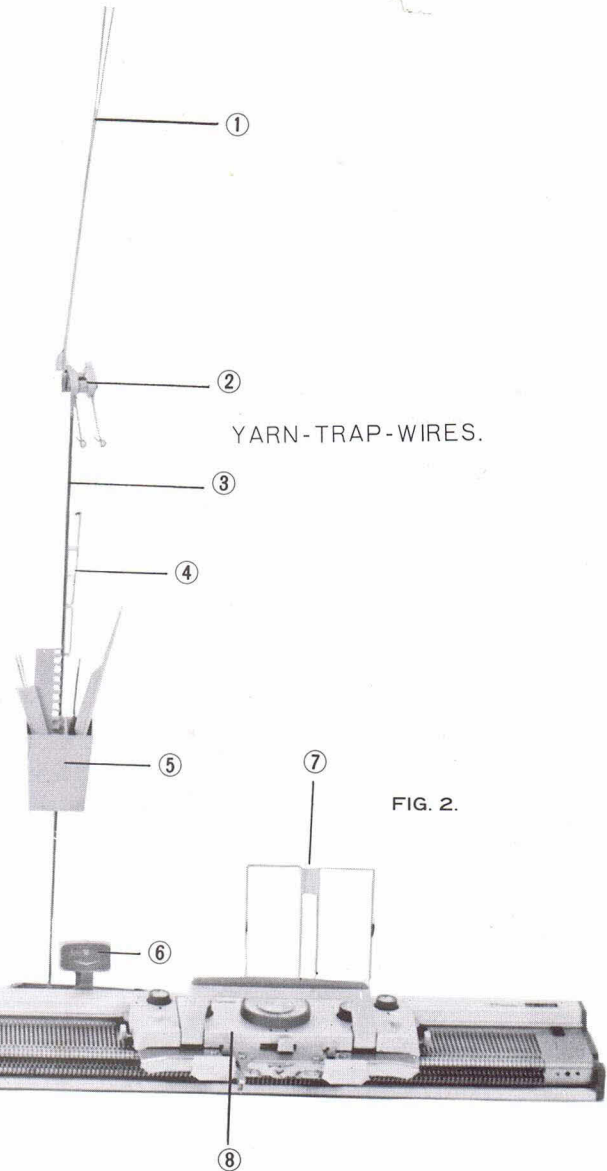

FIG. 1.

FIG. 2.

- (1) SPRING TAKE-UP WIRES.
- (2) YARN-TRAP.
- (3) ROD.
- (4) YARN-GUIDE-WIRE.
- (5) PLASTIC HAND-TOOL-HOLDER.
- (6) ROW-COUNTER.
- (7) WIRE-LEAFLET-HOLDER.
- (8) CARRIAGE.
- (9) NEEDLE-BED.



Socket  
, which  
essories

to the  
.2-⑤).  
e found

e found  
g in the  
ols and  
2-⑤). :

ig. 3.  
4.  
5.  
6.



**Model CH-1500 INSTRUCTION SHEET No. 3.**

**How To — CAST-ON WITH 2. 3. or 4 Ply WOOL.**

**INSTRUCTION SHEET No. 3.****HOW TO CAST-ON USING 2, 3, or 4 PLY WOOL**

(To Cast-On and Knit with Double Knitting Wools see separate Sheet.)

1. Adjust the position of the Needle-Selection -Guide-Strip (see Fig. 1)  
(Push the Strip at either end to bring the number 1 at the extreme Right Hand End of the Strip EXACTLY opposite the First Needle Groove at that end of the Needle Bed.)
2. Turn BOTH Knobs on the Carriage marked M.A.S. so that "A" is opposite the pointer (see Fig. 2)
3. PRESS DOWN and TURN BOTH Needle-Selection-Control-Knobs on the carriage to bring "4" opposite the pointer (see Fig. 2)
4. Turn the Tension Dial (large Dial in centre of Carriage) to No. 1.
5. Move the "T.C." Lever to the Right opposite "C" (see Fig. 3)
6. Take the Needle-Selector-Plate from the Hand-Tool-Holder.

In the centre of the Needle Bed draw forward 40 Needles from No. 20 on left of centre "0" to 20 on right of "0" (see Needle Numbering Rail Fig. 1) using the straight edge of the Selector-Plate. Align the Needles in Position "C" on Needle-Bed. (see Fig. 1.) Needles in Position "C" are known

as Working Needles.

7. At the Right Hand end of the Working Needles push back into position "B" on the Needle Bed two Needles opposite Nos. 4. & 6. on the Needle-Guide-Strip. (see Fig. 2.)
8. pull out of action the Left Hand Carriage Yarn Feeder (see Fig. 3.) Commence threading up the wool from the ball on the table at the back of machine by passing it up through the eyelet in the Yarn Guide Wire (see Fig. 4) Now raise the Yarn Trap Unit, lay wool across the base of the trap (see Fig. 5 (B) and lower the Trap Unit. Thread it through the eyelet at the end of the yarn Trap Wire (see Fig. 6(C) and also through the eyelet at the end of the long Take-up wire (see Fig. 7 (D) Now take it down to and thread through Right Hand Carriage Yarn Feeder (see Fig. 3(E).
9. Hold loose end of wool below Carriage-Feeder with Left Hand (see Fig. 3). Move Carriage Slowly to left until Right Hand End of Carriage is just clear of the end Working Needle on the Left. (1st. Casting-on Row)
10. At the Left Hand End of the Working Needles Push back into Position "B" on the Needle Bed the two Needles opposite Nos. 5. & 3. on the Needle-Guide-Strip. Keep hold of loose end of wool and move Carriage back to the Right of the Working Needles. (2nd. Casting-on Row)

FIG. 1  
NEEDLENEEDLE  
FIG. 2

FIG. 3



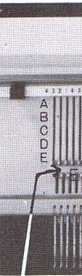
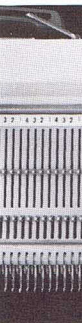

# Model CH-1500

the Working  
 on "B" on the  
 site Nos. 4. &  
 (see Fig. 2.)  
 and Carriage  
 Commence  
 the ball on the  
 by passing it  
 Yarn Guide  
 use the Yarn  
 the base of the  
 er the Trap  
 yelet at the  
 see Fig. 6(C)  
 at the end of  
 g. 7 (D) Now  
 rough Right  
 see Fig. 3(E).  
 ow Carriage-  
 ig. 3). Move  
 Right Hand  
 of the end  
 1st. Casting-  
 the Working  
 on "B" on the  
 opposite Nos. 5.  
 p. Keep hold  
 ove Carriage  
 king Needles.

FIG. 1.  
NEEDLE-SELECTION-GUIDE-STRIP

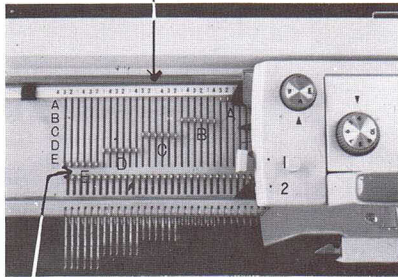

NEEDLE-NUMBERING-RAIL.

FIG. 2.

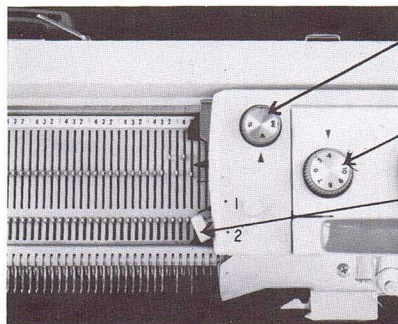

M. A. S. Knob.  
 NEEDLE-SELECTION-CONTROL-KNOB.  
 RETURN-CAM-LEVER

FIG. 3.

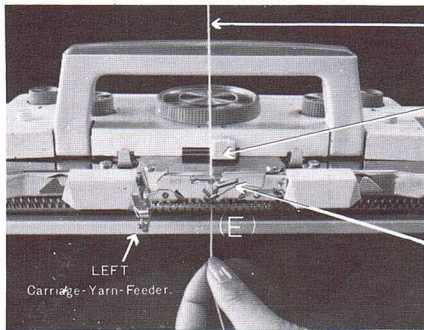

Wool from Overhead-Feeder-Unit.  
 T.C. Lever.  
 RIGHT Carriage-Yarn-Feeder.

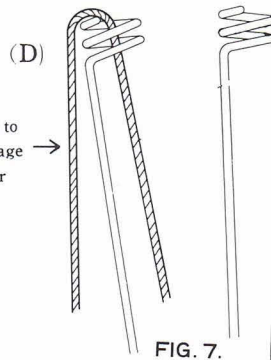

FIG. 7.

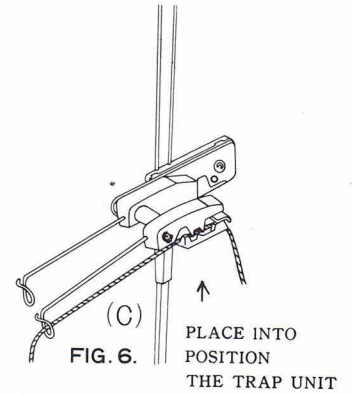

FIG. 6. PLACE INTO POSITION THE TRAP UNIT

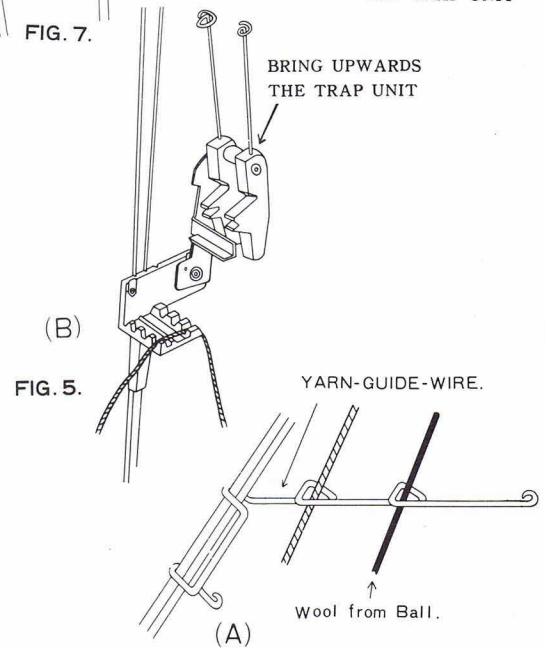

FIG. 5.

11. These two Rows Complete the Casting-On. Now, Place in the Wire Leaflet Holder INSTRUCTION SHEET No. 4 for the next stage.

**Model CH-1500    INSTRUCTION SHEET No. 4.**

**How To — KNIT, FORM A HEM, INCREASE,  
and DECREASE.**

## INSTRUCTION SHEET No. 4.

1. Having knitted the 2 Casting-on Rows turn the Tension Dial to the appropriate setting for the thickness of wool being used :  
 For 4 ply wool Turn Tension Dial to No. 8.  
 " 3 " " " " " " No. 5.  
 " 2 " " " " " " No. 3.
2. Turn BOTH M.A.S. Knobs to "M" opposite the pointer.
3. Pull FORWARD to position 2. BOTH Return-Cam-Levers (Sheet 3. Fig. 2)
4. By means of the knobs at the back turn the Row Counter to "O.O.O."
5. Pull out towards back of machine the Row-Counter-Trip-Lever which you will find to the right of the Tension Dial along back edge of the Carriage.
6. Knit 30 Rows. (The Carriage must clear the last Working Needle at the end of each row.) When the Row Counter registers 30 the Carriage should be on the Right.
7. **TO FORM A HEM.** Insert the Sinker-Stopper in the channel between the Butts of the Sinker-Needles and the Front Rail of the Needle Bed (see Fig. 1). The Sinker-Stopper should be in that part of the channel immediately in front of the Working Needles.  
 Turn the knitting up towards you. With the pointed end of the Crochet Needle place

the series of Long Loops which you will find along the Cast-on Edge into the hooks of the corresponding Working Needles — one loop to a needle. With the side of your left hand with fingers outstretched push and hold the fabric back against the Sinkers (see Fig. 1) after all the long loops have been placed into the hooks of all the working needles. Holding back the folded hem as described, bring forward all the Working Needles into position "E" i. e. until the Butts are touching the Needle Numbering Rail. REMOVE THE SINKER-STOPPER. Now, push the Carriage slowly across to the Left to complete the Hem. Knit a further 3 rows finishing with the Carriage on the Right.

8. **TO INCREASE A STITCH.** Pull forward the next Empty Needle on the Right and bring it into line with the Working Needles. Knit one row by moving the Carriage across to the Left. Now, pull forward similarly an empty needle on the Left and knit the row by moving the Carriage back to the Right. You have Increased 1 stitch at each end. (Note, Always increase a stitch at the same end as the Carriage) .  
 Increase **one more** stitch on the right and knit **two** rows so that the Carriage will

again  
 9. **TO DI**  
 × 1 T  
 single  
 Working  
 Draw  
 Tool u  
 Latch  
 Now,  
 stitch  
 Tool (L  
 Lift th  
 the Ne  
 of the  
 handle  
 that th

FIG. 1.

FIG. 2.

Without  
 the corre  
 INSERT

# Model CH-1500

again be on the right.

9. **TO DECREASE A STITCH.** Take the 2 × 1 Transfer Tool. Place the Eye of the single needle into the hook of the End Working Needle on the Left. (see Fig. 2—①). Draw the Needle towards you with the Tool until the Stitch passes behind the Latch (see Fig. 2—②). Now, Push the Needle back until the stitch slips onto the needle of the Transfer Tool (see Fig. 2—③). Lift the Eye of the Transfer Tool out of the Needle Hook and place it into the Hook of the next Working Needle. Tilt the handle of the Transfer Tool upwards so that the Stitch can slide down the stem of

the Needle and into the machine needle hook when you give a gentle downward tug on the knitting immediately below (see Fig. 2—④).

Push the empty Needle, from which you have just transferred the stitch, to the back of the groove into Position "A". You have Decreased 1 Stitch on the Left.

10. Make sure that the Knitting is UNDER the SINKER HOOKS then knit 4 Rows without further Shaping, finishing with the Carriage on the Right. You should now find that you have 42 Needles in the Working Position from No. 20 on the Left to No. 22 on the Right.

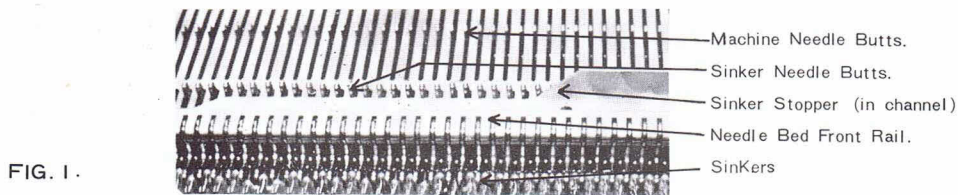

FIG. 1.

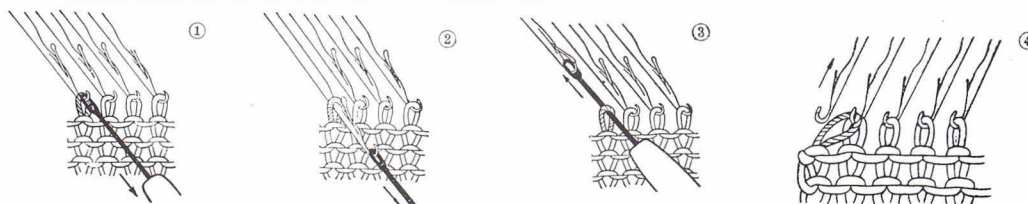

FIG. 2.

Without disturbing the knitting, transfer the Leaflet Holder from the Socket on the right to the corresponding Socket on the Left of the Machine Carrying Handle. INSERT INSTRUCTION SHEET No. 5. IN THE LEAFLET HOLDER READY for the next stage.



Model CH-1500 INSTRUCTION SHEET No. 5.

**How To Do—FANCY PATTERN KNITTING USING  
THE “PATTERN—MASTER”.**



## INSTRUCTION SHEET No. 5.

## PATTERN KNITTING WITH THE PATTERN-MASTER.

1. Assemble the Pattern-Master as explained on the Instruction Card which you will find in the Pattern Card Frame.
2. With Pattern Card No. 47 in position (see Fig. 1. overleaf) insert the Support Rod of the Pattern-Master in the right hand Socket at the back of the machine. Push fully home into the Socket.
3. Transfer the wool from the Right to the Left Carriage-Yarn-Feeder.  
With a Contrasting Colour wool thread-up the machine. Allow 10 or 12 inches of the wool to hang loosely below the machine after threading through the Right Hand Carriage-Yarn-Feeder.
4. **Bottom Row Windows of the Pattern-Master.** : The settings to be made **before** starting to knit the pattern appear at these Windows. The Settings for Pattern No. 47 you will find are as follow reading from Left to Right.
 

M.A.S. .... Setting: "A" .... Turn BOTH M.A.S. Knobs on Carriage to "A".

T.C.L. .... Setting: "C" .... Move the T.C.Lever at front of Carriage to "C".

N.S.C.K.

L/H. .... Setting: "6" .... Turn Left Hand Knob numbered 4-10 to "6".

R/H. .... Setting: "6" .... Turn Right Hand Knob numbered 4-10 to "6".

N.S.G.S. ... Setting: "6" .... Use the Needle-Selection-Guide-Strip numbered 1.2.3.4.5.6. repeating. Align the Strip so that the first number 1 on the right of the Strip is directly opposite the first Needle Groove at the right hand end of the Needle Bed.

O.L. .... Setting: "2" .... Use the number 2 Operating Lever of Pattern Master. This is the Lever extending from bottom centre of the Pattern Master. (see Fig. 1 overleaf)

5. **Top Row**  
at these  
the bot  
Pattern  
Pull ou  
Carriag  
Row of  
At the  
No. 1 o  
& 6. at  
Position  
moving
6. When  
change  
the sar  
Push B  
& 1. on  
moving
7. You wi  
appears  
action t  
row W  
Position  
(3rd. R
8. With C  
back t  
Strip.

## Model CH-1500

5. **Top Row Windows of the Pattern Master.** The Coloured and Black Blocks appearing at these Windows are the Pattern Knitting Instructions. With the Setting Instructions at the bottom row of windows the following can be seen at the Top Row of Windows for Pattern No. 47. R.Y.F. (Right-hand Yarn Feeder) Above these letters appears a Red Block. Pull out of action the Left Hand Carriage Feeder and flick into action the Right Hand Carriage Feeder against the front of the Carriage. Next in the Top Window above the Row of Numbers 1 to 10. you will see Black Blocks immediately above Nos. 1. 5. & 6. At the extreme right of the Working Needles you will find that the End Needle is opposite No. 1 on the Needle-Guide-Strip. Push this Needle and the Two Needles opposite Nos. 5. & 6. at the same end back into Position "B" leaving all the rest of the Working Needles in Position "C". Holding the loose end of wool below the Carriage Feeder knit the Row by moving the Carriage from Right to Left. (1st Row of Pattern)
6. When using the No. 2 Operating Lever of the Pattern Master the Window Readings only change every 2nd Row. Therefore, with the Carriage now on the Left the Readings remain the same as for the 1st Row. Leave the Right Hand Carriage Yarn Feeder in action and Push Back into Position "B" those Working Needles at the Left Hand End opposite Nos. 6. 5. & 1. on the Needle Guide Strip. Take hold of the loose end of wool again and knit this row moving the Carriage from Left to Right. (2nd. Row of Pattern)
7. You will see that the Blocks in the Top Row Windows have now changed. A Green Block appears above L. Y. F. Pull out of action the Right hand Carriage Feeder and flick into action the Left hand Feeder. Black Blocks now appear over numbers 2 and 4. in the top row Windows. Again at the Right hand end of the Working Needles push back into Position "B" two Needles opposite the first 2 and 4. on the Needle Guide Strip. Knit the row. (3rd. Row of pattern)
8. With Carriage on Left there is again no change in the Top Row Window Readings. Push back two Needles at the Left hand end opposite the first 4. and 2. on the Needle Guide Strip. Knit the row (4th. Row of Pattern)

(Please turn over)

9. With the Carriage on the Right there is again a change in the Top Window readings. Proceed by changing over Carriage Feeders as indicated and by pushing back at each end those Needles opposite the Numbers on the Guide Strip as shown by Black Blocks on the Pattern Master. Needles must be selected at the Carriage end of the Working Needles before knitting the row.

Where no Black Blocks appear in the Window no Needle Selections should be made, even so a Carriage Feeder Change may have to be made.

When a full row of Red Blocks appears in the Numbered Top Window this means you have reached the end of the Pattern.

Depress the Lever at the left side of the Pattern Master to return the Pattern Card for a repeat of the pattern.

10. To strip the knitting off the machine needles, break or cut the wool between the end needle and the Carriage Feeder and move the Carriage slowly across the Working Needles as though knitting a row.

**NOTE:** The Pattern will be seen on the "Knit" side of the fabric and not on the "Purl" side which faces you.

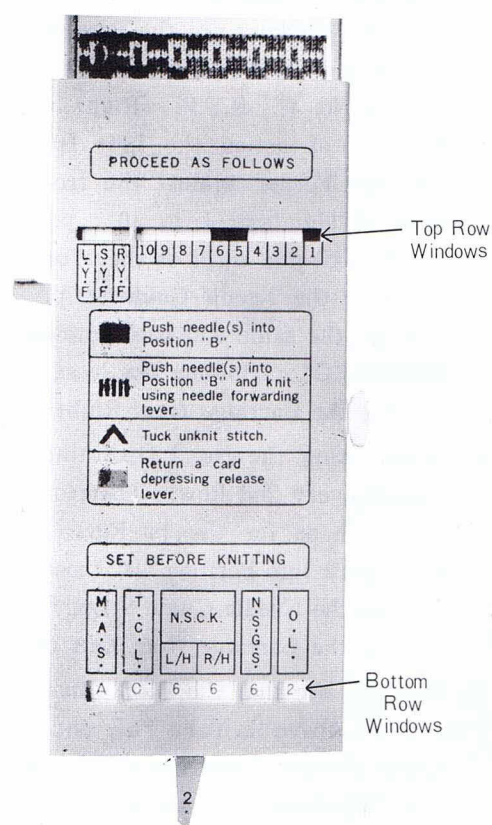

FIG. 1.

How T  
THE "

**Model CH-1500 INSTRUCTION SHEET No. 6.**

**How To — CAST-ON and KNIT WITH  
DOUBLE-KNITTING-WOOL.**



**INSTRUCTION SHEET No. 6.****HOW TO CAST-ON USING—DOUBLE KNITTING WOOL.**

(To Cast-on and Knit with 2, 3, or 4, ply wools see Instruction Sheet 3)

1. With Carriage on right, bring forward into Position "C" 40 Needles from No. 20 on left of centre "0" to No. 20 on right of centre "0".
2. Turn BOTH M.A.S. knobs to "A".
3. Turn BOTH N.S.C.K. knobs to "4".
4. Turn Tension Dial to No. 1.
5. Move T.C. Lever to "C".
6. Pull forward to Position 2. BOTH Return Cam Levers (see Fig. 1).
7. At the Right-Hand End of the Working Needles push back into Position "B" the 1st and the 3rd Needles.
8. Pull Out-Of-Action BOTH Carriage Feeders (see Fig. 1)
9. Take hold of the Carriage Handle, with the thumb pressing and holding in the Needle-Forwarding-Lever which is to the Left of the T.C.Lever. (see Fig. 1)
10. Move the Carriage across the Working Needles from Right to Left.
11. Push back into Position "A" the Needles remaining in Position "C".
12. Without depressing the Needle-Forwarding-Lever move the Carriage back to the Right.
13. Thread-up the machine with Double Knitting Wool.
14. Push back into Position "B" the extreme end Working Needle on the Right.
15. Holding the loose end of wool below the Carriage Feeder move the Carriage slowly from Right to Left.
16. At the Left-hand end of the working Needles push back into Position "B" the FIRST NEEDLE HOLDING A LOOP OF WOOL. Move the Carriage slowly back to the Right. This completes the Cast-On.

**To Continue Knitting :**

17. Turn the Row Counter to "0.0.0."
18. Change Tension by turning the Tension Dial to 8, 9, or 10.
19. Turn BOTH M.A.S. Knobs to "M" and continue to knit without any further selection of needles.



# Model CH-1500

forwarding  
back to the

Double

extreme  
ht.

below the  
age slowly

working  
"B" the  
LOOP OF  
ly back to  
Cast-On.

Tension

"M" and  
y further

