

# WHITE

THE SELECTION BOX



U.S.A.

Viking White Sewing Machine Company  
White Knitting Machine Division  
11750 Berea road  
CLEVELAND, OHIO 44111

CANADA

White Knitting Products  
1470 Birchmount rd.  
SCARBOROUGH, ONTARIO  
M1P 2G1

and:

White Knitting Products  
321 Levi st., Unit 1  
NEW WESTMINSTER, B.C.  
V3M 4N4

# SUMMARY

	PAGE
I THE SELECTION BOX . . . . .	4
● Main parts . . . . .	4-6
II CURSOR AND CURSOR STOPS . . . . .	7
III SETTING UP OF THE SELECTION BOX . . . . .	8
IV CURSOR POSITION ACCORDING TO TYPE OF KNITTING . . . . .	10
V USE OF THE DIFFERENT CONTROLS . . . . .	11
● Direction indicator of programme-card . . . . .	11
● Manual programme-card advance . . . . .	11
● Programme-changer . . . . .	11
● Decorative design adjustment dial . . . . .	11
● On and Off switch . . . . .	12
● Reverser . . . . .	12
● Row repeat switch . . . . .	12
● Automatic row advance stop/every other needle selector switch . . . . .	13
● Automatic programme-card advance/return switch . . . . .	13
● Card-return warning light (interacts with buzzer) . . . . .	13
● Programme-card insertion and alignment reference . . . . .	14
● Pattern scanners . . . . .	14
● Pattern-line indicator . . . . .	14
● Programme-card guide . . . . .	14
● Programme-card cover . . . . .	14
VI SETTING OF A DESIGN . . . . .	15
● Using geometric programme-card . . . . .	15
● Using decorative programme-card . . . . .	17
VII HOW TO USE THE SELECTION BOX WITHOUT PROGRAMME-CARD . . . . .	19
VIII HOW TO USE THE SELECTION BOX WITH GEOMETRIC PROGRAMME-CARD . . . . .	20
● Description of the geometric programme-card . . . . .	20-21
● Description of the programme-card cover . . . . .	21
● The use of the geometric programme-card . . . . .	22-23
IX HOW TO USE THE SELECTION BOX WITH DECORATIVE PROGRAMME-CARD . . . . .	24
● Description of the decorative programme-card . . . . .	24-25
● Description of the programme-card cover . . . . .	25
● Test sample . . . . .	26
● The use of the decorative programme-card . . . . .	27-30
X ILLUSTRATED PATTERN CHART . . . . .	31-32
XI SOME HINTS . . . . .	33-34
XII HOW TO KNIT . . . . .	35
● Tuck knitting . . . . .	35
● Slip stitch knitting . . . . .	35-36
● Fair Isle . . . . .	36-37
Single design in Fair Isle . . . . .	37-38
● Jacquard . . . . .	38
Method 1 . . . . .	38-39
Method 2 . . . . .	39
Method 3 . . . . .	40
Single design in Jacquard . . . . .	40-41
● Norwegian Jacquard . . . . .	41-42
● Weaving effect . . . . .	43-44
● Patterns with needles in holding position . . . . .	44
● Garter and Lace stitches . . . . .	45
XIII WHAT TO DO IF . . . . .	46-49

# I. THE SELECTION BOX

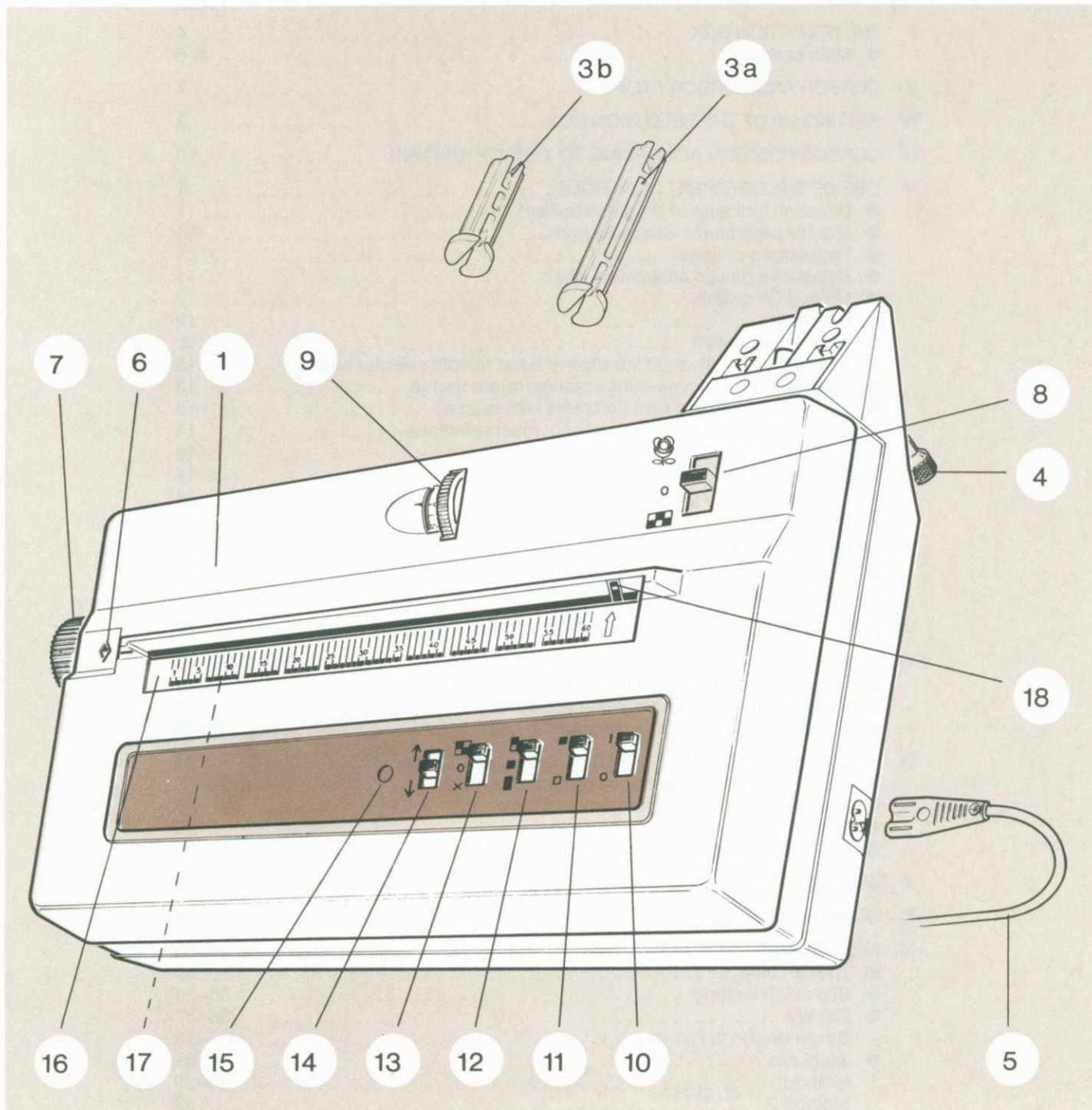

1 The Selection box

2a Geometric programme-card (see page 6)

2b Decorative programme-card (see page 6)

**3a Double bed drive shaft**

3b Single bed drive shaft

4 Mounting screws

5 Selection box power lead

6 Direction indicator of programme-card

7 Manual programme-card advance

8 Programme changer

9 Decorative design adjustment dial

10 On and Off switch

11 Reverser

12 Row repeat switch

13 Automatic row advance stop/every other needle selector switch

14 Automatic programme-card advance/return switch

15 Card-return warning light (interacts with buzzer)

16 Programme-card insertion and alignment reference

17 Pattern scanners

18 Pattern line indicator

19 Programme-card guide (see page 6)

20 Programme-card cover (see page 6)

21 Special pen for decorative design

6 Direction indicator of programme-card

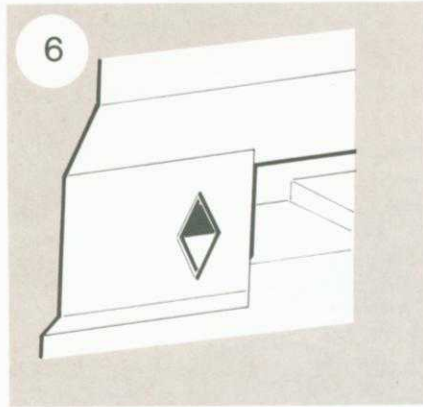

7 Manual programme-card advance

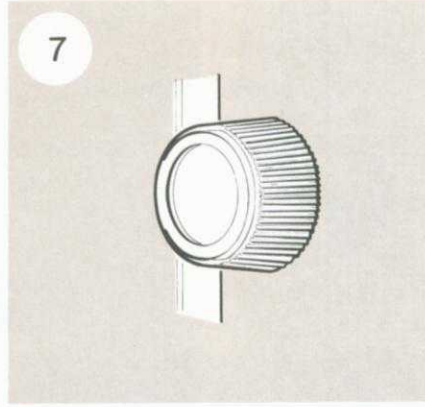

9 Decorative design adjustment dial

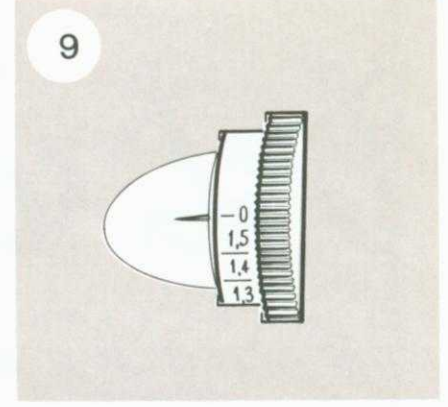

8 Programme-changer

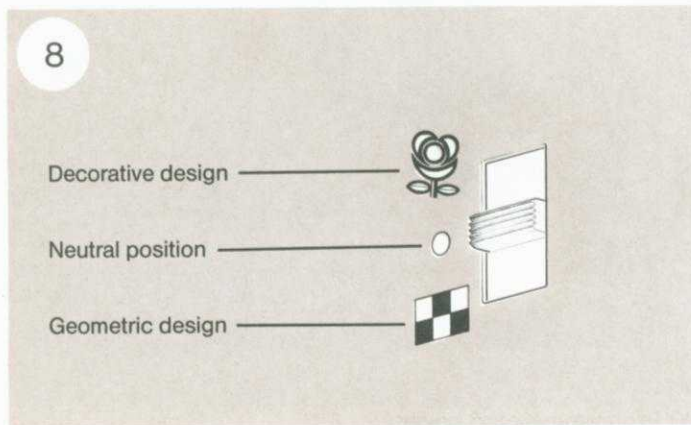

10 On and Off switch

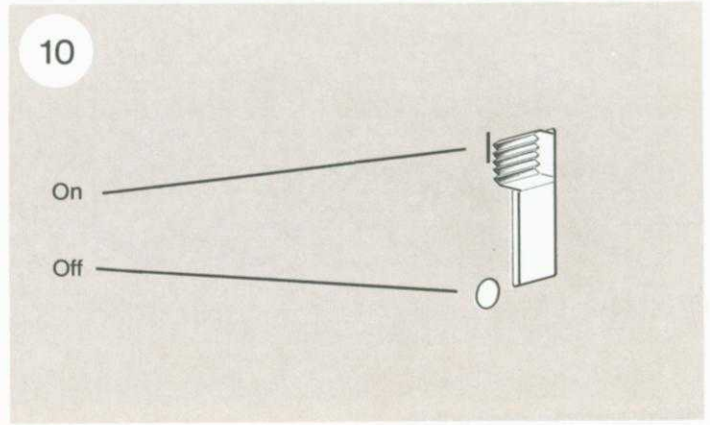

11 Reverser

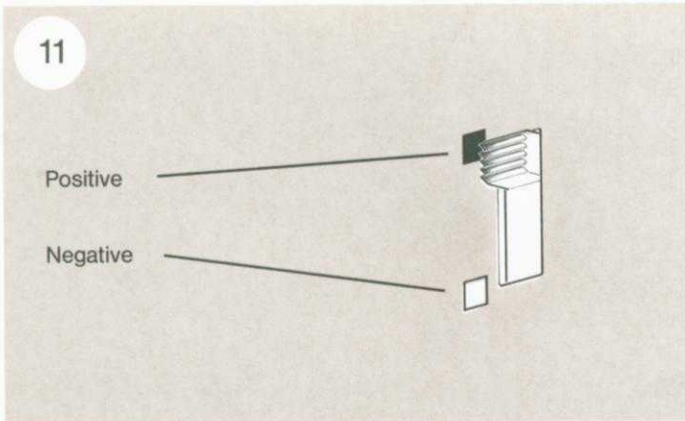

12 Row repeat switch

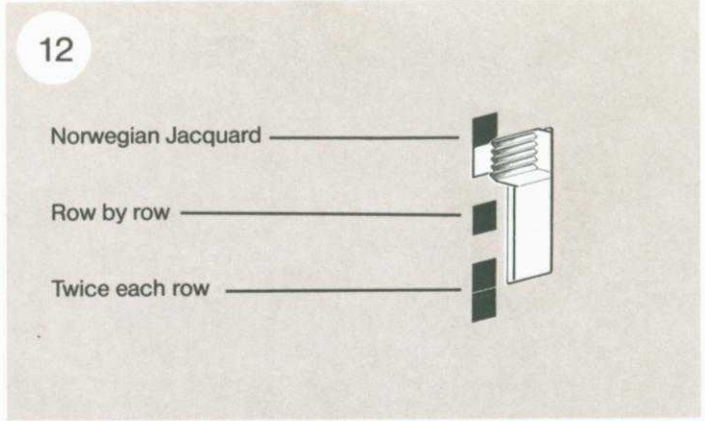

13 Automatic row advance stop/every other needle selection switch

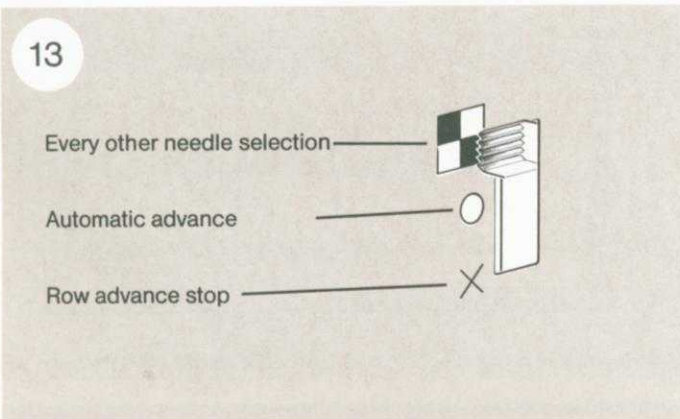

14 Automatic programme-card advance/return switch

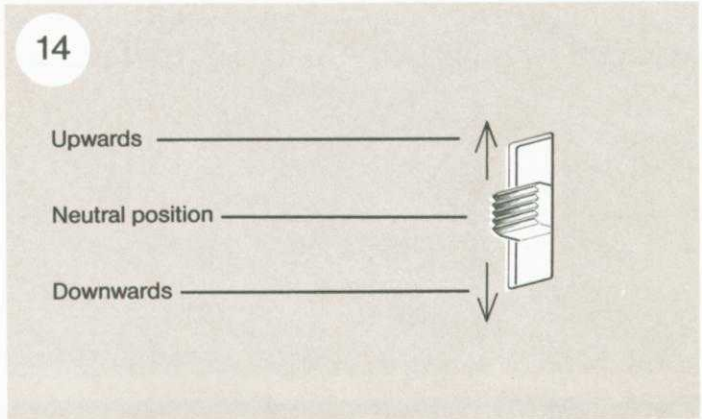

2a Geometric programme-card

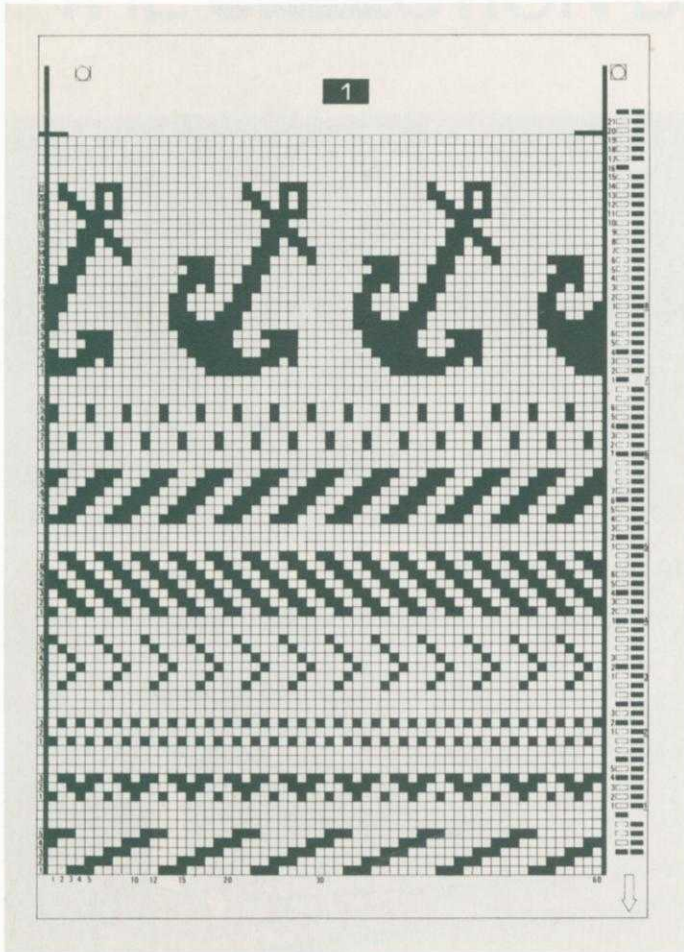

2b Decorative programme-card

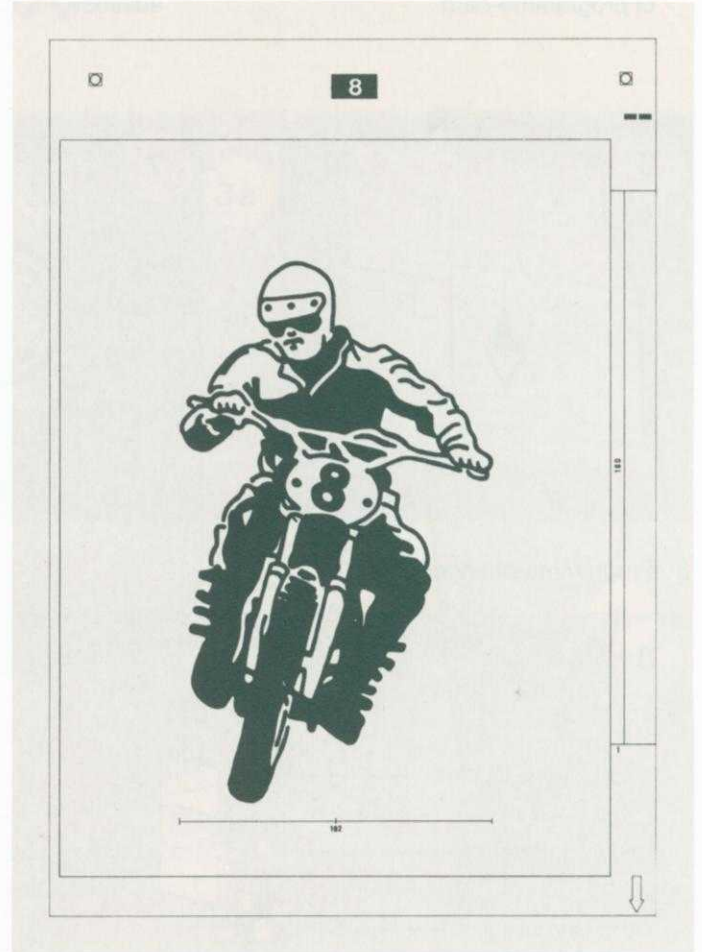

19 Programme-card guide

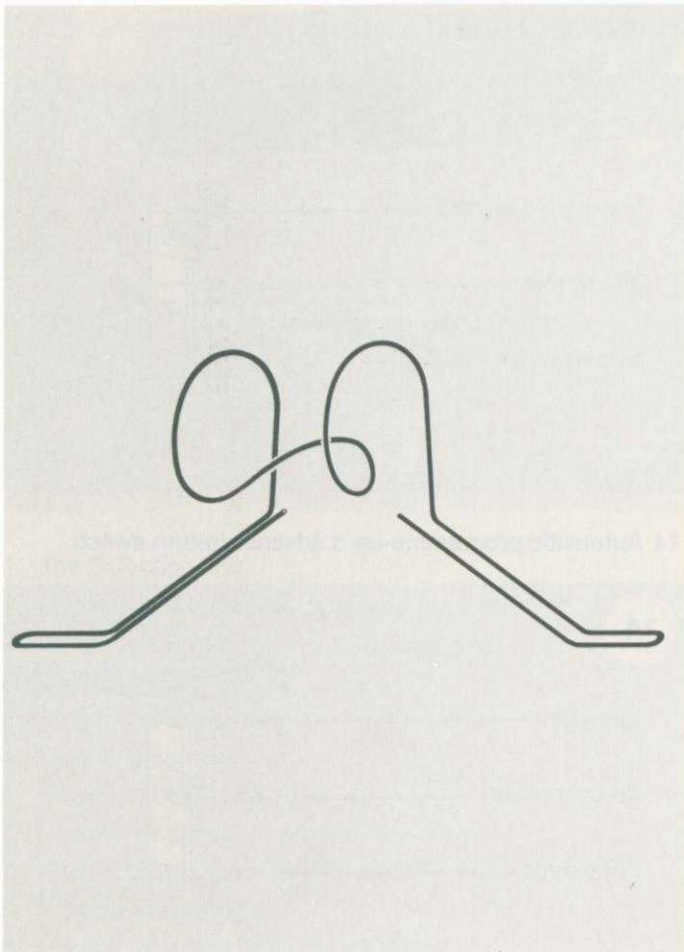

20 Programme-card cover

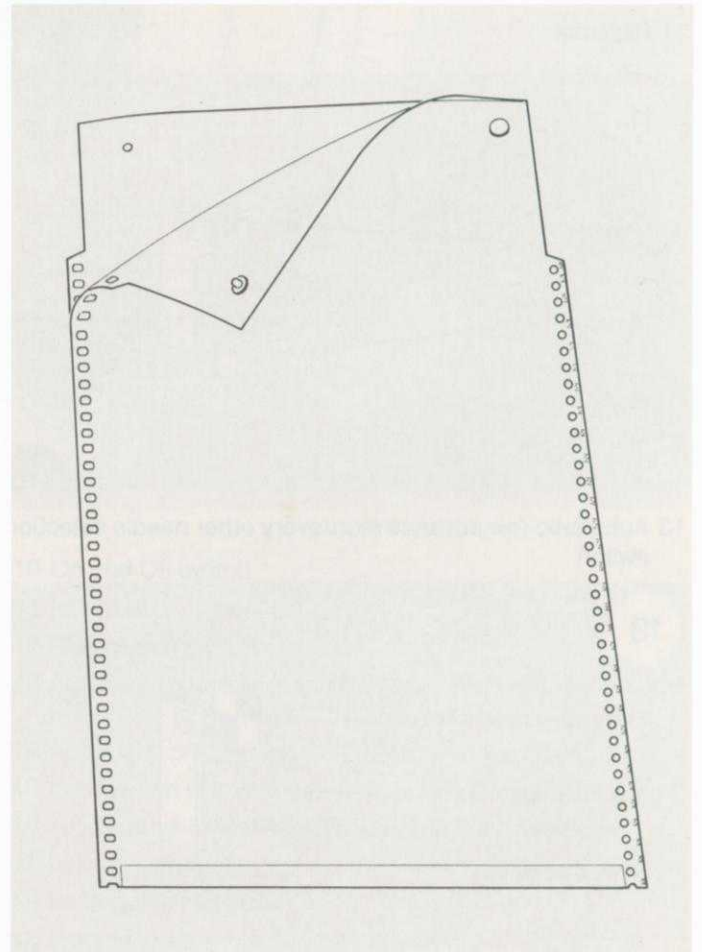

# II. CURSOR AND CURSOR STOPS

## THE CURSOR (22)

This is the connection between the Selection box and each selector block foot (23) and (24) on the back carriage.

When the carriage is moved from right to left, the cursor is carried by the left selector block foot (23).

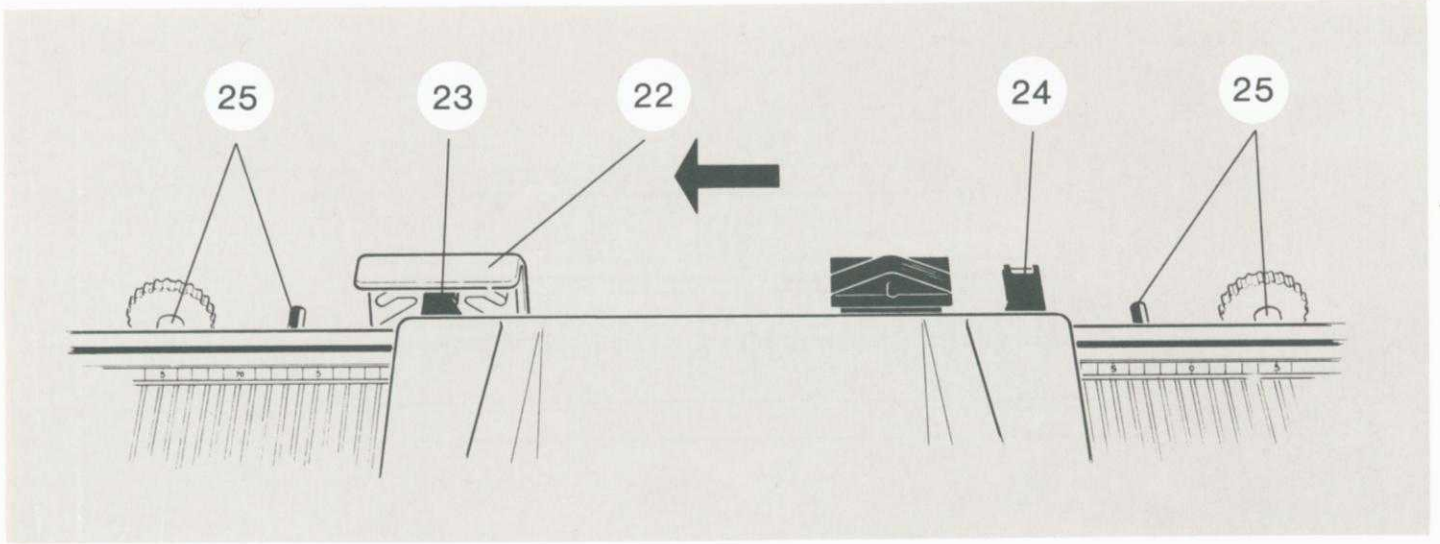

When the carriage is moved from left to right, the cursor is carried by the right selector block foot (24).

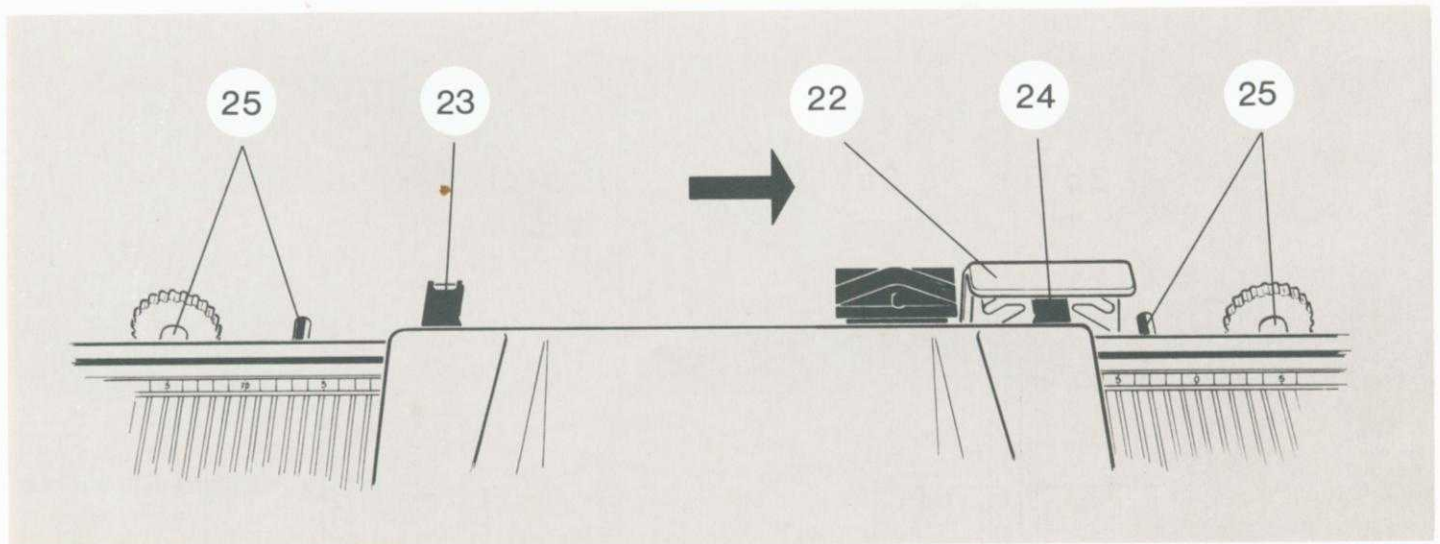

## THE CURSOR STOPS (25)

These stops enable you to control the width of the design.

After each row, make sure that the carriage has passed beyond the cursor stop (25).

To loosen, turn clockwise (to the right). To tighten, turn counter-clockwise (to the left).

# III. SETTING UP OF THE SELECTION BOX

Before attaching the selection box at the right side of the machine:

- Place the centre of the cursor exactly opposite to the 0 of the graduation of the needles. To do this, eventually untighten one of both cursor stops.

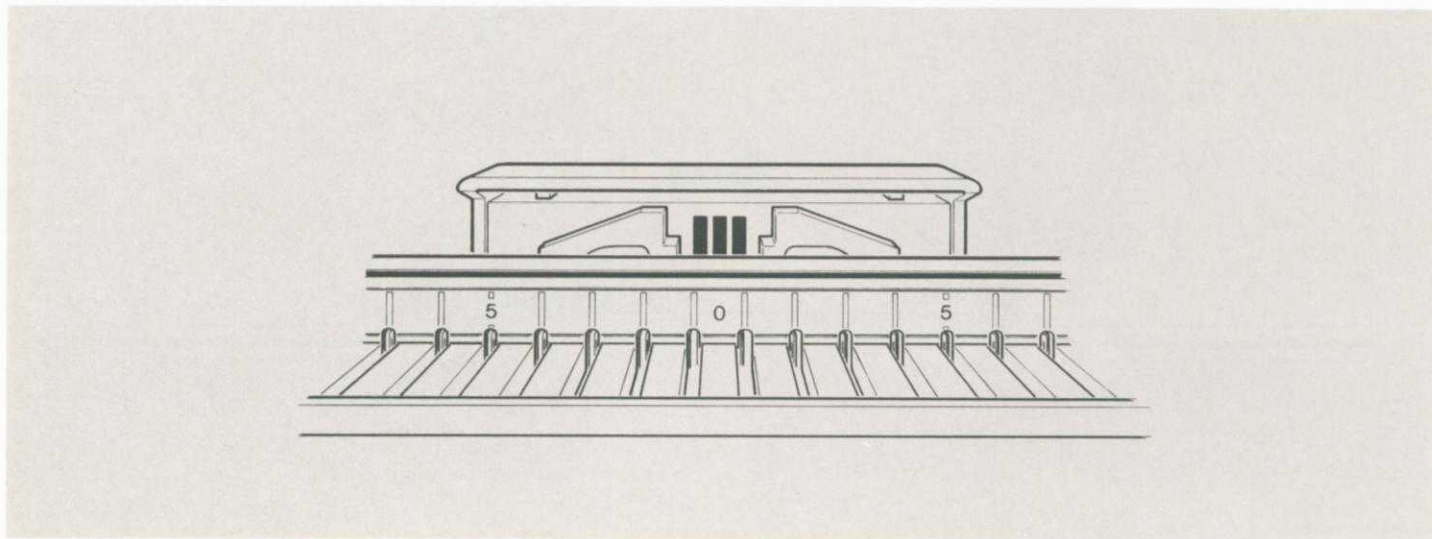

- Insert the drive shaft (3) with the collar towards selection box. If you have a single bed knitting machine, insert the shorter drive shaft (3b) supplied with your selection box. If you have a double bed knitting machine, insert the longer drive shaft (3a). Turn shaft until the slot is in horizontal position.

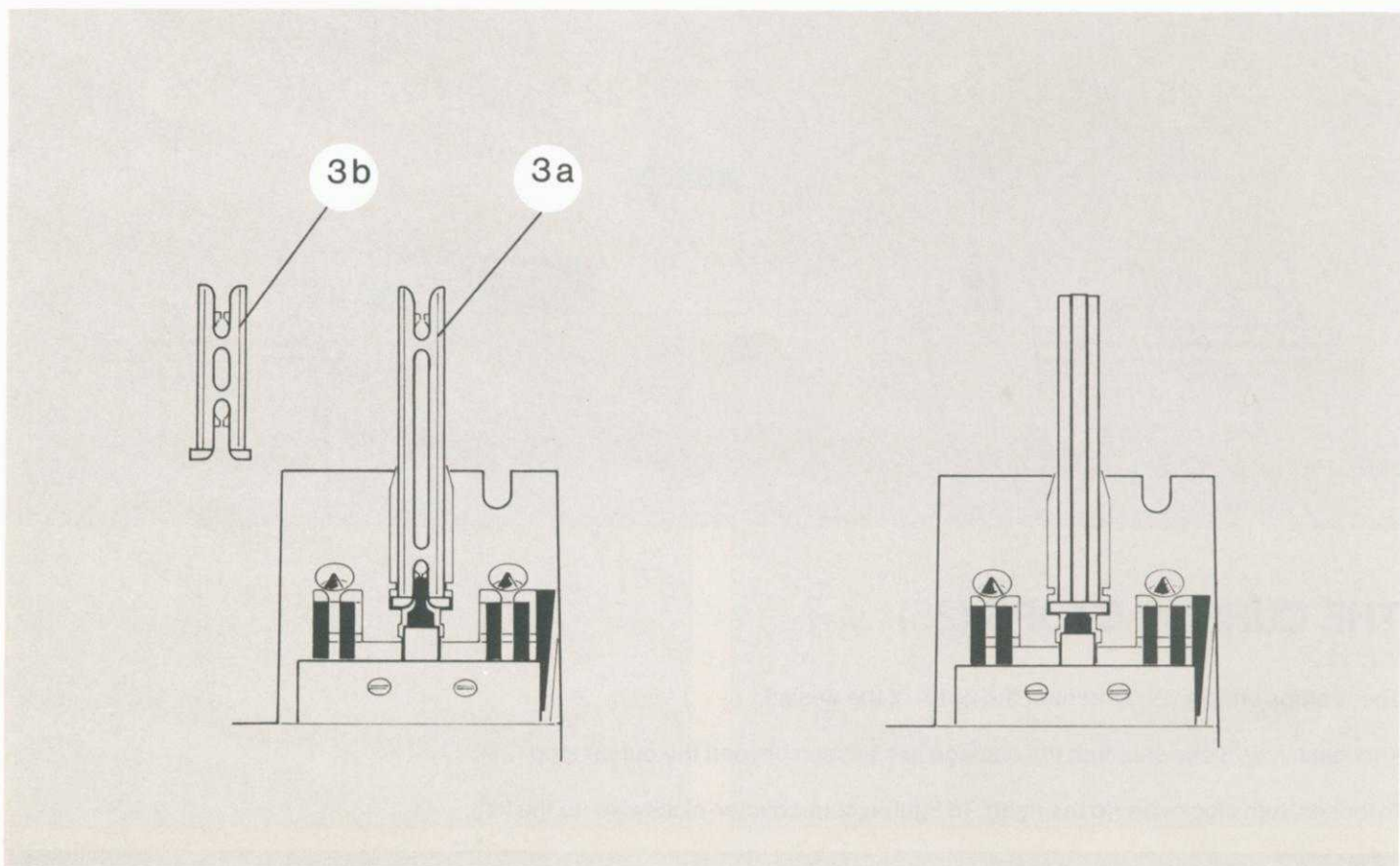



- Insert the drive shaft into the opening under the right-hand underside of the knitting machine.

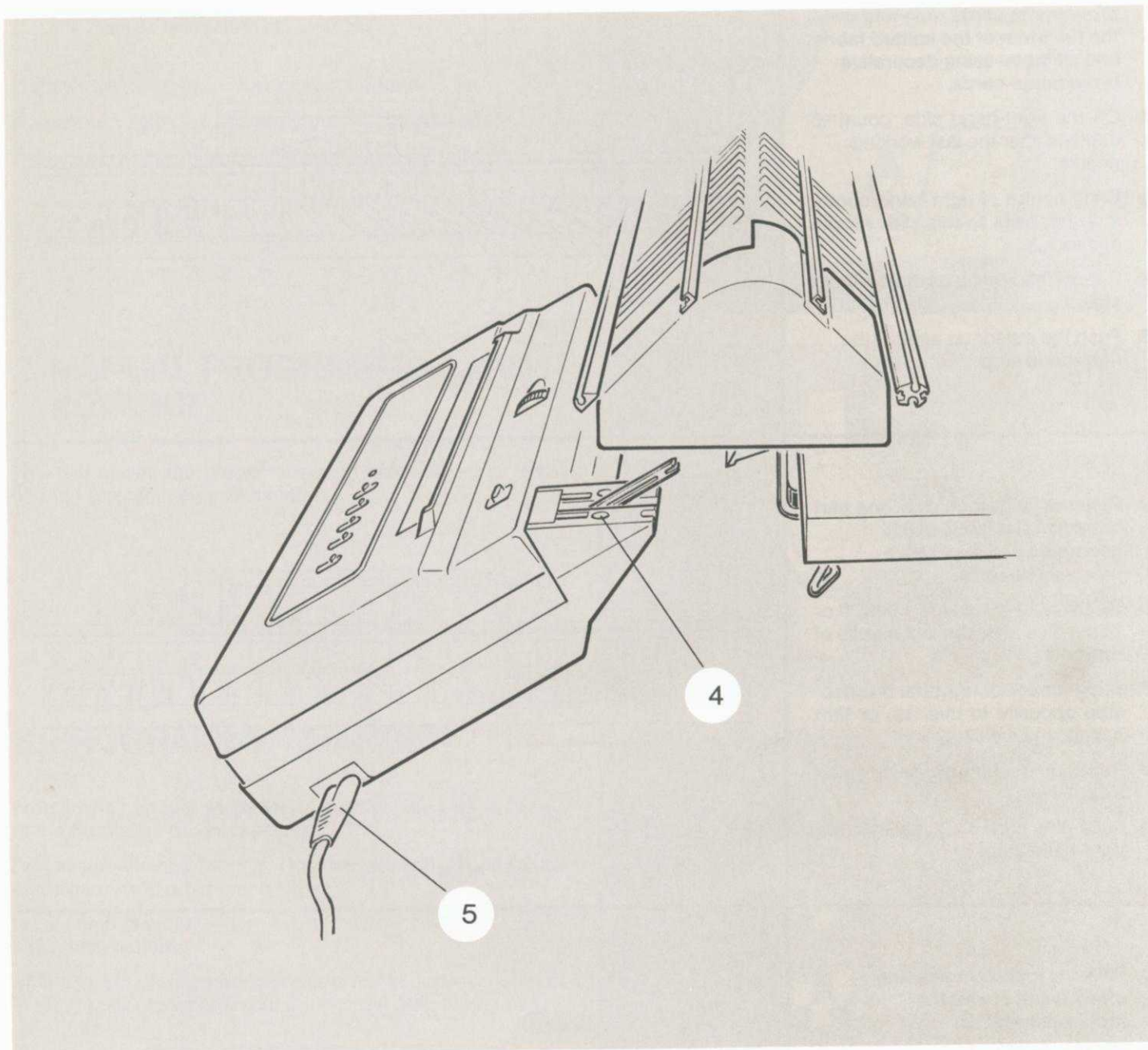

- Tighten the mounting screws (4).
- Plug the power lead (5) into the side of the selection box.
- Plug the power lead into the electrical outlet.

**CAUTION:**

Always disconnect electrical power supply when machine is not in use.

# IV. CURSOR POSITION ACCORDING TO TYPE OF KNITTING

## A. All patterns, except weaving effect, using geometric programme-cards repeated over the full width of the knitted fabric and all those using decorative programme-cards.

- On the right-hand side, count 15 needles after the last working needle.
- Bring centre of right-hand cursor stop opposite to this 15th needle and lock it.
- Repeat this setting on the left-hand side.
- Push the cursor up against the right-hand stop.

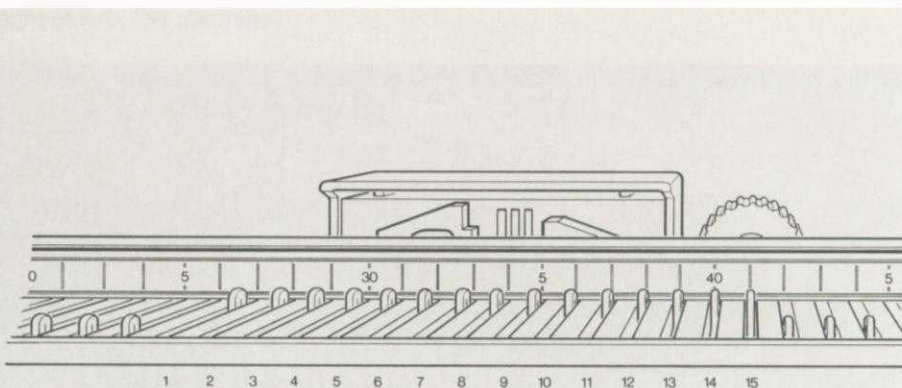

## B. Patterns knitted on only one part of the knitted fabric using geometric and decorative programme-cards.

- On the right-hand side, count 11 or 12 needles after the last needle of the motif.
- Bring centre of right-hand cursor stop opposite to this 11th or 12th needle and lock it.
- Repeat this setting on the left-hand side.
- Push the cursor up against the right-hand stop.

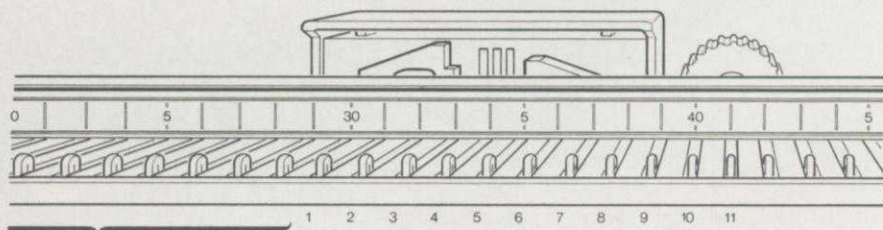

## C. Patterns knitted in weaving effect using geometric programme-cards.

- On the right-hand side, count 8 needles after the last pattern needle.
- Bring centre of right-hand cursor stop opposite to the 8th needle and lock it.
- Repeat this setting on the left-hand side.
- Push the cursor up against the right-hand stop.

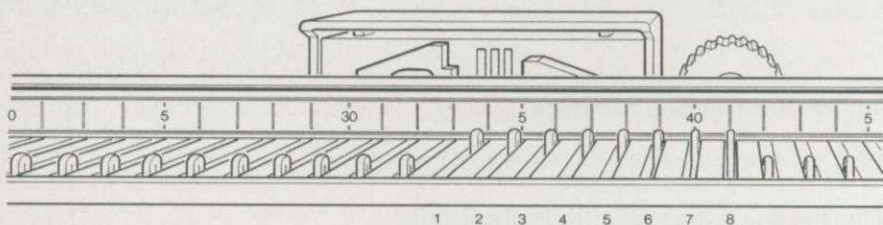

# V. USE OF THE DIFFERENT CONTROLS

## 1. DIRECTION INDICATOR OF PROGRAMME-CARD

It shows the direction of the programme-card.

Red arrow pointing up, the programme-card goes up.

Red arrow pointing down, the programme-card goes down.

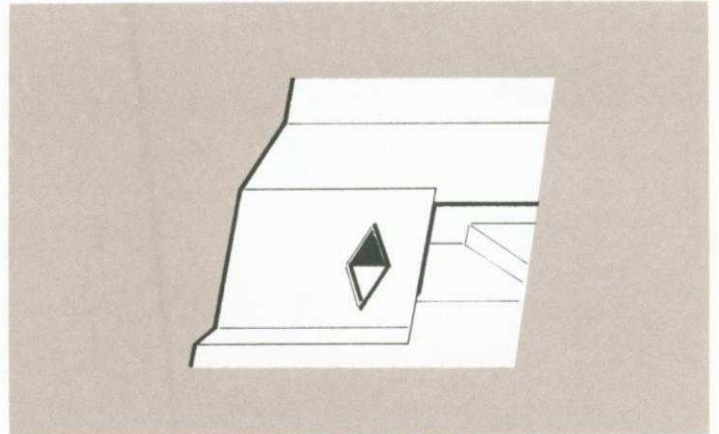

## 2. MANUAL PROGRAMME-CARD ADVANCE

This dial moves the programme-card manually up or down and for programme-card insertion.

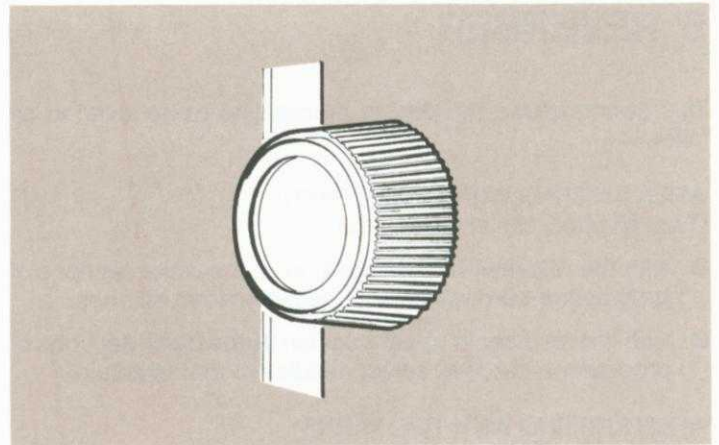

## 3. PROGRAMME-CHANGER

Programme-changer when set to upper position  is for use of the decorative programme-card.

Programme-changer when set to lower position  is for use of the geometric programme-card.

Programme-changer when set to neutral position  is for setting the pattern.

After this, set programme-changer either in upper position or in lower position according to the chosen programme-card.

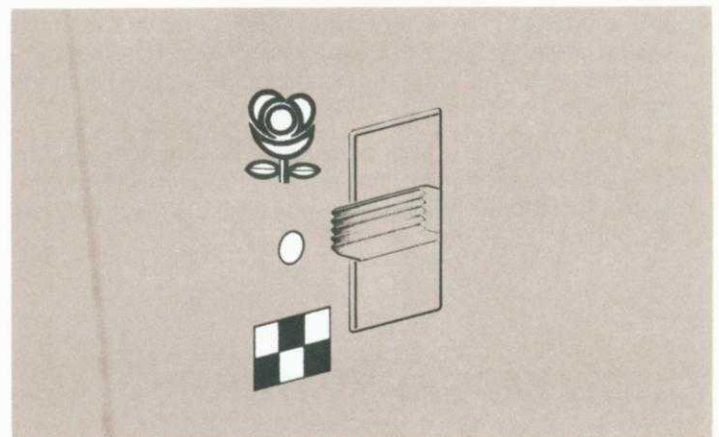

## 4. DECORATIVE DESIGN ADJUSTMENT DIAL

To insert a programme-card, place the 0 of the dial opposite to the reference mark.

a) After insertion of a geometric programme-card, place figure 1 opposite to the reference mark.

b) After insertion of a decorative programme-card, place the result of the division  $\frac{\text{number of stitches per 10 cm}}{\text{number of rows per 10 cm}}$  opposite to the reference mark.

You can find this result on chart page 28.

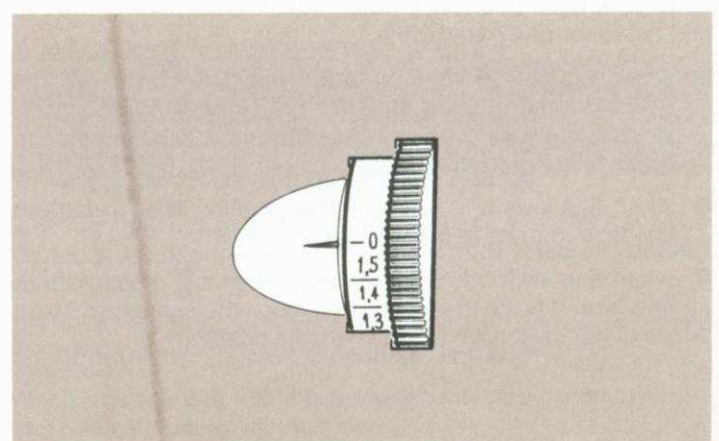

## 5. ON AND OFF SWITCH

This is the main ON-OFF switch for the selection box.

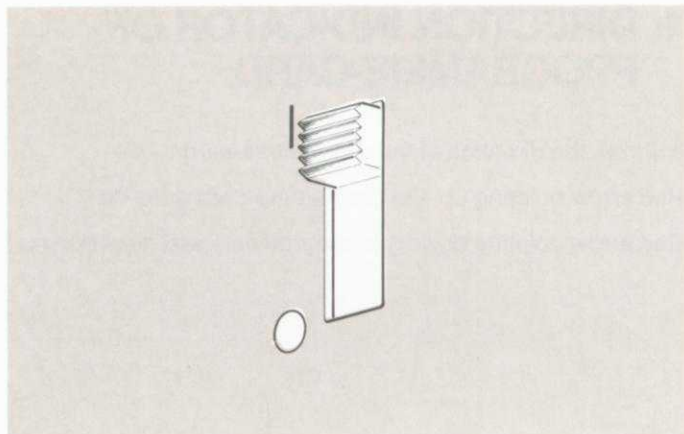

## 6. REVERSER

This switch allows the design programme to be inverted as follows: –

WHEN KNITTING WITH SINGLE YARN:  
(Tuck stitches, slip stitches, etc.)

- with the reverser in lower position □, the white sections of programme-card will select needles to form stitches.
- with the reverser in upper position ■, the black sections of programme-card will select needles to form stitches.

WHEN KNITTING WITH TWO YARNS:  
(two-colour work)

- with the reverser in lower position □, the needles selected by the white sections of the programme-card will knit the second colour yarn and the remaining needles will knit the main yarn.
- with the reverser in upper position ■, the needles selected by the black sections of the programme-card will knit the second colour yarn and the other needles will knit the main yarn.

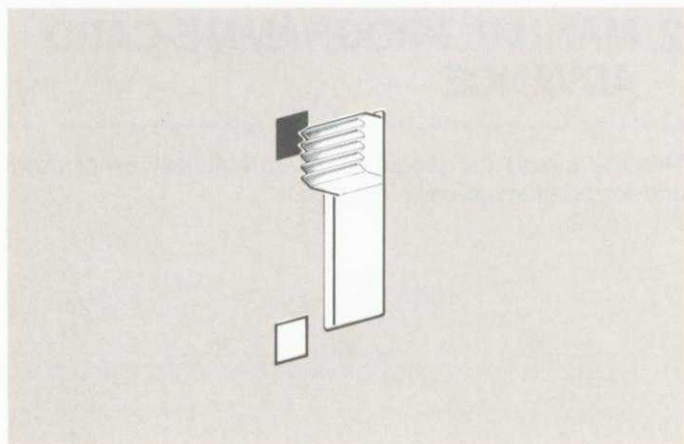

## 7. ROW REPEAT SWITCH

According to its position, it determines the number of rows to be knitted for one pattern line.

- when this switch is set in upper position ■ you will get the automatic programming of the Norwegian Jacquard, i.e., a same line of the programme-card is read twice in order to knit one row.
- when this switch is set in middle position ■ each pattern line is read once in order to knit one row.
- when this switch is set in lower position ■ each pattern line is read twice in order to knit twice the same row. Make sure that switch (8) is set in middle position ○.

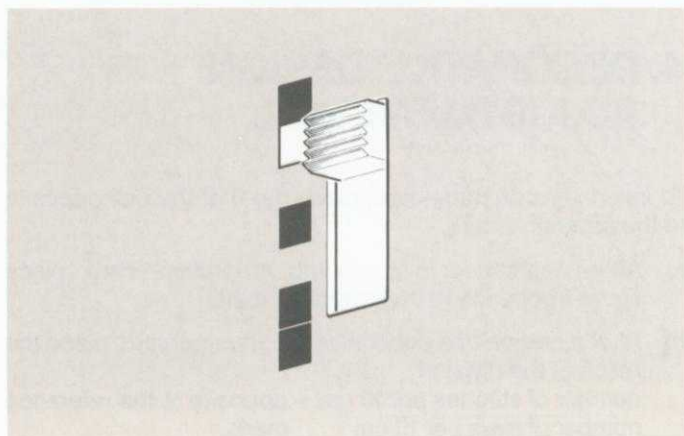

## 8. AUTOMATIC ROW ADVANCE STOP/EVERY OTHER NEEDLE SELECTOR SWITCH

### MIDDLE POSITION:

When switch is in middle position  $\bigcirc$  the programme-card advances normally.

### UPPER POSITION WITHOUT PROGRAMME-CARD:

When this switch is set in upper position  $\blacksquare$  every other needle on the back bed will automatically be selected. This needle selection is automatically reversed on the next row.

Example: with two yarns: bird's eye  
with one yarn: honey comb

### UPPER POSITION WITH PROGRAMME-CARD:

When this switch is set in upper position  $\blacksquare$  you will get automatic selection of every other needle on the back bed in the area corresponding to the white sections of the programme-card.

### LOWER POSITION (Row advance stop):

When this switch is set in lower position  $\times$  the automatic advance of the programme-card is stopped, and the same pattern row will be continuously repeated.

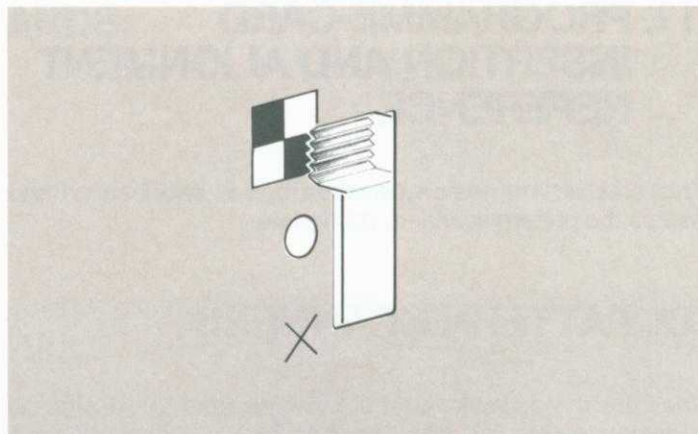

## 9. AUTOMATIC PROGRAMME-CARD ADVANCE/RETURN SWITCH

When this switch is held in upper position  $\uparrow$  the programme-card advances row by row, upwards.

When this switch is held in lower position  $\downarrow$  the programme-card advances row by row, downwards.

When switch is given a short impulse upwards,  $\uparrow$  the programme-card is advanced one row only up.

When switch is given a short impulse downwards,  $\downarrow$  the programme-card is advanced one row only down.

NOTE: it is always the last impulse which determines the direction of programme-card travel.

## 10. CARD-RETURN WARNING LIGHT (INTERACTS WITH BUZZER)

### 1. CARD INSERTION

Warning light/buzzer signals that card is set to knit first row of design or motif.

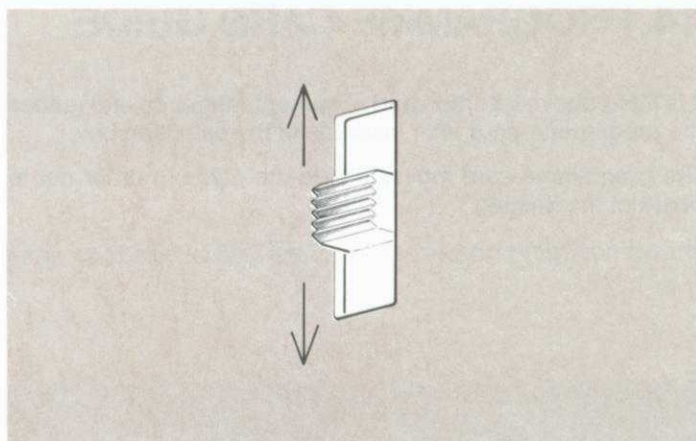

### 2. WHEN KNITTING SYMMETRIC DESIGN

Warning light/buzzer signals last row to be knitted before reversing direction of travel.

### 3. WHEN KNITTING UNSYMMETRIC DESIGN

Warning light/buzzer signals that card is now on last row to be knitted after which, programme-card returns rapidly to starting point. Knitting can now be resumed.

NOTE: When the row repeat switch is set in lower or upper position, knit two rows after hearing the buzzer.

When you resume knitting the direction of programme-card has been automatically reversed.

## 11. PROGRAMME-CARD INSERTION AND ALIGNMENT REFERENCE

This area is lit up when selection box is switched on and makes the pattern scanners (12) visible.

## 12. PATTERN SCANNERS

They are three pattern-scanners which read the design on programme-card, but only one scanner is visible at one time. A white reference mark on scanners is used when positioning a design.

## 13. PATTERN LINE INDICATOR

This indicator is visible through a round perforation of the programme-card cover.

It is used to align the programme-card.

## 14. PROGRAMME-CARD GUIDE

It is fitted above insertion and alignment reference and guides the programme-card after insertion in the selection box.

The programme-card moves inside the guide in order not to obstruct the knitting.

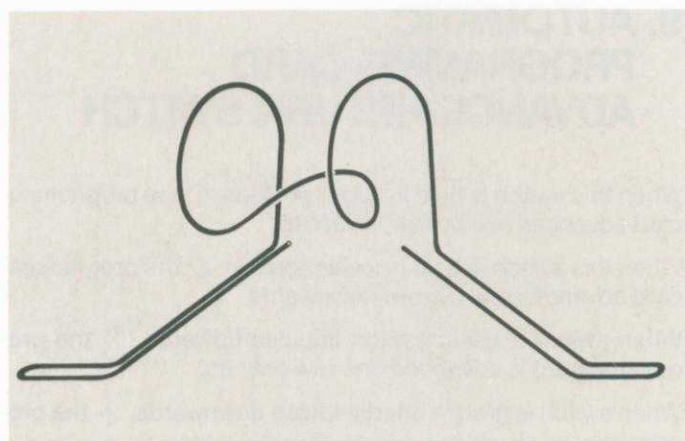
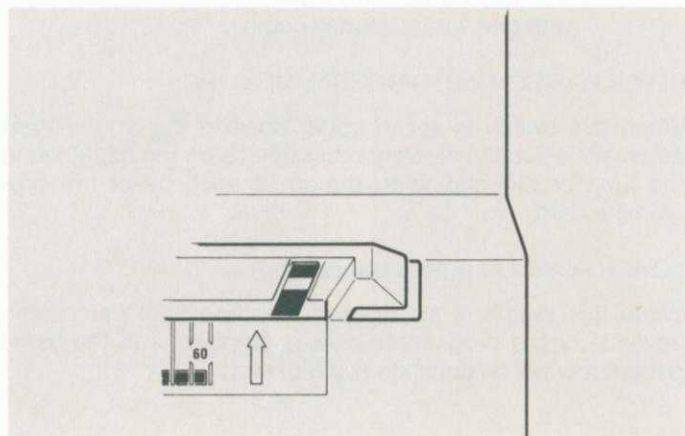
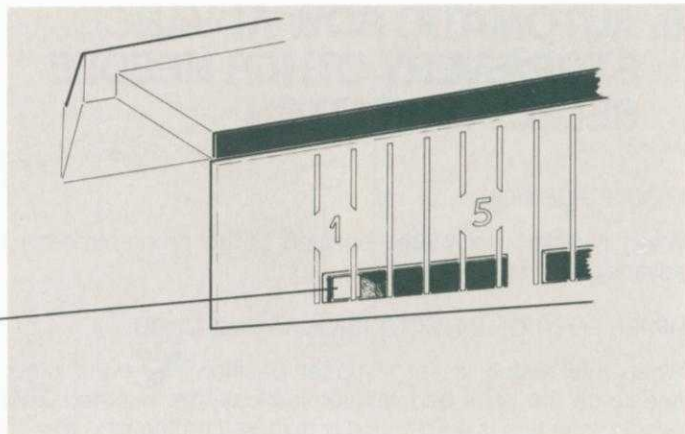

# VI. SETTING OF A MOTIF



All patterns can be set at the place of your choice.

## USING GEOMETRIC PROGRAMME-CARDS:

a) To centralise a design on your fabric:

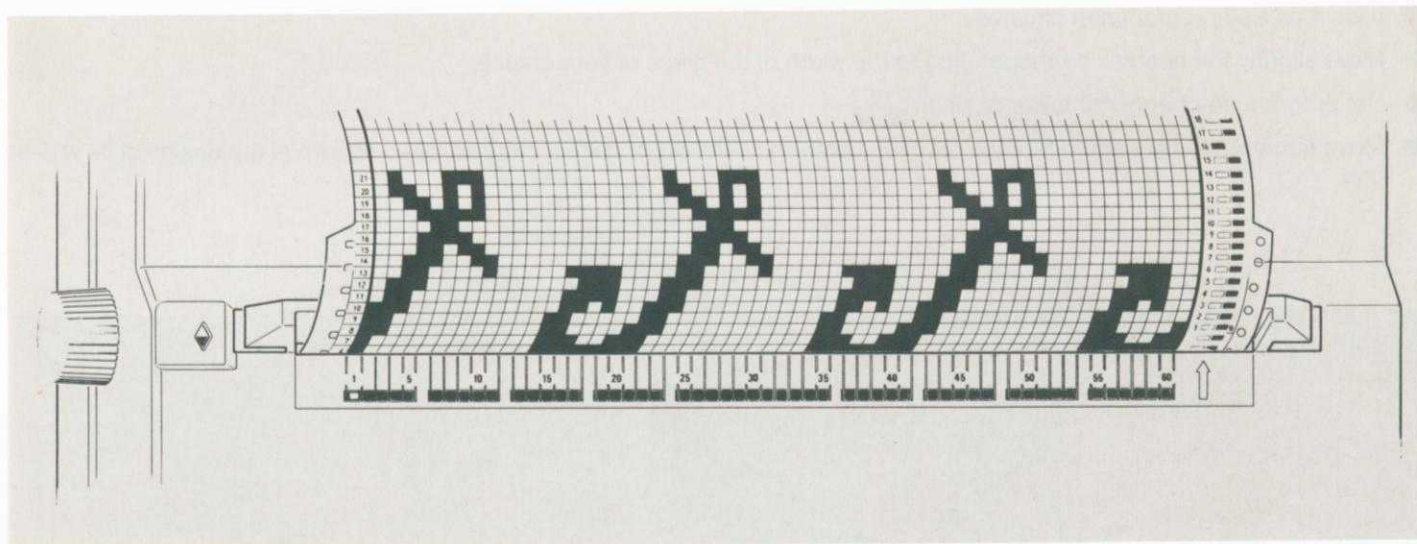
- Set programme-changer to lower position .
- Move cursor to bring white reference mark of a pattern scanner opposite to first left-hand square on programme-card insertion and alignment reference.



- Set programme-changer to neutral position .
- Bring centre of cursor opposite to first needle left of 0 on the graduated scale.
- Set programme-changer to lower position .
- Bring cursor to same side as carriage.

b) To set a design at the place of your choice:

- Set programme-changer to lower position .
- Move cursor to bring white reference mark of a pattern scanner opposite to first left-hand square on programme-card insertion and alignment reference.

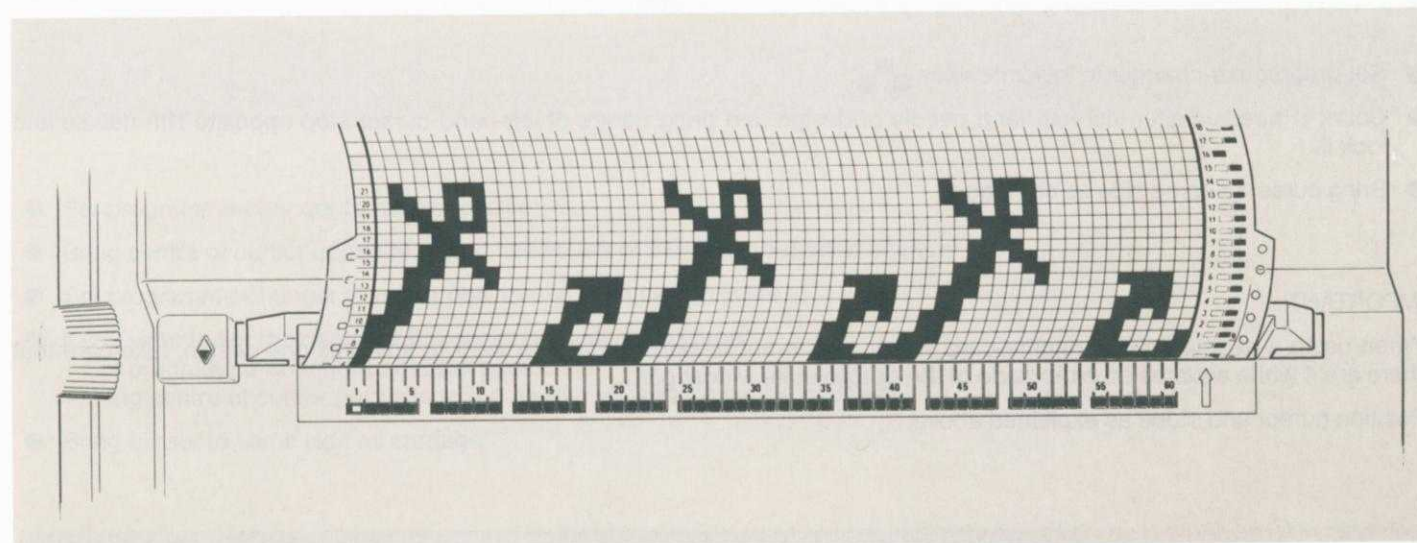

- Set programme-changer to neutral position ○.
- Bring centre of cursor opposite to the chosen needle which is centre of the design.
- Set programme-changer to lower position .
- Bring cursor to same side as carriage.

c) To set a single design in two-colour work at the place of your choice:

- Use a geometric programme-card showing the design of your choice, taking care that the design does not exceed at its widest part 56 programmed squares.
- Move slightly the needles corresponding to the width of the place of your choice.
- Set programme-changer to lower position .
- Move cursor to bring white reference mark of a pattern scanner opposite to first left-hand square of the design at its widest part.

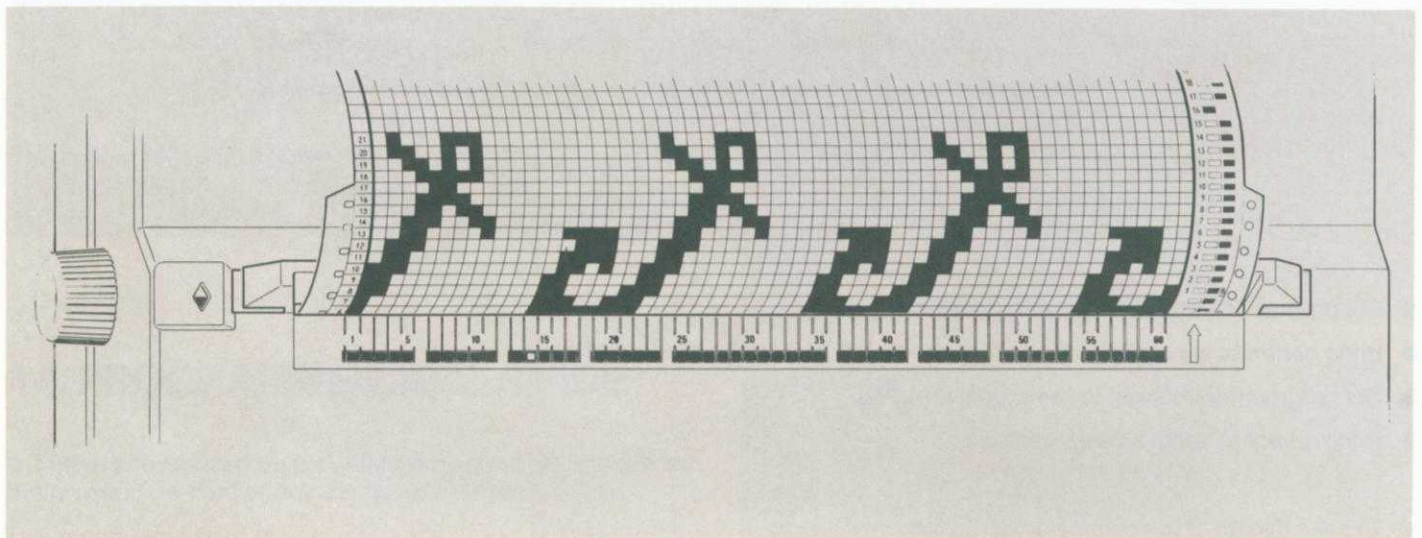

- Set programme-changer to neutral position ○.
- Bring centre of cursor opposite to first right-hand needle of the needle group selected for the design.
- Count 11 needles after last right-hand needle of design and bring centre of right-hand cursor stop opposite 11th needle and lock it.
- Set programme-changer to lower position .
- Count 11 needles after last left-hand needle of design and bring centre of left-hand cursor stop opposite 11th needle and lock it.
- Bring cursor to same side as carriage.

#### IMPORTANT:

When using a geometric programme-card showing different designs and if you want to knit only one design, take care that there are 4 white squares on either side of the design at its widest part.



Position cursor and stops as explained above.

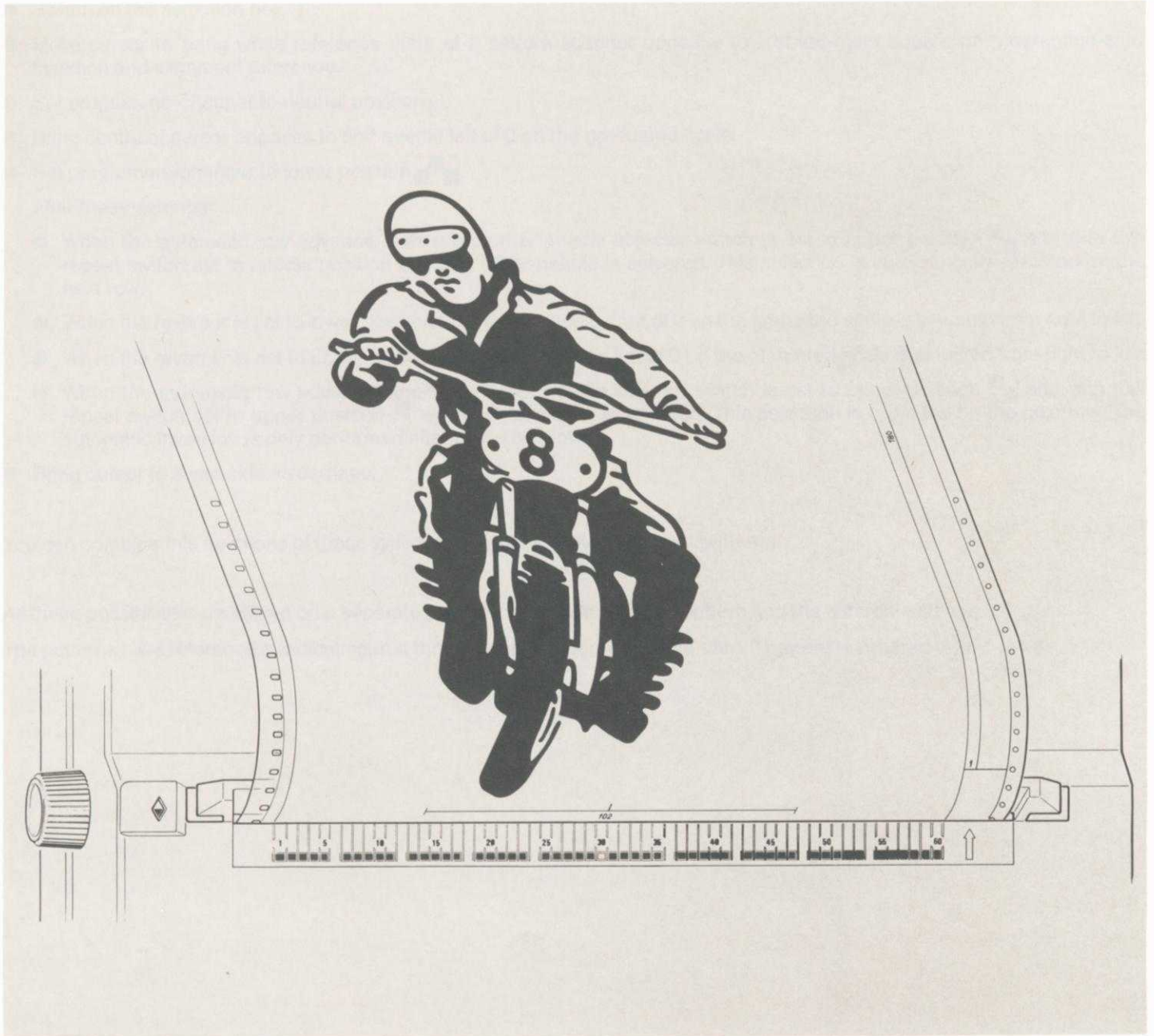

## USING DECORATIVE PROGRAMME-CARD

- Set programme-changer to lower position .
- Move cursor to bring white reference mark of a pattern scanner opposite to central reference mark on programme-card.







- Set programme-changer to neutral position .
- Bring centre of cursor opposite to first needle left of 0 on the graduated scale.
- Set programme-changer to upper position : the design is set.
- If you want to set the centre of the design at a different place:
  - Set programme-changer to neutral position .
  - Bring centre of cursor opposite to the needle chosen for centre of design.
- Bring cursor to same side as carriage.







**NOTES:**

---

# VII. HOW TO USE THE SELECTION BOX WITHOUT PROGRAMME-CARD

- Carriage to the right-hand side.
- Row counter – 000.
- Set programme-changer in lower position .
- Switch on the selection box .
- Move cursor to bring white reference mark of a pattern scanner opposite to first left-hand square on programme-card insertion and alignment reference.
- Set programme-changer to neutral position .
- Bring centre of cursor opposite to first needle left of 0 on the graduated scale.
- Set programme-changer to lower position .

After these settings:

- When the automatic row advance stop/every other needle selector switch is set to upper position  and with row repeat switch set to middle position , every other needle is selected. This selection is automatically reversed on the next row.
- When the reverser is set to lower position : the first needle right of 0 on the graduated scale is selected from right to left.
- When the reverser is set to upper position : the first needle left of 0 on the graduated scale is selected from right to left.
- When the automatic row advance stop/every other needle selector switch is set to upper position  and with row repeat switch set to upper position  every other needle is selected. This selection is repeated on the next row. The automatic inversion is only performed after these two rows.
- Bring cursor to same side as carriage.

You can combine this functions of these switches in order to obtain different patterns.

All these possibilities are shown on a separate pattern chart illustrating the pattern and the different settings.

The patterns have reference A indicating that they do not need a programme-card. They are numbered from 1 to 18.

# VIII. HOW TO USE THE SELECTION BOX WITH GEOMETRIC PROGRAMME-CARD

## A. DESCRIPTION OF THE GEOMETRIC PROGRAMME-CARD

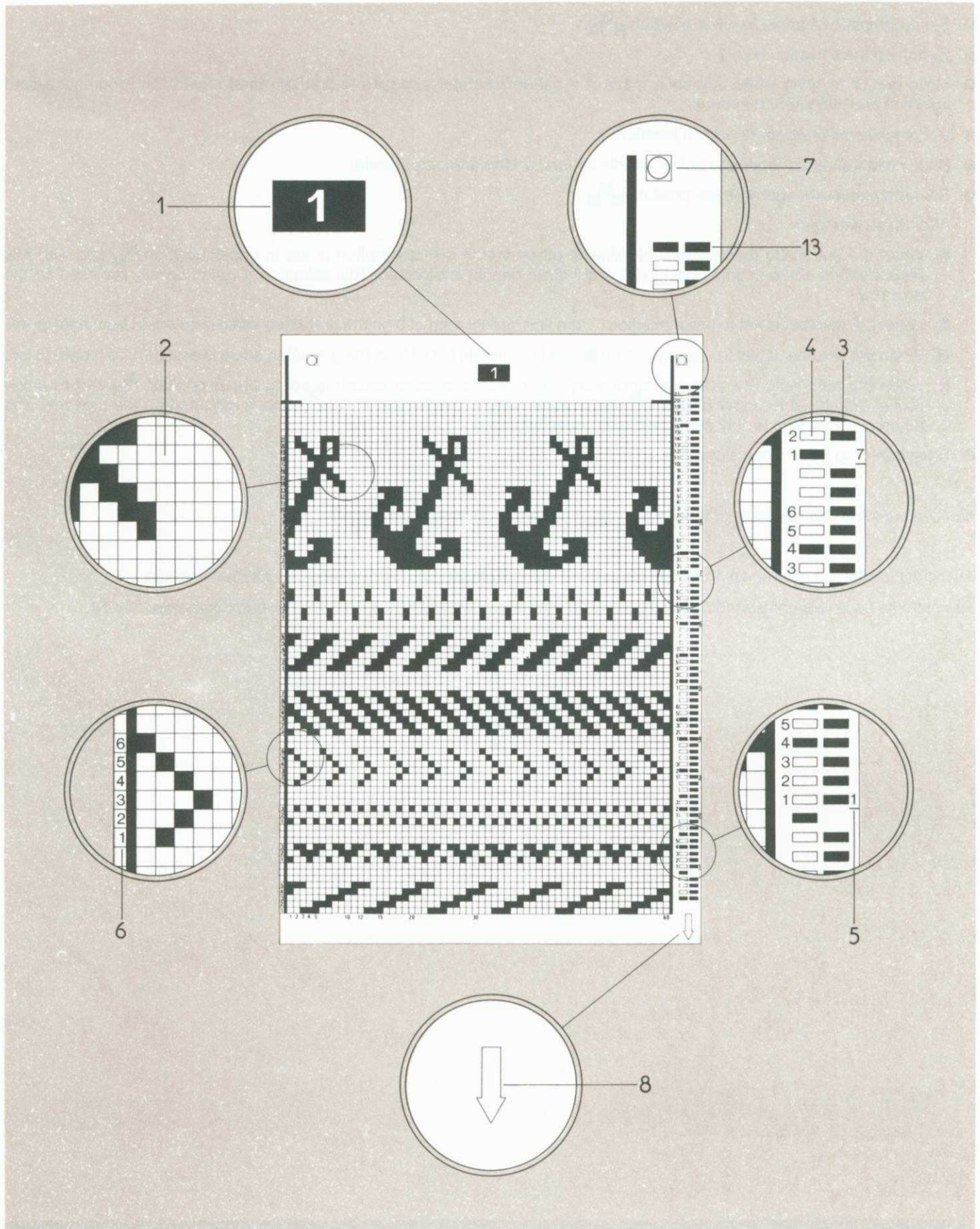

The card reference number is printed on top and in the middle of the card (mark 1). The card has a geometrically squared area (2) bordered by two heavy vertical lines. Motifs up to 60 stitches are drawn within this area.

A 3 mm square corresponds to 1 needle, therefore 1 stitch.

To the right of this area are two columns. In the column (3) are black squares which command advance or return travel of programme-card row by row when knitting symmetrical patterns. The inversion of the travel is accompanied by warning light/buzzer signal.

In the column (4) are black squares which command the rapid return of programme-card to the starting point of the pattern. This movement is accompanied by warning light/buzzer signal.

When there are two black squares opposite in column (3) and (4), the card travel is inverted and pattern selection is made row by row.

Two black squares are always located on top of column (3) and (4). If you have forgotten to switch off the selection box after the end of a pattern, these squares will limit the programme-card travel and reverse it. It is accompanied by the warning light/buzzer signal.

To the right of the squared area are numbers which correspond to the number of row which is presently knitted. This number is then opposite to the pattern line indicator on the selection box.

A reference line (5) indicates beginning of each motif when it is opposite to the pattern line indicator on the selection box.

#### NOTE:

The reference line of starting point of design is located 7 lines above this point. This reference line must be opposite to the pattern line indicator on the selection box, visible through the cover, as illustrated page 23.

To the left of the programme-card is numbering (6) of each line of motif. On the upper part of the card are also two holes (7) which allow to position the card onto the studs (11) of the programme-card cover.

An arrow (8) is printed on the bottom of the card. It shows which way you have to insert the programme-card in the selection box.

The number of the motif is indicated to the right of both columns (3) and (4), above reference line of starting point.

We inform you that heavy lines on the upper part of the card only have a technical function.

## B. DESCRIPTION OF THE PROGRAMME-CARD COVER

The purpose of this cover is to hold the programme-card. It is composed of two transparent plastic sheets sealed on the right-hand side. One plastic sheet is thinner than the other one.

The cover is also sealed at the bottom to get a better insertion into the selection box.

The cover has two vertical rows of perforations – oval ones (9) on the left-hand side, round ones (10) on the right-hand side –, which are for the programme-card cover drive.

This cover also has two positioning studs (11) located near the top of the upper sheet as well as two perforations (7) on the thinner sheet. These studs are used to position and maintain the card inside the cover.

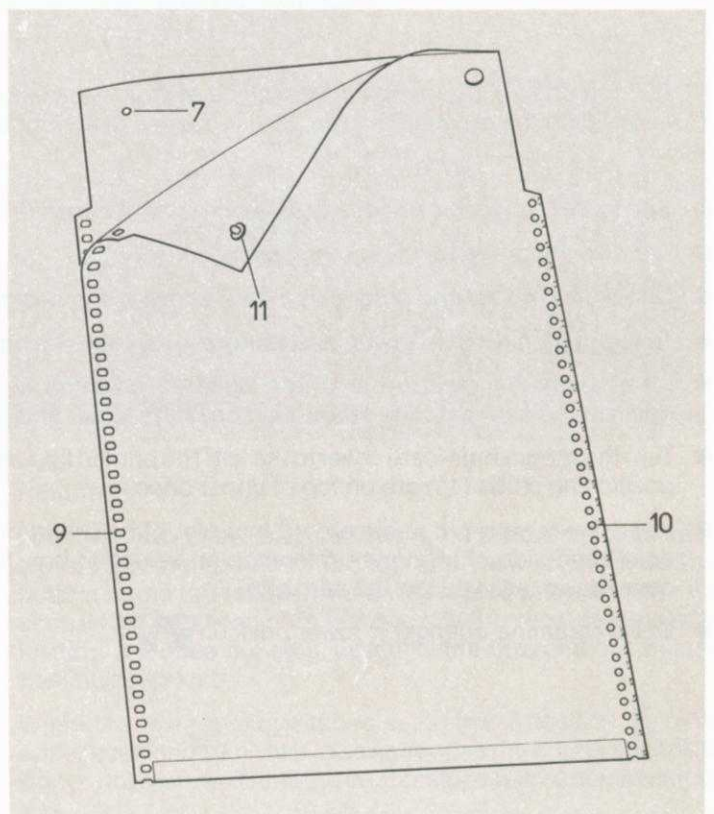

## C. USE OF THE GEOMETRIC PROGRAMME-CARD

The following settings must be made when starting knitting of pattern.

- Switch on the selection box: this will light up.
- Set programme-changer in lower position .
- Move cursor to bring white reference mark of a pattern-scanner opposite to first left-hand square on programme-card insertion and alignment reference.

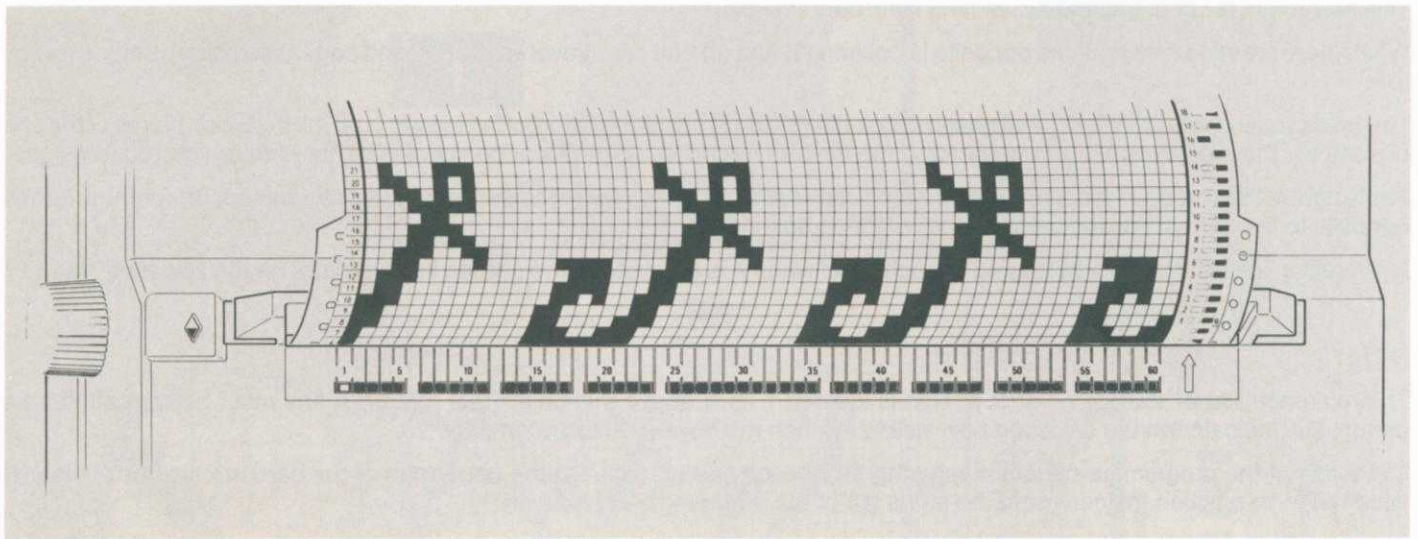

- Set programme-changer to neutral position .
- Bring centre of cursor opposite to first needle left of 0 on the graduated scale.

NOTE: You can set the pattern at the place of your choice but instead of setting the centre of cursor opposite to first needle left of 0 on the graduated scale, set it opposite to the chosen needle which must knit the first left-hand square.

- Set figure 0 of decorative design adjustment dial opposite to the reference mark.
- Remove the programme-card guide if necessary.
- Choose the geometric programme-card showing the design of your choice.
- Take programme-card cover, oval perforations (9) to the right-hand side and positioning studs (11) on top of lower sheet.
- Insert programme-card into cover, squared columns (3) and (4) to the left-hand side, arrow (8) pointing down and position the card onto the studs. Fold back the sheet and press it onto the studs to hold the card.
- Turn the programme-card cover to the left. The printed figures can be read, the oval perforations (9) are on left-hand side and the positioning studs (11) are on top of upper sheet.
- Insert cover with programme-card into slot of selection box making arrow (8) on card correspond with arrow located on right-hand side of alignment reference on selection box. Make sure that it is inserted straight and push programme-card cover down until you feel the card grip.
- Set programme-changer in lower position .

- Bring cursor to same side as carriage.
- To position card, turn manual card advance dial towards you until positioning studs of cover are level with top of selection box.
- Fit programme-card guide, as illustrated.

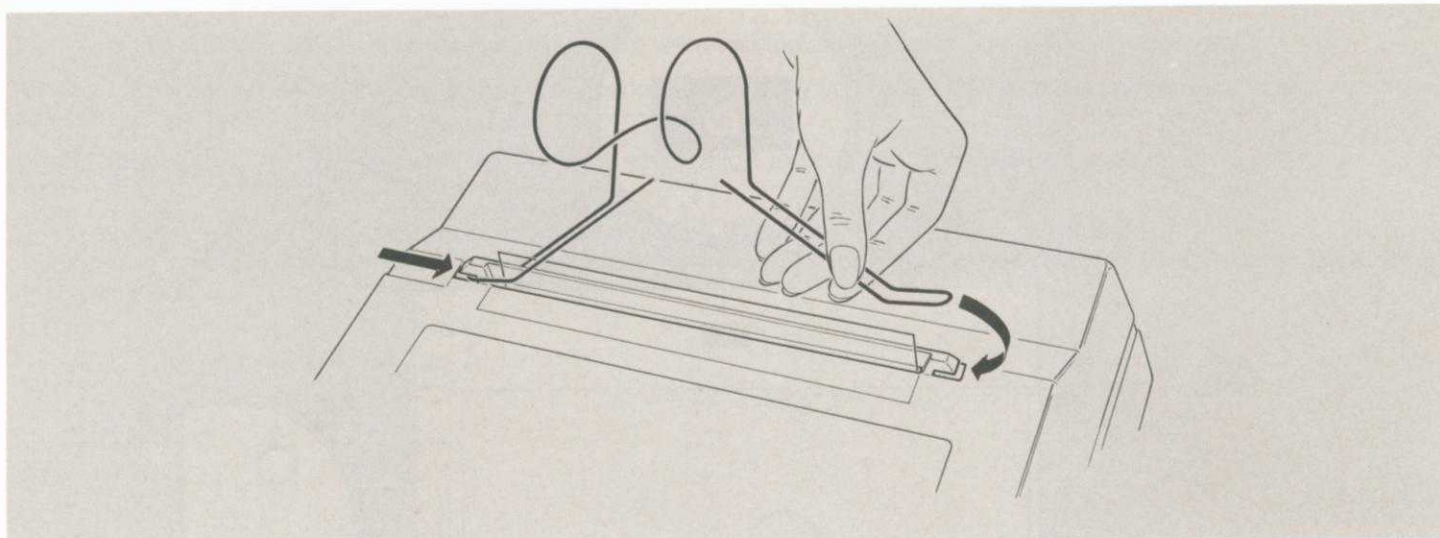

- Turn manual card advance dial away from you to allow the card/cover to be taken inside the programme-card guide.
- Set figure 1 of decorative design adjustment dial opposite to the reference mark.
- Turn manual card advance dial to bring any black or white square in column (3) inside the chosen motif opposite to pattern line indicator on selection box, visible through the card cover.
- Actuate automatic card advance switch by giving short upward ↑ movements until the buzzer sounds at beginning of motif. The number of motif is then opposite to line 1 of motif.

NOTA:

These movements are necessary to assure the advance of the programme-card in the appropriated sense. Each time the buzzer sounds, the direction of the programme-card is automatically reversed.

- Knit.
- Lay always the programme-cards and programme-card cover flat when not required; a folding would produce a wrong needle selection.

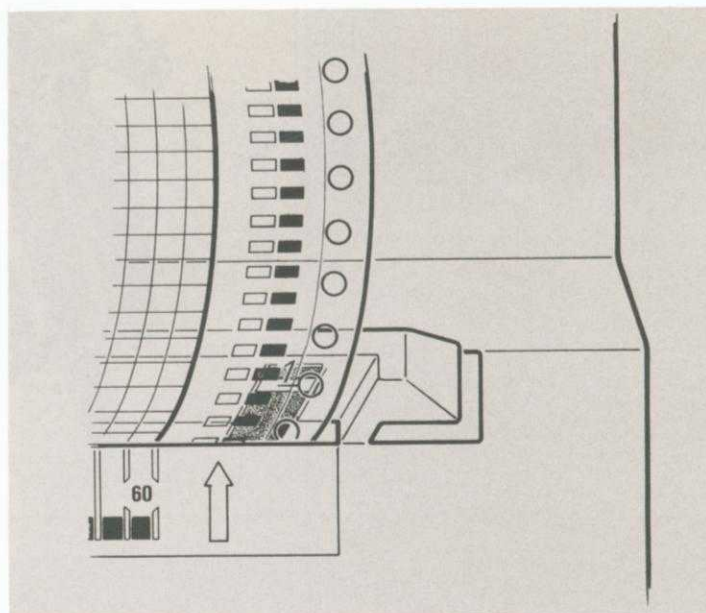

REMARK:

Patterns have been programmed to be knitted automatically either from the bottom to the top and back or only from the bottom to the top (see arrows on illustrated pattern chart). As soon as the buzzer sounds, knit one row. If it stops, carry on with knitting. If it does not stop, wait until the buzzer stops before continuing to knit.

When the row repeat switch is set in lower position  or in upper position  knit two rows as soon as the buzzer sounds. If it does not stop, wait until the buzzer stops before continuing to knit.

# IX. HOW TO USE THE SELECTION BOX WITH DECORATIVE PROGRAMME-CARD

## A. DESCRIPTION OF THE DECORATIVE PROGRAMME-CARD

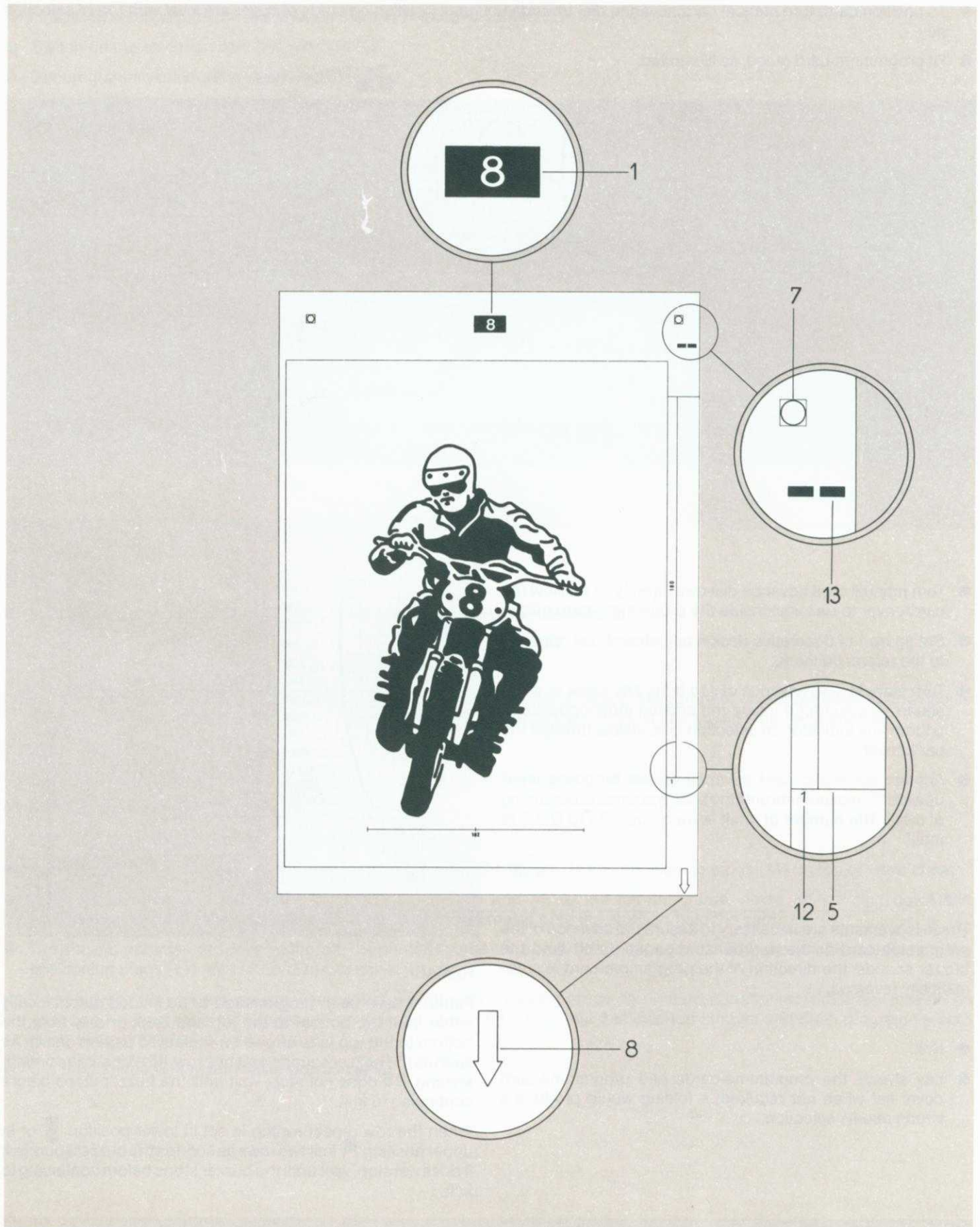



The card reference number is printed on top and in the middle of the card (mark 1).

The motif is drawn within the printed border which indicates the maximum width and height of motif.

To the right of the card are reference lines (5) indicating start and end of each motif.

The number of motif is indicated to the left of the starting point (12). To make setting and centralising of motif easier, the edges, the height in millimetres, the width as well as the centre of the design are indicated on the programme-card.

An arrow (8) is printed on the bottom of the card. It shows which way you have to insert the programme-card in the selection box.

On the upper part of the card are also two holes (7) which allow to position the card onto the studs of the programme-card cover (11).

On the top and to the right of the card are two black squares (13). If you have forgotten to switch off the selection box after the end of a motif, these squares will limit the programme-card travel and reverse it. It is accompanied by a warning light/buzzer signal. Switch off the selection box.

## B. DESCRIPTION OF THE PROGRAMME-CARD COVER

The purpose of this cover is to hold the programme-card. It is composed of two transparent plastic sheets sealed on the right-hand side. One plastic sheet is thinner than the other one.

The cover is also sealed at the bottom to get a better insertion into the selection box.

The cover has two vertical rows of perforations – oval ones (9) on the left-hand side, round ones (10) on the right-hand side – which are for the programme-card cover drive.

This cover also has two positioning studs (11) located near the top of the thicker sheet as well as two perforations (7) on the thinner sheet. These studs are used to position and maintain the card inside the cover.

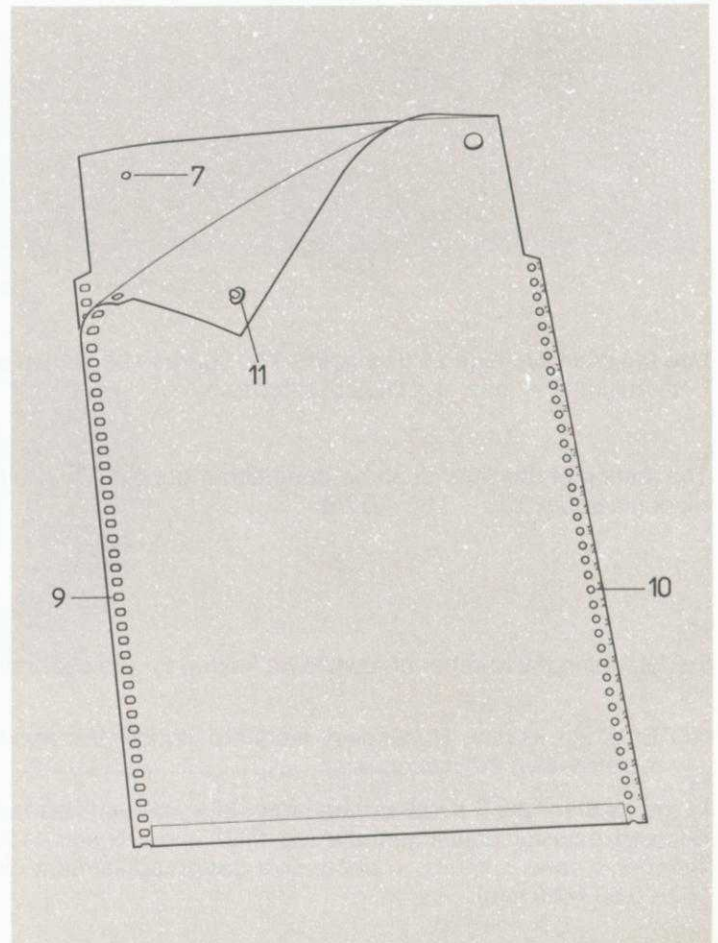

## C. TEST SAMPLE

To proportion the design to the required size you must knit a test sample in the pattern, with the yarn and settings which will be used to knit the garment.

NOTE: There could be a difference in comparison to the test sample according to the width of the garment and the number of weights to be used.

If for example, the test sample of 50 stitches has been knitted using one medium weight, use two medium weights for 100 stitches, three medium weights for 150 stitches, one large weight and two medium weights for 180 stitches.

- In the centre of the test sample count the number of stitches and rows per 10 cm.

NOTE: When knitting Norwegian Jacquard only count the number of stitches and rows **visible** in 10 cm order to find out the correct setting of the decorative design adjustment dial.

- Divide  $\frac{\text{the number of stitches per 10 cm}}{\text{the number of rows per 10 cm}}$  and set the nearest figure on the decorative adjustment dial opposite to the reference mark. (See illustration below.)

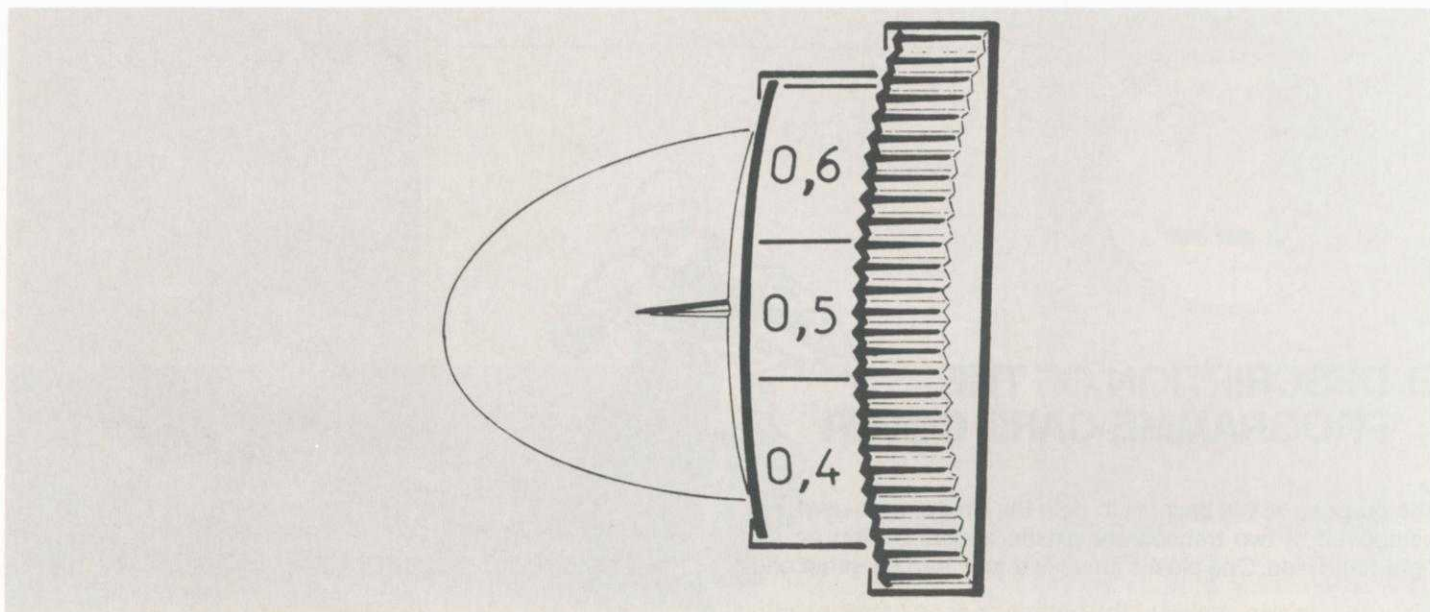

Use the chart on page 28 as a guide. The figure to be shown on  $\frac{2}{3}$  decorative design adjustment dial is given at the meeting of both columns of rows and lines of stitches.

The setting of this figure can be done either opposite to the figure (example 0.50 – 0.60 – 0.70) or opposite to the reference mark (example 0.55 – 0.65 – 0.75).

To determine the number of rows to be knitted for the decorative design divide  $\frac{\text{height of design in millimetres}}{\text{Figure set on decorative design adjustment dial}}$

NOTE: When knitting Norwegian Jacquard double the above number of rows as 1 row of Norwegian Jacquard = 2 rows registered on the row counter.

In the reverse way if a self-created decorative design has to be knitted on 100 rows, take into account the figure set on the decorative design adjustment dial (eg. 0,50) and proceed as follows:

Number of rows x figure on decorative design adjustment dial = height of design to be drawn on the programme-card (eg.  $100 \times 0.50 = 50 \text{ mm}$ ).

## D. USE OF THE DECORATIVE PROGRAMME-CARD

Before doing the following operations switch off the selection box.

- Switch on the selection box; it will light up.
- Set programme-changer in upper position .
- Set figure 0 of decorative design adjustment dial opposite to reference mark.
- Remove the programme-card guide if necessary.
- Choose the decorative programme-card showing the design of your choice.
- Take programme-card cover, oval perforations (9) to the right-hand side and positioning studs (11) on top of lower sheet.
- Insert programme-card into cover, **printed side below, arrow (8) pointing down** and position the card onto the studs. Fold back the sheet and press it onto the studs to hold the card.
- Turn the programme-card cover to the left. The printed figures can be read, the oval perforations (9) are on left-hand side and the positioning studs (11) are on top of upper sheet.
- Insert cover with programme-card into slot of selection box making arrow (8) on card correspond with arrow located on right-hand side of alignment reference on selection box. Make sure that it is inserted straight and push programme-card cover down until you feel the card grip.
- To position card, turn manual programme-card advance dial towards you until positioning studs of cover are level with top of selection box.
- Fit programme-card guide, as illustrated page 23.
- Turn manual programme-card advance dial away from you to allow the card/cover to be taken inside the programme-card guide.
- Using manual card advance dial, bring programme-card until the central mark of the design can be seen above programme-card insertion and alignment reference.
- Move cursor to bring white reference mark of a pattern-scanner opposite to the central mark of the design.

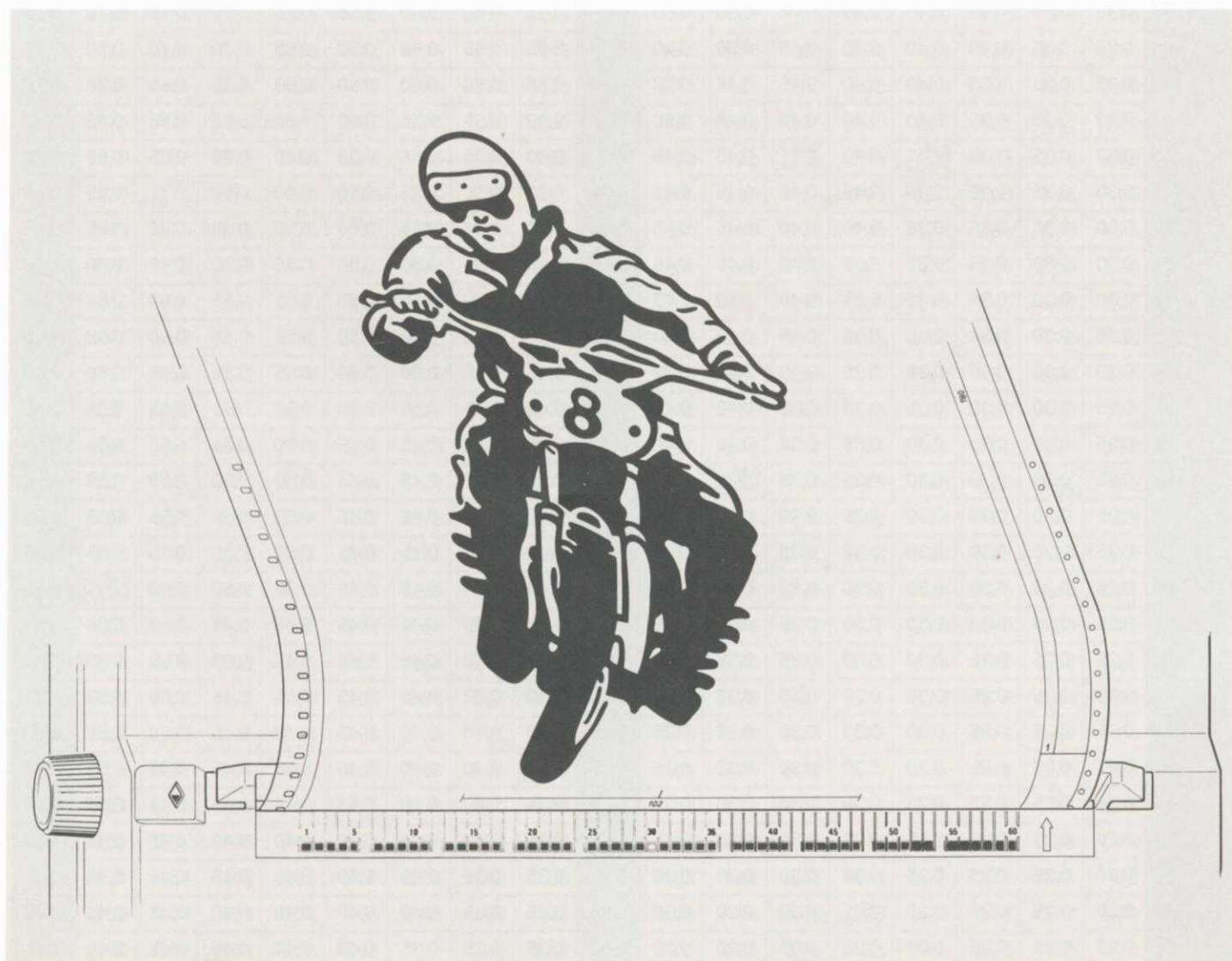

Stitches	15	16	17	18	19	20	21	22	23	24	25	26	27	28	29	30	31	32
Rows 23	0,65	0,70	0,75	0,80	0,85	0,90	0,95	1,00	1,05	1,10	1,15	1,20	1,25	1,30	1,30	1,35	1,40	1,45
24	0,65 0,60	0,65	0,70	0,75	0,80	0,85	0,90	0,95	1,00	1,05	1,10	1,15	1,20	1,20	1,25	1,30	1,35	1,40
25	0,60	0,65	0,70	0,70	0,75	0,85	0,90 0,85	0,90	0,95	1,00	1,05	1,10	1,15 1,10	1,15	1,20	1,25	1,30	1,35
26	0,60	0,60	0,65	0,70	0,75	0,80	0,85	0,90	0,90	0,95	1,00	1,05	1,10	1,10	1,15	1,20	1,25	1,30
27	0,55	0,60	0,65	0,65	0,70	0,75	0,80	0,85	0,90	0,90	0,95	1,00	1,05	1,10	1,10	1,15	1,20	1,25
28	0,55	0,55	0,60	0,65	0,70	0,75	0,80	0,80	0,85	0,90	0,95	0,95	1,00	1,05	1,10	1,10	1,15	1,20
29	0,50	0,55	0,60	0,60	0,65	0,70	0,75	0,80	0,80	0,85	0,90	0,95	0,95	1,00	1,05	1,05	1,10	1,15
30	0,50	0,55	0,55	0,60	0,65	0,70	0,70	0,75	0,80	0,85	0,85	0,90	0,95	0,95	1,00	1,05	1,05	1,10
31	0,50	0,50	0,55	0,60	0,60	0,65	0,70	0,75	0,75	0,80	0,80	0,85	0,90	0,95	0,95	1,00	1,05	1,05
32	0,45	0,50	0,55	0,55	0,60	0,65	0,70	0,70	0,75	0,80	0,80	0,85	0,85	0,90	0,95	0,95	1,00	1,05
33	0,45	0,50	0,50	0,55	0,60	0,65 0,60	0,65	0,70	0,70	0,75	0,80	0,80	0,85	0,90 0,85	0,90	0,95	0,95	1,00
34	0,45	0,45	0,50	0,55	0,55	0,60	0,65	0,65	0,70	0,75	0,75	0,80	0,80	0,85	0,90	0,90	0,95	0,95
35	0,45	0,45	0,50	0,50	0,55	0,60	0,60	0,65	0,70	0,70	0,75	0,75	0,80	0,80	0,85	0,90	0,90	0,95
36	0,40	0,45	0,45	0,50	0,55	0,55	0,60	0,65	0,65	0,70	0,70	0,75	0,80 0,75	0,80	0,85	0,85	0,90	0,90
37	0,40	0,45	0,45	0,50	0,50	0,55	0,60	0,60	0,65	0,65	0,70	0,70	0,75	0,80	0,80	0,85	0,85	0,90
38	0,40	0,40	0,45	0,45	0,50	0,55	0,55	0,60	0,60	0,65	0,70 0,65	0,70	0,75	0,75	0,80	0,80	0,85	0,85
39	0,40	0,40	0,45	0,45	0,50	0,50	0,55	0,60	0,60	0,65	0,65	0,70	0,70	0,75	0,75	0,80	0,80	0,85
40	0,40 0,35	0,40	0,45 0,40	0,45	0,50 0,45	0,50	0,55	0,55	0,60	0,60	0,65	0,65	0,70	0,70	0,75	0,75	0,80	0,80
41	0,35	0,40	0,40	0,45	0,45	0,50	0,55 0,50	0,55	0,60 0,55	0,60	0,65 0,60	0,65	0,70 0,65	0,70	0,75	0,75	0,80 0,75	0,80
42	0,35	0,40	0,40	0,45	0,45	0,50	0,50	0,55	0,55	0,60	0,60	0,65	0,65	0,70	0,75 0,70	0,75	0,75	0,80
43	0,35	0,35	0,40	0,40	0,45	0,50	0,50	0,55	0,55	0,55	0,60	0,60	0,65	0,65	0,70	0,70	0,75	0,75
44	0,35	0,35	0,40	0,40	0,45	0,45	0,50	0,55	0,55	0,55	0,60	0,60	0,65	0,65	0,70	0,70	0,70	0,75
45	0,35	0,35	0,40	0,40	0,40	0,45	0,50	0,50	0,50	0,55	0,55	0,60	0,60	0,65	0,70	0,70	0,70	0,75
46	0,35	0,35	0,35	0,40	0,40	0,45	0,45	0,50	0,50	0,55	0,55	0,60	0,60	0,60	0,65	0,65	0,70	0,70
47	0,30	0,35	0,35	0,40	0,40	0,45	0,45	0,50	0,50	0,50	0,55	0,55	0,60	0,60	0,65	0,65	0,65	0,70
48	0,30	0,35	0,35	0,40 0,35	0,40	0,45 0,40	0,45	0,45	0,50	0,50	0,55	0,55	0,55	0,60	0,60	0,65	0,65	0,70
49	0,30	0,35	0,35	0,35	0,40	0,40	0,45	0,45	0,50	0,50	0,50	0,55	0,55	0,60	0,60	0,65 0,60	0,65	0,65
50	0,30	0,30	0,35	0,35	0,40	0,40	0,45	0,45	0,45	0,50	0,50	0,55	0,55	0,55	0,60	0,60	0,65	0,65
51	0,30	0,30	0,35	0,35	0,35	0,40	0,40	0,45	0,45	0,50	0,50	0,50	0,55	0,55	0,60	0,60	0,60	0,65
52	0,30	0,30	0,35	0,35	0,35	0,40	0,40	0,45	0,45	0,45	0,50	0,50	0,55	0,55	0,55	0,60	0,60	0,65
53	0,30	0,30	0,30	0,35	0,35	0,40	0,40	0,40	0,45	0,45	0,50	0,50	0,50	0,55	0,55	0,60	0,60	0,60
54	0,30	0,30	0,30	0,35	0,35	0,40	0,40	0,40	0,45	0,45	0,45	0,50	0,50	0,55	0,55	0,60	0,60	0,60
55	0,25	0,30	0,30	0,35	0,35	0,35	0,40	0,40	0,45 0,40	0,45	0,45	0,50	0,50	0,50	0,55	0,55	0,55	0,60
56	0,25	0,30	0,30	0,30	0,35	0,35	0,40	0,40	0,40	0,45	0,45	0,45	0,45	0,50	0,55	0,55	0,55	0,60
57	0,25	0,30	0,30	0,30	0,35	0,35	0,40 0,35	0,40	0,40	0,45	0,45	0,45	0,45	0,50	0,50	0,55	0,55	0,55
58	0,25	0,30	0,30	0,30	0,35	0,35	0,35	0,40	0,40	0,40	0,45	0,45	0,45	0,50	0,50	0,55	0,55	0,55
59	0,25	0,25	0,30	0,30	0,30	0,35	0,35	0,40	0,40	0,40	0,45	0,45	0,45	0,50	0,50	0,50	0,55	0,55
60	0,25	0,25	0,30	0,30	0,30	0,35	0,35	0,35	0,40	0,40	0,40	0,45	0,45	0,50	0,50	0,50	0,55 0,50	0,55
61	0,25	0,25	0,30	0,30	0,30	0,35	0,35	0,35	0,35	0,40	0,40	0,40	0,45	0,45	0,45	0,50	0,50	0,55
62	0,25	0,25	0,25	0,30	0,30	0,35	0,35	0,35	0,40	0,40	0,40	0,45	0,45	0,45	0,50	0,50	0,50	0,50
63	0,25	0,25	0,25	0,30	0,30	0,30	0,35	0,35	0,35	0,40	0,40	0,40	0,45	0,45	0,45	0,50	0,50	0,50
64	0,25	0,25	0,25	0,30	0,30	0,30	0,35	0,35	0,35	0,40	0,40	0,40	0,45	0,45	0,45	0,50	0,50	0,50
65	0,25	0,25	0,25	0,30	0,30	0,30	0,35	0,35	0,35 0,35	0,40 0,35	0,40	0,40	0,40	0,45	0,45	0,45	0,50	0,50
66	0,25	0,25	0,25	0,25	0,30	0,30	0,30	0,35	0,35	0,35	0,40	0,40	0,40	0,45	0,45	0,45	0,50	0,50
67	0,20	0,25	0,25	0,25	0,30	0,30	0,30	0,35	0,35	0,35	0,40	0,40	0,40	0,40	0,45	0,45	0,45	0,50
68	0,20	0,25	0,25	0,25	0,30	0,30	0,30	0,30	0,35	0,35	0,35	0,40	0,40	0,40	0,45	0,45	0,45	0,45
69	0,20	0,25	0,25	0,25	0,25 0,30	0,30	0,30	0,30	0,35	0,35	0,35	0,40	0,40	0,40	0,40	0,45	0,45	0,45
70	0,20	0,25	0,25	0,25	0,25	0,30	0,30	0,30	0,35	0,35	0,35	0,35	0,40	0,40	0,40	0,45	0,45	0,45

33	34	35	36	37	38	39	40	41	42	43	44	45	46	47	48	49	50	Stitches
1,50	1,55	1,60																23 Rows
1,45	1,50	1,50	1,55	1,60														24
1,40 1,35	1,40	1,45	1,50	1,55	1,60													25
1,30	1,35	1,40	1,45	1,50	1,50	1,55	1,60											26
1,25	1,30	1,35	1,40	1,40	1,45	1,50	1,55	1,60										27
1,20	1,25	1,30	1,35	1,35	1,40	1,45	1,50	1,50	1,55	1,60								28
1,20	1,20	1,25	1,30	1,30	1,35	1,40	1,45	1,45	1,50	1,55	1,55	1,60						29
1,15	1,15	1,20	1,25	1,30	1,30	1,35	1,40	1,40	1,45	1,50	1,50	1,55	1,60					30
1,10	1,15	1,15	1,20	1,25	1,25	1,30	1,35	1,35	1,40	1,45	1,45	1,50	1,55	1,55	1,60			31
1,05	1,10	1,15	1,15	1,20	1,25 1,20	1,25	1,30	1,30	1,35	1,40	1,40	1,45	1,50	1,50	1,55	1,60	1,60	32
1,05	1,05	1,10	1,15 1,10	1,15	1,20	1,20	1,25	1,30	1,30	1,35	1,40 1,35	1,40	1,45	1,45	1,50	1,55	1,55	33
1,00	1,05	1,05	1,10	1,10	1,15	1,20	1,20	1,25	1,25	1,30	1,35	1,35	1,40	1,40	1,45	1,50	1,50	34
0,95	1,00	1,05	1,05	1,10	1,10	1,15	1,20 1,15	1,20	1,25	1,25	1,30	1,30	1,35	1,40	1,40	1,45	1,45	35
0,95	0,95	1,00	1,05	1,05	1,10	1,10	1,15 1,20	1,20	1,25	1,25	1,30	1,30	1,35	1,40 1,35	1,40	1,45	1,45	36
0,90	0,95	0,95	1,00	1,05	1,05	1,10	1,10	1,15	1,15	1,20	1,20	1,25	1,30	1,30	1,35	1,35	1,40	37
0,90	0,90	0,95	0,95	1,00	1,05	1,05	1,10	1,10	1,15	1,15	1,20	1,20	1,25	1,25	1,30	1,30	1,35	38
0,85	0,90	0,90	0,95	0,95	1,00	1,05	1,05	1,10	1,10	1,15	1,15	1,20	1,20	1,25	1,25	1,30	1,30	39
0,85	0,85	0,90	0,90	0,95	0,95	1,00	1,05	1,05	1,10	1,15	1,15	1,15	1,20	1,20	1,25	1,25	1,30	40
0,85 0,80	0,85	0,90 0,85	0,90	0,95 0,90	0,95	0,95	1,00	1,05	1,05	1,10 1,05	1,10	1,15 1,10	1,15	1,20 1,15	1,20	1,25 1,20	1,25	41
0,80	0,85	0,85	0,90	0,90	0,95	0,95	0,95	1,00	1,05	1,05	1,05	1,10	1,10	1,15	1,20	1,20	1,20	42
0,80	0,80	0,85	0,85	0,90	0,90	0,95	0,95	0,95	1,00	1,05	1,05	1,05	1,10	1,10	1,15	1,15	1,20	43
0,80	0,80	0,80	0,85	0,85	0,90	0,90	0,95	0,95	0,95	1,00	1,05	1,05	1,05	1,10	1,10	1,15	1,15	44
0,75	0,75	0,80	0,80	0,85	0,85	0,90	0,90	0,95	0,95	0,95	1,00	1,05	1,05	1,05	1,10	1,10	1,15	45
0,75	0,75	0,80	0,80	0,80	0,85	0,85	0,90	0,90	0,95	0,95	1,00	1,05	1,05	1,05	1,10	1,10	1,10	46
0,70	0,75	0,75	0,80	0,80	0,85	0,85	0,85	0,90	0,90	0,95	0,95	0,95	1,00	1,05	1,05	1,05	1,10	47
0,70	0,70	0,75	0,75	0,80	0,80	0,85	0,85	0,85	0,90	0,90	0,95	0,95	0,95	1,00	1,05	1,05	1,05	48
0,70	0,70	0,75	0,75	0,75	0,80	0,80	0,85	0,85	0,90 0,85	0,90	0,90	0,95	0,95	0,95	1,00	1,05	1,05	49
0,70	0,70	0,70	0,75	0,75	0,80 0,75	0,80	0,80	0,85	0,85	0,90	0,90	0,90	0,95	0,95	0,95	1,00	1,05	50
0,65	0,70	0,70	0,70	0,75	0,75	0,80	0,80	0,80	0,85	0,85	0,90	0,90	0,90	0,95	0,95	0,95	1,00	51
0,65	0,65	0,70	0,70	0,75 0,70	0,75	0,75	0,80	0,80	0,80	0,85	0,85	0,90	0,90	0,90	0,95	0,95	0,95	52
0,65	0,65	0,65	0,70	0,70	0,75	0,75	0,75	0,80	0,80	0,85	0,85	0,85	0,90	0,90	0,90	0,95	0,95	53
0,60	0,65	0,65	0,70	0,70	0,70	0,75	0,75	0,75	0,80	0,80	0,85	0,85	0,85	0,90	0,90	0,90	0,95	54
0,60	0,60	0,65	0,65	0,70	0,70	0,70	0,75	0,75	0,80	0,80	0,80	0,85	0,85	0,85	0,90	0,90	0,95 0,90	55
0,60	0,60	0,65	0,65	0,70	0,70	0,70	0,75	0,75	0,80	0,80	0,80	0,85	0,85	0,85	0,90	0,90	0,90	56
0,60	0,60	0,65 0,60	0,65	0,65	0,70	0,70	0,70	0,75	0,75	0,75	0,80	0,80	0,80	0,85	0,85	0,90 0,85	0,90	57
0,60	0,60	0,60	0,65	0,65	0,65	0,70	0,70	0,70	0,75	0,75	0,75	0,80	0,80	0,80	0,85	0,85	0,90	58
0,55	0,60	0,60	0,60	0,65	0,65	0,65	0,70	0,70	0,70	0,75	0,75	0,75	0,80 0,75	0,80	0,80	0,85	0,85	59
0,55	0,60	0,60	0,60	0,65	0,65	0,65	0,70	0,70	0,70	0,75	0,75	0,75	0,80	0,80	0,80	0,85	0,85	60
0,55	0,55	0,60	0,60	0,60	0,65	0,65	0,65	0,70	0,70	0,70	0,75	0,75	0,75	0,80	0,80	0,80	0,85	61
0,55	0,55	0,55	0,60	0,60	0,60	0,60	0,65	0,65	0,70	0,70	0,70	0,75 0,70	0,75	0,75	0,75	0,80	0,80	62
0,50	0,55	0,55	0,55	0,60	0,60	0,60	0,65 0,60	0,65	0,65	0,70	0,70	0,70	0,75	0,75	0,75	0,80	0,80	63
0,50	0,55	0,55	0,55	0,55	0,60	0,60	0,60	0,65	0,65	0,65	0,70	0,70	0,70	0,75	0,75	0,75	0,80	64
0,50	0,55	0,55	0,55	0,55	0,60 0,55	0,60	0,60	0,60	0,65	0,65	0,70	0,70	0,70	0,70	0,75	0,75	0,75	65
0,50	0,50	0,55	0,55	0,55	0,55	0,60	0,60	0,60	0,65	0,65	0,70	0,70	0,70	0,70	0,75	0,75	0,75	66
0,50	0,50	0,50	0,55	0,55	0,55	0,55	0,60	0,60	0,60	0,65	0,65	0,65	0,70	0,70	0,70	0,70	0,75	67
0,50	0,50	0,50	0,50	0,55	0,55	0,55	0,60	0,60	0,60	0,65	0,65	0,65	0,70	0,70	0,70	0,70	0,75	68
0,50	0,50	0,50	0,50	0,55	0,55	0,55	0,60	0,60	0,60	0,60	0,65	0,65	0,65	0,70	0,70	0,70	0,70	69
0,45	0,50	0,50	0,50	0,55	0,55	0,55	0,55	0,60	0,60	0,60	0,65	0,65	0,65	0,65	0,70	0,70	0,70	70

NOTE: If you want to set your design at another place, follow the instructions given on page 17 (setting of a design).

- Set programme-changer in neutral position ○.
- Bring centre of cursor opposite to 0 on the graduated scale.
- Set programme-changer in upper position  : the design is set in the centre of the garment.
- Bring cursor to same side as carriage.
- Set opposite to reference mark on decorative design adjustment dial the result of the division  $\frac{\text{number of stitches per 10 cm}}{\text{number of rows per 10 cm}}$  found on chart shown on page 28.
- Bring starting line visible on the programme-card opposite to pattern-line indicator visible through the programme-card cover.

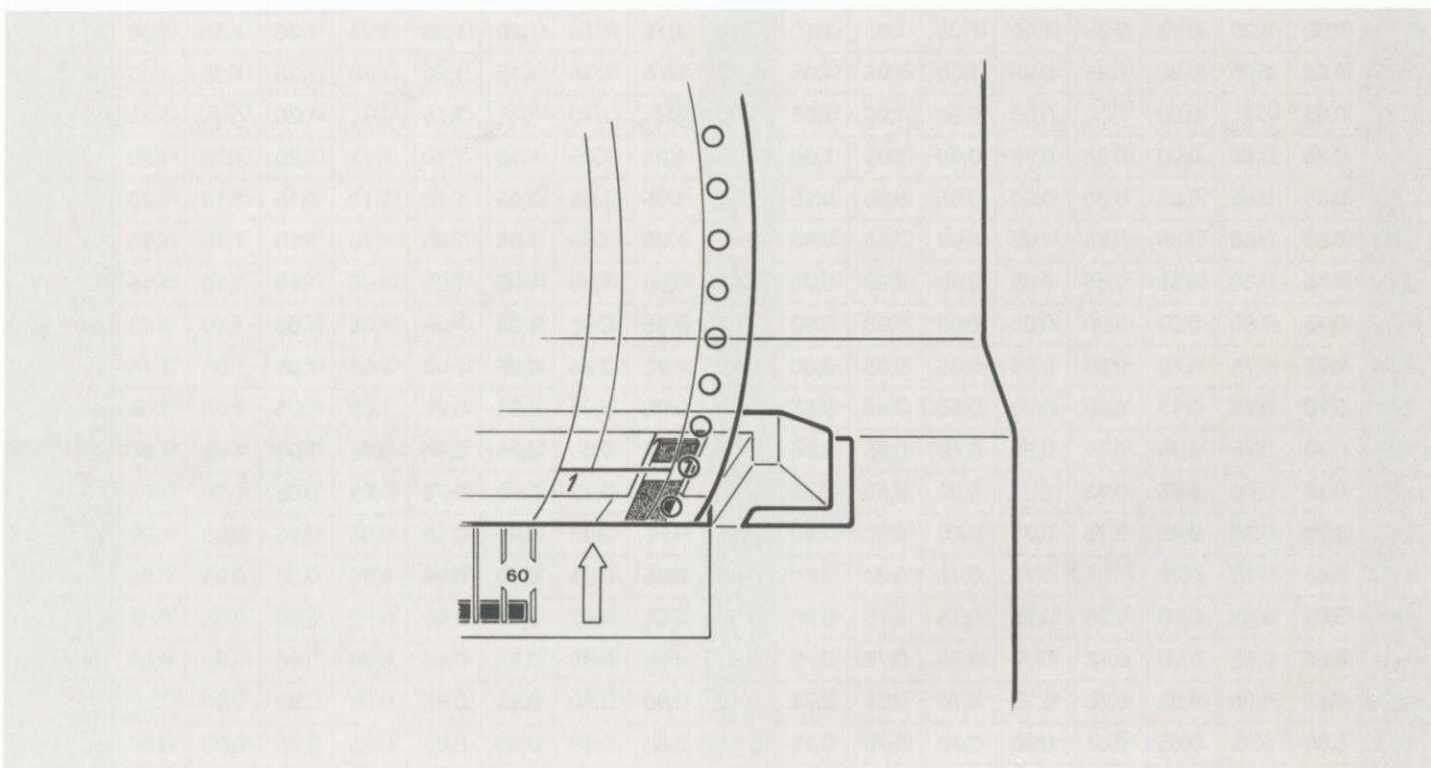

- Actuate the automatic card advance switch by giving one short downward ↓ movement.

NOTE: This movement is necessary to assure the advance of the programme-card in the appropriated sense.

REMARK: The design is completed when the second yarn is no more knitted. Ending of motif is then approximatively opposite to pattern line indicator on the box.

- Knitting instructions are given on page 35.
- Lay always the programme-cards and programme-card cover flat when not required; a folding would produce a wrong needle selection.

# X. ILLUSTRATED PATTERN CHART

The knitting possibilities which do not need a programme-card are illustrated on both sides of a separate sheet as well as the necessary settings.

These patterns have reference "A" which you will find in the left-hand corner on the picture of each pattern.

The other illustrated charts are classified by pattern type. This classification is represented by a roman figure which is found on top of chart:

- Tuck knitting I
- Slip stitch knitting II
- Fair Isle III
- Jacquard method 1 IV
- Jacquard method 2 V
- Jacquard method 3 VI
- Norwegian Jacquard VII
- Weaving effect VIII
- Patterns with needles in holding position IX
- Garter Stitches X
- Lace stitches XI

The different settings and accessories which are necessary to knit the pattern are illustrated below the pattern.

Different numbers are shown on each picture of the pattern.

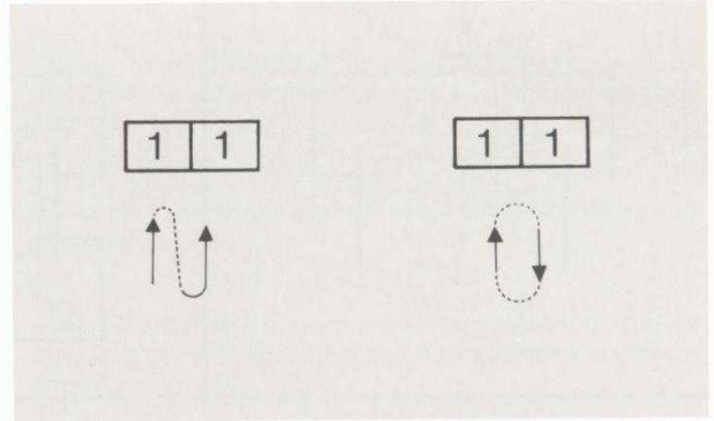



The left-hand square corresponds to the number of the geometric or decorative programme-card on which is printed the design.

The second square corresponds to the number of the design shown on a geometric or decorative programme-card.

Below these numbers is shown one of the following symbol.



The symbol  indicates that the design is always knitted from the bottom to the top. The knitting must be stopped during the rapid return of the geometric programme-card.

The symbol  indicates that the design is knitted continuously from bottom to top and back from top to bottom.

## Thickness of yarn

A = fine

B = medium

C = heavy

D = for weaving effect



**Settings on carriages:**

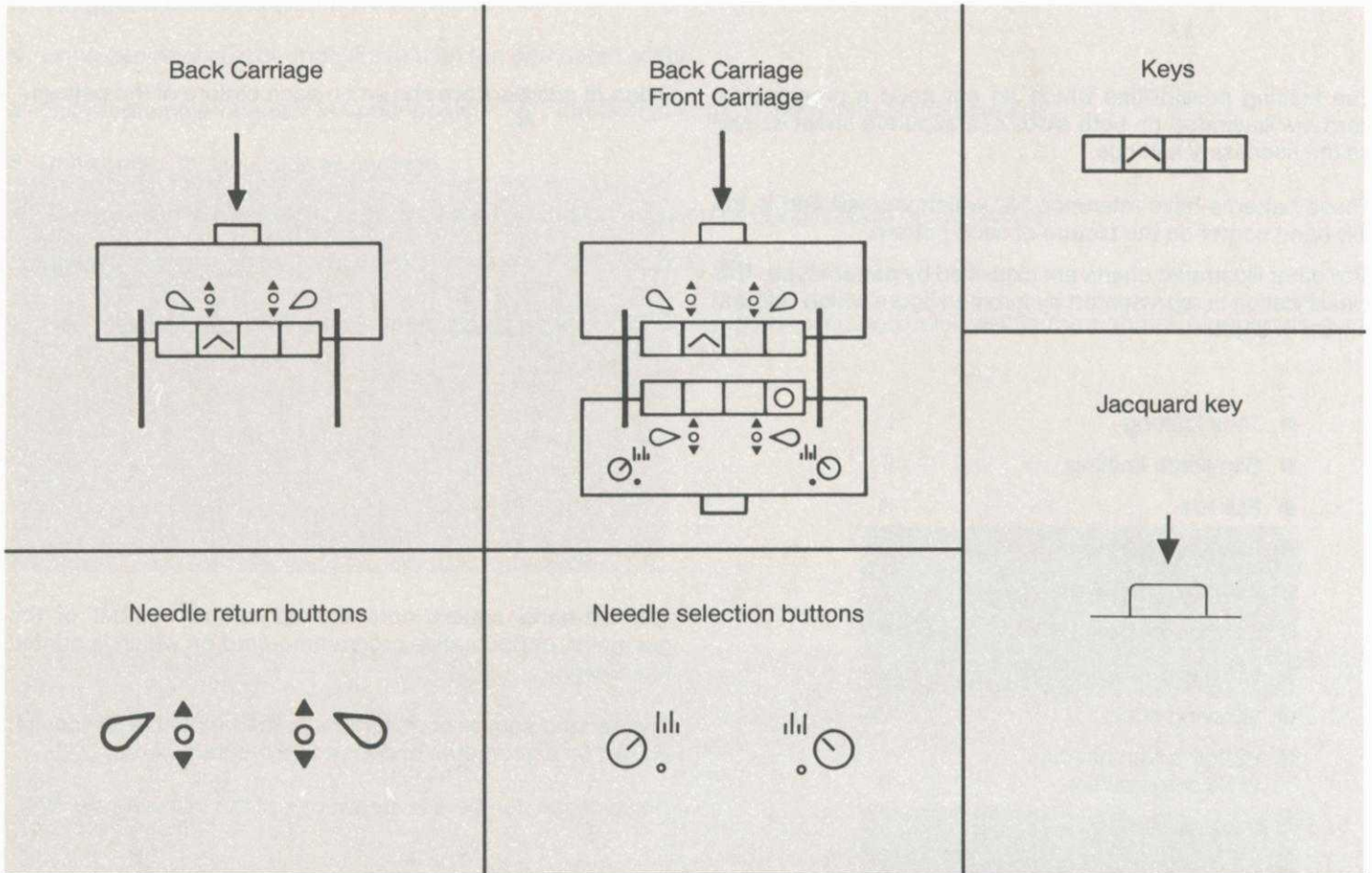

**Settings on Selection box**

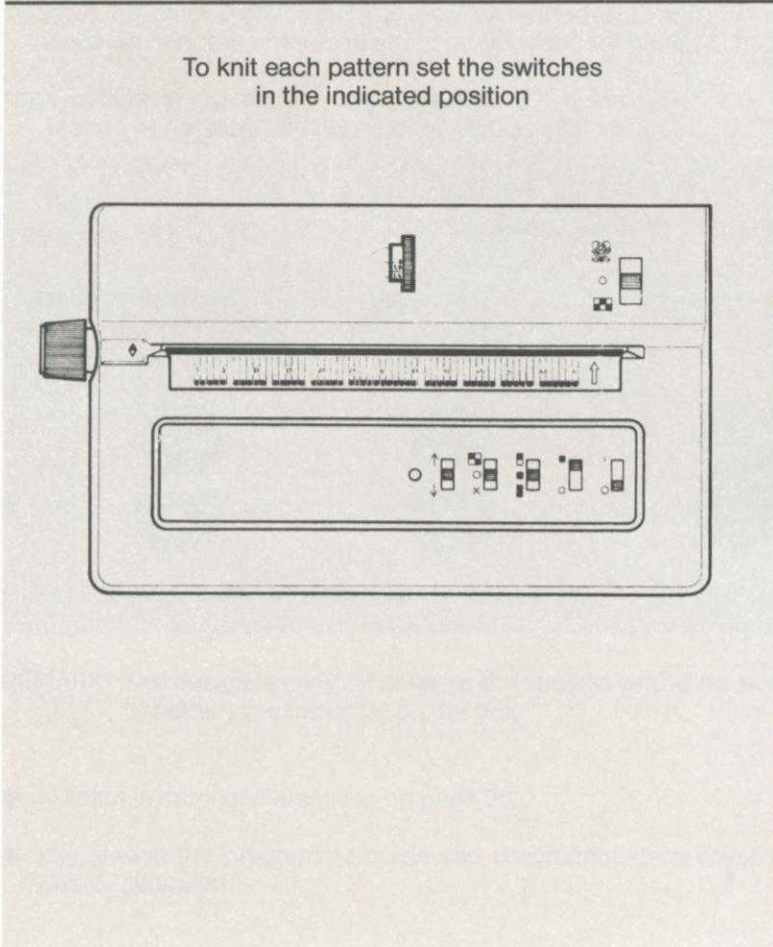

**ACCESSORIES:**

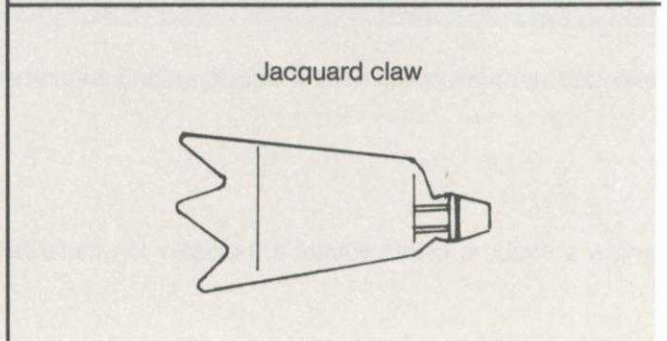
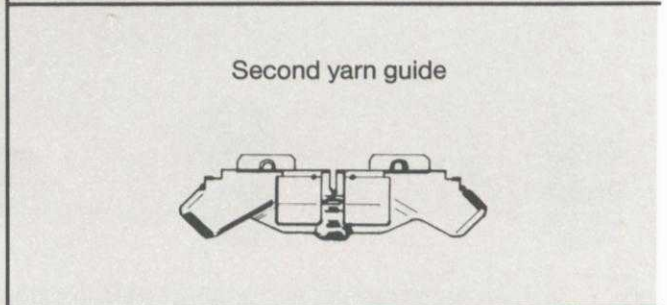
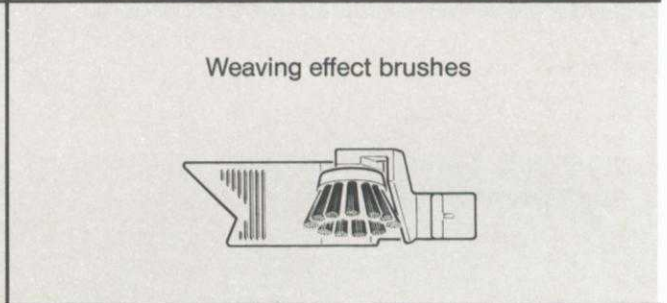



# XI. SOME HINTS

## Before Knitting

1. An audible click can be heard when the cursor is disengaged at the end of a row. Do not start back in the opposite direction with the carriages until you have heard this disengagement click.

When using the motor-drive, move eventually the inversion keys one perforation further.

2. Before knitting, make sure that:

- Starting line of design is opposite to pattern-line indicator on the box, visible through the programme-card cover.
- Cursor is on the same side as the carriage.
- Cursor and cursor stops are correctly positioned according to type of knitting.

3. Should you wish to reverse the direction of knitting of a symmetric pattern, bring programme-card with short movements actuating the automatic card advance switch from the begin of the pattern until the buzzer sounds at the last row of pattern.

## During Knitting

### 4. With geometric programme-card

If you should leave the knitting for a short period, do not switch off the selection box. You may resume knitting as required.

If you should leave the knitting for a longer period, it is more accurate to stop knitting **at the beginning of your pattern** when the buzzer sounds. When you resume knitting, actuate the automatic card advance switch by giving two short downward ↓ movements and two short upward ↑ movements.

If you should leave the knitting for a longer period, **during pattern**, note the pattern row on your card and the card direction.

Switch off the selection box ○ and remove power lead. When you resume knitting, replace power lead and switch on | the selection box. Bring as previously noted, pattern row opposite to pattern-line indicator visible through the programme-card cover. Actuate the automatic card advance switch by giving two short movements in the opposite card direction to the one stated previously and two short movements in the same direction as noted previously.

### 5. With decorative programme-card

If you should leave the knitting for a short period, do not switch off ○ the selection box. You may resume knitting as required.

If you should leave the knitting for a longer period, switch off ○ the selection box and remove power lead. When you resume knitting, replace power lead and switch on | selection box. Actuate the automatic card advance switch by giving two short movements in the opposite card direction and two short movements in the required direction.

6. If for any reason you have to change the position of cursor and cursor stops, bring carriage at the end of the needle bed.

7. During the rapid return of the programme-card, stop knitting until the buzzer has stopped and the programme-card has returned.

8. Re-position cursor and cursor stops when increasing and decreasing.

9. When increasing or decreasing, move the needles or needle groups in working position 2 to assure the correct knitting.

### 10. Shaping necklines and shoulder seams

Some knitting possibilities e.g. two-colour work, patterns with needles in holding position, lace and fancy garter stitches do not allow to place needles into holding position when dividing the garment for shaping.

Therefore, choose one of the **four** following methods:

a) Using the double ended eyelet needle thread an auxiliary yarn through the stitches to be removed.

b) Knit several rows with an auxiliary yarn and release stitches from the needles.

c) Take the stitches to be removed and place them either on a hand knitting needle or on a safety pin.

d) Transfer the back bed stitches onto the opposite front bed needles.

- To knit the second side of the garment, make sure to re-hang the stitches on exactly the same needles in order to keep the continuity of the pattern.

- Set row counter on the same number when dividing the garment.

11. When dividing the knitting, neckline as an example, make a note of the pattern row on which you stop knitting and the direction of programme-card on direction indicator.

To knit the second side of the knitting, actuate the automatic card advance switch and give the necessary short movements to bring the card onto the pattern row noted previously in the required card direction.

12. Use edge claws and weights if necessary.

### 13. Single design in Fair Isle:

To avoid a space on the edge of the design, proceed as follows:

- On carriage side, slightly move the first needle knitting the main yarn without making slide the stitch beyond the latch.
- Pass the second yarn under the needle and loop it back towards the left if carriage is on the right-hand side, pass it under the needle and lay it onto the front flow combs.
- Take the needle by the heel and lower it in position 1. When the carriage is moved across, the second yarn will be bound with the main yarn.

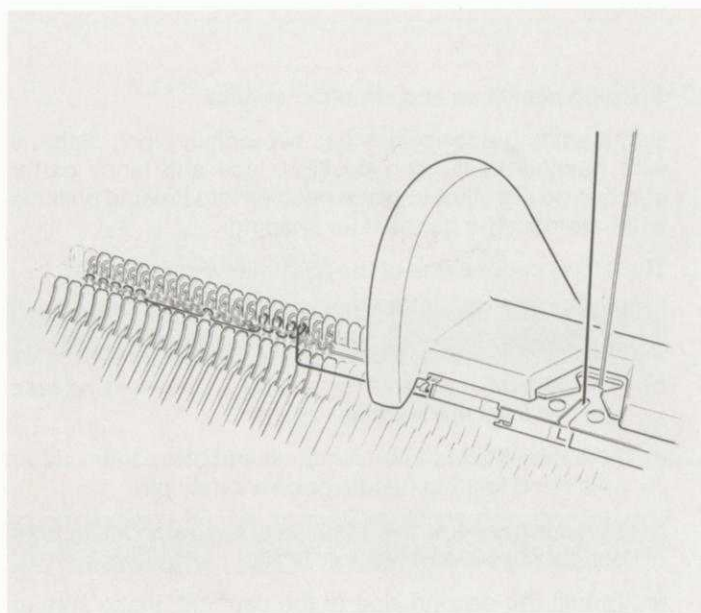

- Do not move the carriage to fast.
- Repeat this operation after each row.

14. If you want to knit plain stocking stitch between bands knitted in Fair Isle:

- Switch off the selection box
- Cancel key  and Jacquard key
- Depress key
- Knit the necessary number of rows.
- When you start again in Fair Isle, do not forget to do the correct settings on the carriage and selection box.

### After knitting

15. If you are not using the selection box:

- Remove power lead.

16. Always remove second yarn guide when moving the carriages across empty needles.

17. After completing work, cancel Jacquard keys and remove accessories used when knitting fancy patterns.

18. Always carefully cover your machine to protect it from dust.

# XII. HOW TO KNIT

## TUCK KNITTING (I)



- Choose thickness of yarn as advised on illustrated pattern charts.
- Cast on to your choice. Before starting to knit pattern, transfer all stitches from the front bed onto the back bed needles.
- Carriage on right-hand side.
- Key .
- Needle return buttons ●—●—●.
- Stocking stitch size.
- Space selector 5.
- Flow combs opposite.
- Front bed in upper position.
- Connect power lead to the selection box.
- Switch on the selection box | .
- Insert the geometric programme-card showing the design of your choice (see page 22).
- Position cursor and cursor stops (see page 10).
- Centralise your design (see page 15 "Setting of a design").
- Push cursor against right-hand stop.
- Set the switches of the selection box as indicated on the illustrated pattern chart according to the design.
- Position starting line of your design opposite to pattern-line indicator visible through the programme-card cover.
- Actuate the automatic card advance switch by giving two short upward ↑ movements.
- Knit.

### IMPORTANT:

Should you leave your knitting, stop carriage on right-hand side. For any other advice, refer to hint No. 4, page 33.

### NOTE FOR SINGLE BED:

- After casting on knit 4 or 5 rows slightly pulling on the mounting comb.

Before attaching the knitting retainer:

- Remove both central wheels by pushing them forwards. A better result can be obtained when using weights.

## SLIP STITCH KNITTING (II)



- Choose thickness of yarn as advised on illustrated pattern charts.
- Cast on to your choice. Before starting to knit your pattern, transfer all stitches from the front bed onto the back bed needles.
- Carriage on right-hand side.
- Key  (keys cancelled).
- Needle return buttons ●—●—●.
- Stocking stitch size.
- Space selector 5.
- Flow combs opposite.
- Front bed upper position.
- Connect power lead to the selection box.
- Switch on the selection box | .
- Insert the geometric programme-card showing the design of your choice (see page 22).

- Position cursor and cursor stops (see page 10).
- Centralise your design (see page 15, "Setting of a design").
- Push cursor against right-hand stop.
- Set the switches of the selection box as indicated on the illustrated pattern charts according to design.
- Position starting line of your design opposite to pattern-line indicator visible through the programme-card cover.
- Actuate the automatic card advance switch by giving two short upward ↑ movements.
- Knit.

**IMPORTANT:**

Should you leave your knitting, stop carriage on right-hand side. For any other advice, refer to hint No. 4, page 33.

**NOTE FOR SINGLE BED:**

- After casting-on knit 4 or 5 rows slightly pulling on the mounting comb.

Before attaching the knitting retainer:

- Remove both central wheels by pushing them forwards.

A better result can be obtained when using weights.





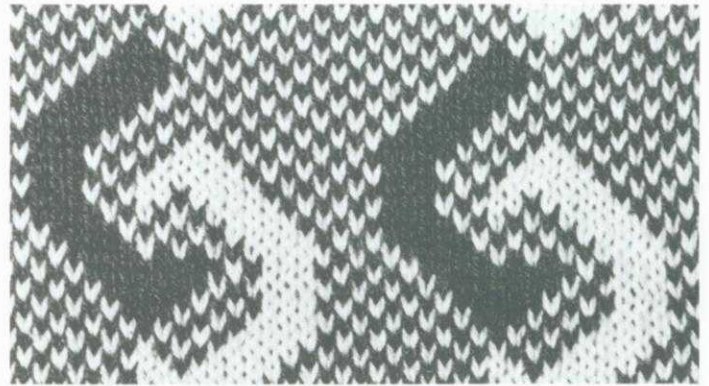

**FAIR ISLE (III)**

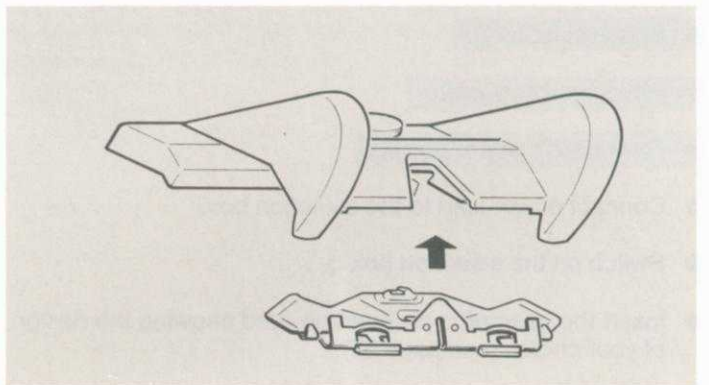

The second yarn guide allows you to create a wide variety of beautifully coloured patterns in one passage of the carriage.

- Choose thickness of yarn as advised on illustrated pattern charts.
- Cast on to your choice. Before starting to knit your pattern, transfer all stitches from the front bed onto the back bed needles.
- Carriage on right-hand side.
- Fit second yarn guide.



- Thread machine with second yarn and fix it **to the left-hand clamp**.
- Depress simultaneously  key  and Jacquard key.
- Needle return buttons in upper position .
- Stocking stitch size increased by 1 or 2 sizes.
- Space selector 3.
- Flow combs opposite.
- Front bed normal position.
- Connect power lead to the selection box.
- Switch on the selection box .

- Insert either a geometric or a decorative programme-card showing the design of your choice (see page 22 and 27).
- Position cursor and cursor stops (see page 10).
- Set your design (see page 15, "Setting of a design").
- Push cursor against right-hand stop.
- Set figure on decorative design adjustment dial opposite to reference mark.
- Set the stitches of the selection box as indicated on the illustrated pattern charts according to design.
- Position starting line of your design opposite to pattern-line indicator visible through the programme-card cover.
- Actuate the automatic card advance switch by giving two upward ↑ movements when using a geometric programme-card – or give one short downward ↓ movement when using a decorative programme-card.
- Knit.
- When the pattern is finished, remove second yarn guide.

#### IMPORTANT:

1. When using the second yarn guide, do not bring needles into holding position 3, they would be automatically recalled by the Jacquard key.
2. Should you leave your knitting, stop carriage on right-hand side. For any other advice, refer to hint No. 4 or 5 page 33, according to design.
3. To knit necklines, refer to hint No. 12 and 13, page 33.

#### NOTE:

The purl side of Fair Isle will show of course floating threads. Choose therefore designs accordingly or set automatic row advance stop/every other needle selector switch in upper position  in order to obtain an automatic selection of every other needle in all white sections of the programme-card.





#### NOTE FOR SINGLE BED:

- After casting-on knit 4 or 5 rows slightly pulling on the mounting comb.
- Before attaching the knitting retainer:
- Remove both central wheels by pushing them forwards.
  - Thread carriage yarn guide with main yarn.
  - Fit second yarn guide.
  - Hold knitting retainer behind main yarn, and bring it in front of carriage and attach it.
- A better result can be obtained when using weights.



## SINGLE DESIGN IN FAIR ISLE



- Choose thickness of yarn as advised on illustrated pattern charts.
- Cast on to your choice. Before starting to knit your design, transfer all stitches from the front bed onto the back bed needles.
- Carriage on right-hand side.
- Fit second yarn guide.
- Thread machine with second yarn and fix it **to the left-hand clamp**.
- Depress simultaneously key  and Jacquard key .
- Needle return buttons in upper position .
- Stocking stitch size increased by 1 or 2 sizes.
- Space selector 3.
- Flow combs opposite.
- Front bed normal position.
- Connect power lead to the selection box.
- Switch on the selection box .
- Insert either a geometric or a decorative programme-card showing the design of your choice (see page 22 and 27).
- Position cursor and cursor stops (see page 10).
- Set your design (see page 15 "Setting of a design").
- Push cursor against right-hand stop.
- Set figure on decorative design adjustment dial opposite to reference mark.
- Set the switches of the selection box as indicated on the illustrated pattern charts according to design.

- Position starting line of your design opposite to pattern-line indicator visible through the programme-card cover.
- Actuate the automatic card advance switch by giving two upward ↑ movements when using a geometric programme-card – or give one short downward ↓ movement when using a decorative programme-card.
- Knit.
- Rehang edge weights and claws every 10 rows.
- When the pattern is finished, remove second yarn guide.

#### NOTE:

You can also set the automatic row advance stop/every other needle selector switch in upper position  in order to obtain an automatic selection of every other needle in all white sections of the programme-card.

#### IMPORTANT:

1. When using the second yarn guide, do not bring needles into holding position 3, they would be automatically recalled by the Jacquard key.
2. Should you leave your knitting, stop carriage on right-hand side. For any other advice, refer to hint No. 4 or 5, page 33 according to design.
3. A single design should always be knitted with reverser . If you want to reverse the colours, make sure to change the yarns in the yarn guides.

#### NOTE FOR SINGLE BED:

- After casting on knit 4 or 5 rows slightly pulling on the mounting comb.

Before attaching the knitting retainer:

- Remove both central wheels by pushing them forwards.
- Thread carriage yarn guide with main yarn.
- Fit second yarn guide.
- Hold knitting retainer behind main yarn, and bring it in front of carriage and attach it.







A better result can be obtained when using weights.

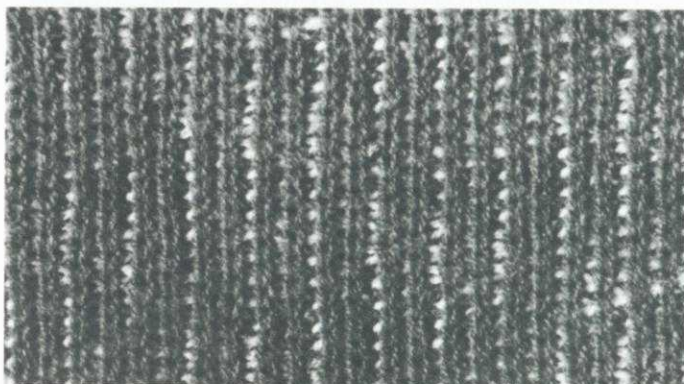
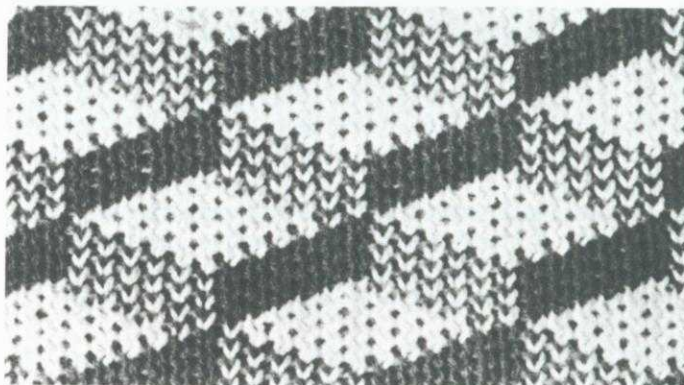



## JACQUARD

The following methods are only possible on a double bed machine and eliminate floating threads on purl side of knitting when doing two-colour work. These methods can only be used with fine to medium yarns.

#### METHOD 1 (IV)





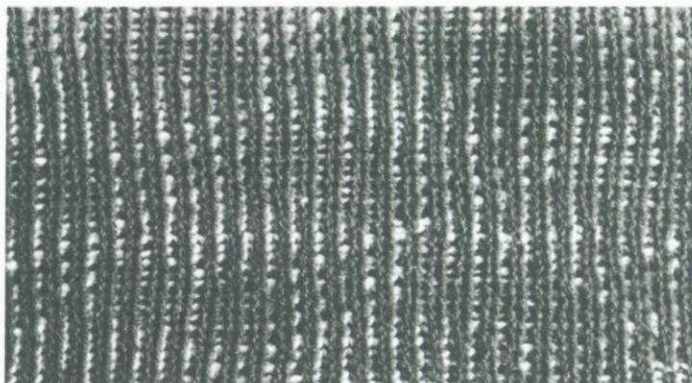
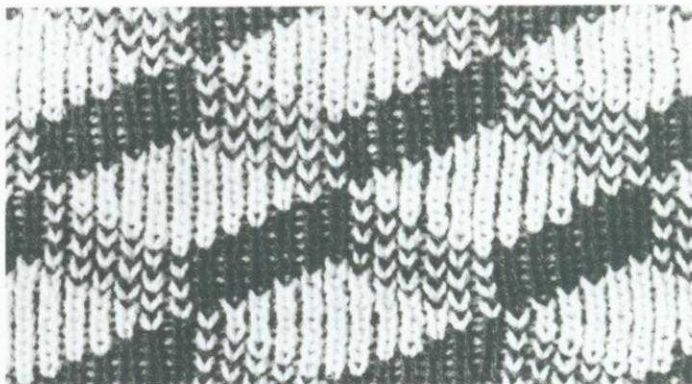

- Choose thickness of yarn as advised on illustrated pattern charts.
- Cast on to your choice. Before starting to knit your design, make sure there is an even number of needles on each needle bed.
- Carriages on right-hand side.
- Fit second yarn guide.
- Thread machine with second yarn and fix it to the right-hand clamp.
- Set back carriage with  key and Jacquard key  depressed simultaneously and needle return buttons in upper position .
- Set front carriage with key  (keys cancelled),  Jacquard key depressed and needle return buttons in neutral position .

- Needle selection buttons  on front carriage.
- Set stitch size on back carriage as for 1/1 rib.
- Set stitch size on front carriage as for 1/1 rib increased by 1/2 size.
- Space selector 5.
- Flow combs alternate.
- Front bed normal position.
- Connect power lead to the selection box.
- Switch on the selection box .
- Insert either a geometric or a decorative programme-card showing the design of your choice (see page 22 and 27).
- Position cursor and cursor stops (see page 10).
- Set your design (see page 15 "Setting of a design").
- Push cursor against right-hand stop.
- Set figure on decorative design adjustment dial opposite to reference mark.
- Set the switches of the selection box as indicated on the illustrated pattern charts according to design.
- Position starting line of your design opposite to pattern-line indicator visible through the programme-card cover.
- Actuate the automatic card advance switch by giving two upward  movements when using a geometric programme-card – or give one short downward  movement when using a decorative programme-card.
- Knit.
- When the pattern is finished, remove second yarn guide.

## METHOD 2 (V)



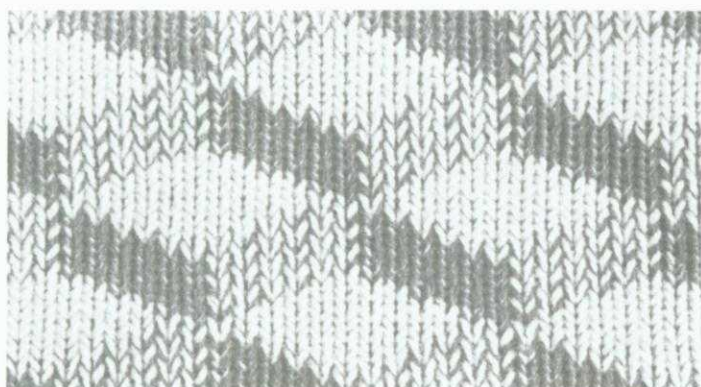
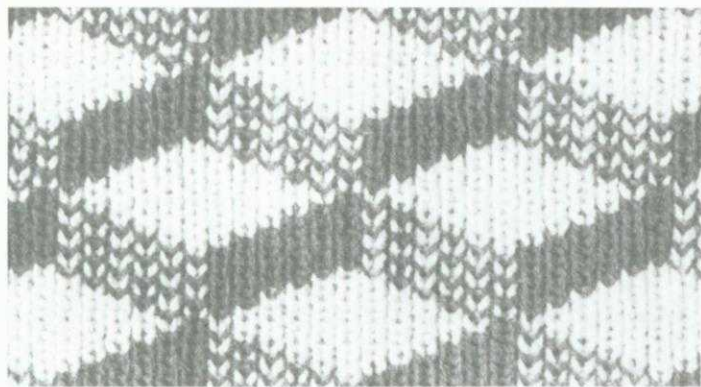

- Set back carriage as explained in method 1.
- Set front carriage as follows:  
Depress simultaneously key  and Jacquard key .
- Needle selection buttons .
- Needle return buttons in neutral position .
- Stitch size as for 1/1 rib increased by 1 or 2 sizes.

### METHOD 3 (VI)



Set back carriage as explained in method 1.

Set front carriage as follows:

- Depress key .
- Needle selection buttons .
- Needle return buttons in neutral position .
- Stitch size as for 1/1 rib increased by 2 sizes.
- The stitch size on the back carriage must be half the front carriage stitch size.

#### IMPORTANT:

1. When using the second yarn guide, do not bring needles into holding position 3, they would be automatically recalled by the Jacquard key.
2. Should you leave your knitting, stop carriages on right-hand side. For any other advice, refer to hint No. 4 or 5, page 33, according to design.

#### NOTE:

You can also set the automatic row advance stop/every other needle selector switch in upper position  in order to obtain an automatic selection of every other needle in all white sections of the programme-card.



## SINGLE DESIGN IN JACQUARD

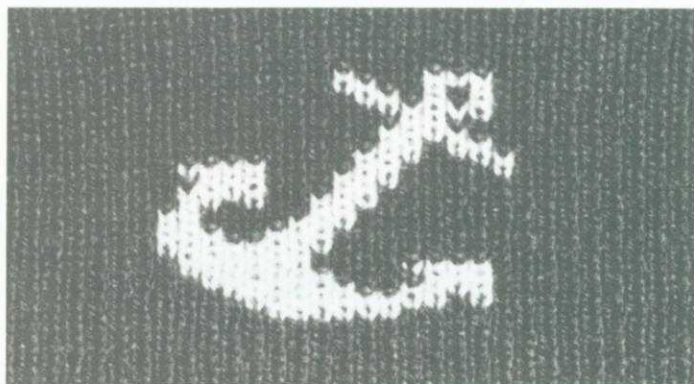

This method is only possible on a double bed machine and eliminates floating threads on purl side of knitting when doing two-colour work. It can only be used with fine to medium yarns.

- Choose thickness of yarn as advised on illustrated pattern charts.
- Cast on to your choice. Before starting to knit your design, make sure there is an even number of needles on each needle bed.
- Carriages on right-hand side.
- Fit second yarn guide.
- Thread machine with second yarn.
- Set back carriage with key  and Jacquard key  depressed simultaneously and needle return buttons in upper position .
- Set front carriage with key , needle selections buttons and needle return buttons in neutral position .
- Set stitch size on back carriage as for 1/1 rib.
- Set stitch size on front carriage as for 1/1 rib increased by 2 sizes.
- Space selector 5.
- Flow combs alternate.
- Front bed normal position.
- Connect power lead to the selection box.
- Switch on the selection box .
- Insert either a geometric or a decorative programme-card showing the design of your choice (see page 22 and 27).
- Position cursor and cursor stops (see page 10).



- Set your design (see page 15, "Setting of a design").
- Push cursor against right-hand stop.
- Set figure on decorative design adjustment dial opposite to reference mark.
- Set the switches of the selection box as indicated on the illustrated pattern charts according to design.
- Position starting line of your design opposite to pattern-line indicator visible through the programme-card cover.
- Actuate the automatic card advance switch by giving two short upward ↑ movements when using a geometric programme-card – or give one short downward ↓ movement when using a decorative programme-card.
- Knit.
- When the pattern is finished, remove second yarn guide.

**IMPORTANT:**

1. When using the second yarn guide, do not bring needles into holding position 3, they would be automatically recalled by the Jacquard key.
2. Should you leave your knitting, stop carriages on right-hand side. For any other advice, refer to hint No. 4 or 5, page 33, according to design.

**NOTE:**

You can also set the automatic row advance stop/every other needle selector switch in upper position  in order to obtain an automatic selection of every other needle in all white sections of the programme-card.



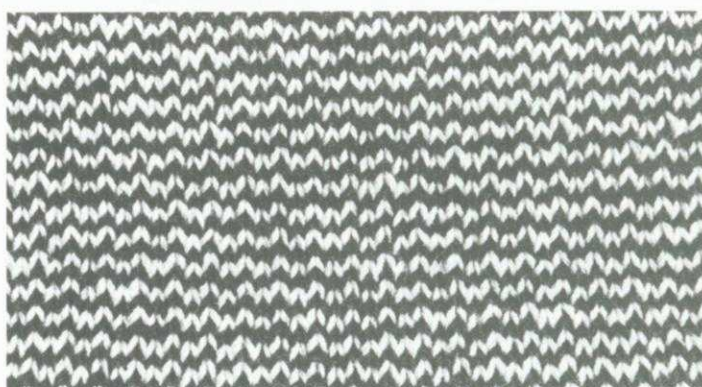

## NORWEGIAN JACQUARD (VII)



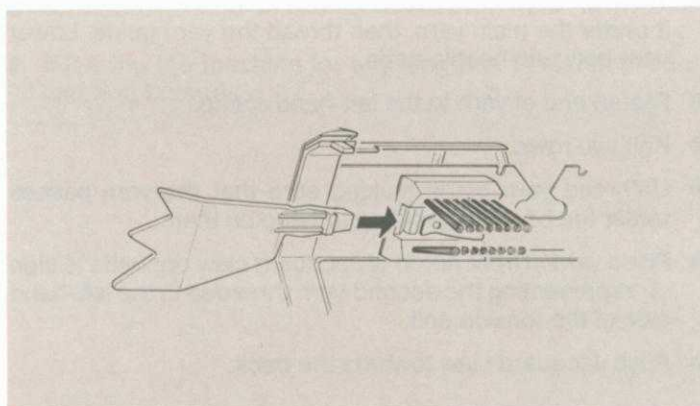

This method is only possible on a double bed machine and eliminates floating threads on purl side of knitting when doing two-colour work. It is only used with fine to medium yarns.

- Choose thickness of yarn as advised on illustrated pattern charts.
- Select an even number of needles on each needle bed.
- Cast-on in close rib and knit the number of rows required before starting to knit Jacquard.
- Begin design with carriages on right-hand side.
- Insert Jacquard claw at the left-hand side of the back carriage, signs „|° and boss on top of claw, into the fixing spring located between left-hand, brush of carriage. Insertion is made easier by unlocking and lifting the carriage. Do not forget to lock it again.



- Keys cancelled  on both carriages.
- Needle selection buttons .
- Needle return buttons in neutral position  on both carriages.
- Stitch size as for 1/1 Rib increased by one or two sizes on both carriages.
- Space selector 4 or 5.
- Flow combs alternate.
- Front bed normal position.
- Connect power lead to the selection box.
- Switch on the selection box .
- Insert either a geometric or a decorative programme-card showing the design of your choice (see page 22 and 27).
- Position cursor and cursor stops (see page 10).
- Centralise your design (see page 15, "Setting of a design").
- Push cursor against right-hand stop.
- Set figure on decorative design adjustment dial opposite to reference mark.

To work out this figure, only count the number of stitches and rows **visible** in 10 cm on your test sample.

- Switch off the selection box .
- Set all switches of the selection box in neutral position.
- Switch on the selection box .
- Set reverser in upper position .
- Position starting line of your design opposite to pattern-line indicator visible through the programme-card cover.
- Actuate the automatic card advance switch by giving two short upward  movements when using a geometric programme-card give one short downward  movement when using a decorative programme-card.
- Set row repeat switch in upper position .
- Knit one row in main yarn, the carriages are now on left-hand side.
- Unthread yarn guide making sure that the yarn passes under the brushes avoiding to hang on them.
- Place yarn in back notch of Jacquard claw opposite to sign |° representing the main yarn threaded in the right-hand side of the tension unit.
- Push Jacquard claw towards the front.
- Thread left-hand side of tension unit with second yarn pass it **under** the main yarn, then thread the yarn guide. Lower yarn between needle beds.
- Fasten end of yarn to the left-hand clamp.
- Knit two rows.
- \* ● Unthread yarn guide making sure that the yarn passes under the brushes avoiding to hang on them.
- Place yarn in front notch of Jacquard claw opposite to sign °| representing the second yarn threaded in the left-hand side of the tension unit.
- Push Jacquard claw towards the back.

- Unhook main yarn, pull it towards the front and present it in the opening of the carriage, above the yarn guide (the yarn passes in front of the right-hand brush). When moving the carriages to the right-hand side, tend the yarn backwards and to the left-hand side. It will thread into the yarn guide automatically.

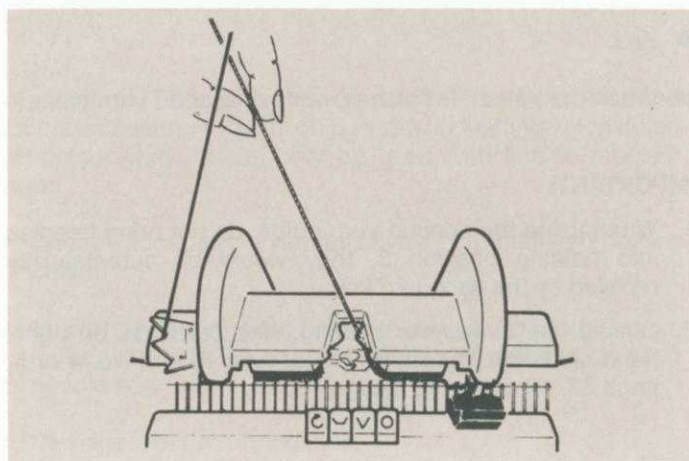

- Knit two rows.
- Unthread yarn guide making sure that the yarn passes under the brushes avoiding to hang on them.
- Place yarn in back notch of Jacquard claw opposite to sign |°.
- Push Jacquard claw towards the front.
- Unhook second yarn, pull it towards the front etc. ... (see above).
- Knit two rows\*.
- Repeat from \* to\*.

#### IMPORTANT:

Should you leave your knitting, stop carriages on right-hand side, main yarn threaded in yarn guide.

For any other advice, refer to hint No. 4 or 5, page 33, according to design.

When you resume knitting, reset the switches on selection box as explained above.

#### NOTE:

You can also set the automatic row advance stop/every other needle selector switch in upper position in order to obtain an automatic selection of every other needle in all white sections of the programme-card.



## WEAVING EFFECT (VII)

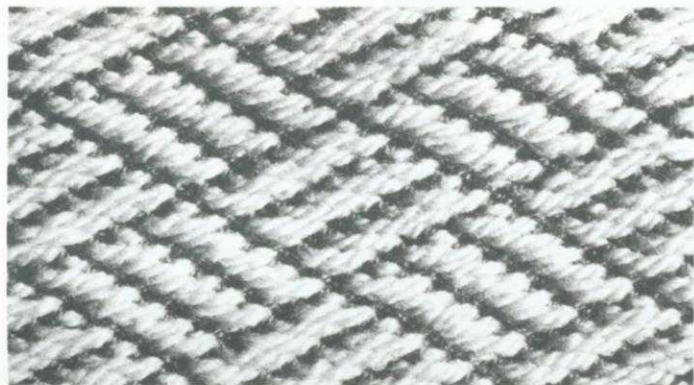

A weaving effect is obtained by using a generally thicker, differently coloured second yarn.

- Choose thickness of yarn as advised on illustrated pattern-charts.
- Cast-on to your choice. Before starting to knit your design, transfer all the stitches from the front bed onto the back bed needles.
- Carriage on right-hand side.
- Lift carriage to insert weaving brushes. Make sure the round brushes face you and that the carriage is fully replaced on the upper slide rail.

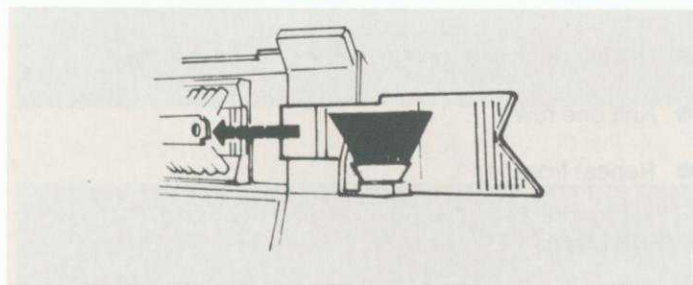

- Thread the thicker yarn into the left-hand side of tension unit, but do not thread carriage yarn guide.
- Fasten the end of the yarn on the clamp found on the same side as the carriage. The thicker yarn must always be ahead of the main yarn when knitting. The weaving brush guides hold the yarn in position as the carriage is passed from one side to the other.

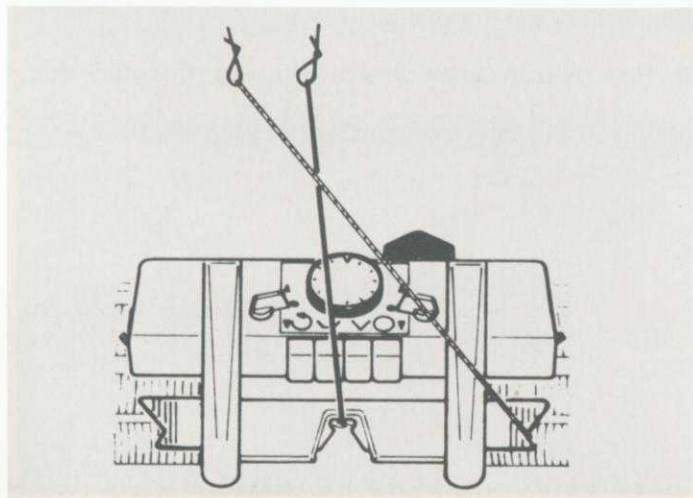

- Key  $\square \wedge$ .
- Needle return buttons in neutral position.
- Stocking stitch size.
- Space selector 6.
- Flow combs opposite.
- Front bed upper position.
- Connect power lead to the selection box.
- Switch on the selection box  $\square$ .
- Insert a geometric programme-card showing the design of your choice (see page 22).
- Position cursor and cursor stops (see page 10).
- Centralise your design (see page 15, „Setting of a design“).
- Push cursor against right-hand stop.
- Set the switches of the selection box as indicated on the illustrated pattern charts according to design.
- Position starting line of your design opposite to pattern-line indicator visible through the programme-card cover.
- Actuate the automatic card advance switch by giving two short upward  $\uparrow$  movements.
- On carriage side, move the 2nd needle in working position 2 in order to obtain nice edges whatever design is knitted.
- Knit one row.
- For quicker operation, as the thick yarn reaches the last needle to be knitted remove it from the weaving brush guide.

If you have forgotten to remove the yarn:

- Lower the front bed and pull the yarn towards you.
- Replace front bed in upper position.

On single bed machine pull the yarn behind and under the knitting retainer.

- Continue knitting until design is finished.
- When the knitting is finished, remove the weaving brushes.
- If leaving the machine for any length of time, remove the weaving brushes.

#### NOTE:

Choose the thickness of the weaving yarn according to the design. If you wish to knit another design as the ones proposed on the illustrated pattern charts for weaving effect, take care to use a thinner weaving yarn if 4 or 5 following black squares are programmed on the card.

#### IMPORTANT:

Should you leave your knitting, stop carriage on right-hand side. For any other advice, refer to hint No. 4, page 33.

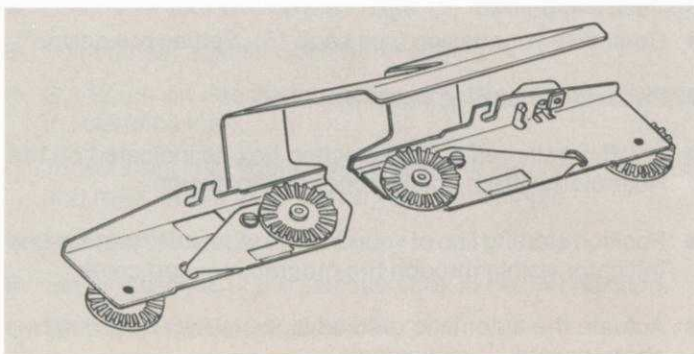

#### NOTE FOR SINGLE BED:

- After casting on knit 4 or 5 rows slightly pulling on the mounting comb.
- Before attaching the knitting retainer:
- Fit both central wheels, raised side in front of you, into the corresponding slots and push backwards.
- A better result can be obtained when using weights.

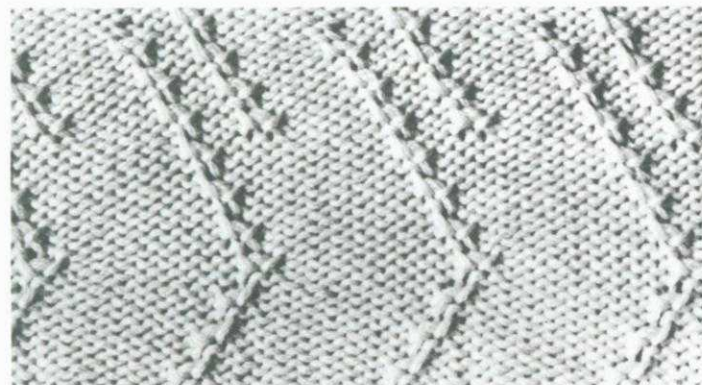

## PATTERNS WITH NEEDLES IN HOLDING POSITION (IX)



- Choose thickness of yarn as advised on illustrated pattern charts.
- Cast-on to your choice. Before starting to knit your design, transfer all the stitches from the front bed onto the back bed needles.
- Carriage on right-hand side.
- Key .
- Needle return buttons in upper position .
- Stocking stitch size.

- Space selector 5.

- Flow combs opposite.

- Front bed upper position.

- Connect power lead to the selection box.

- Switch on the selection box .

- Insert a geometric programme-card showing the design of your choice (see page 22).

- Position cursor and cursor stops (see page 10).

- Centralise your design (see page 15, "Setting of a design").

- Push cursor against right-hand stop.

- Set the switches of the selection box as indicated on the illustrated pattern charts according to design.

- Position starting line of your design opposite to pattern-line indicator visible through the programme-card cover.

- Actuate the automatic card advance switch by giving two short upward  movements.

- Knit one row.

- \*● Needle return buttons in lower position .

- Knit one row.

- Needle return buttons in upper position .

- Knit one row\*

- Repeat from \* to \*.

#### IMPORTANT:

Should you leave your knitting, stop carriage on right-hand side. For any other advice, refer to hint No. 4, page 33.

#### NOTE FOR SINGLE BED:

- After casting on knit 4 or 5 rows slightly pulling on the mounting comb.

Before attaching the knitting retainer:

- Remove both central wheels by pushing them forwards.

A better result can be obtained when using weights.



## GARTER STITCHES (X) AND LACE STITCHES (XI)

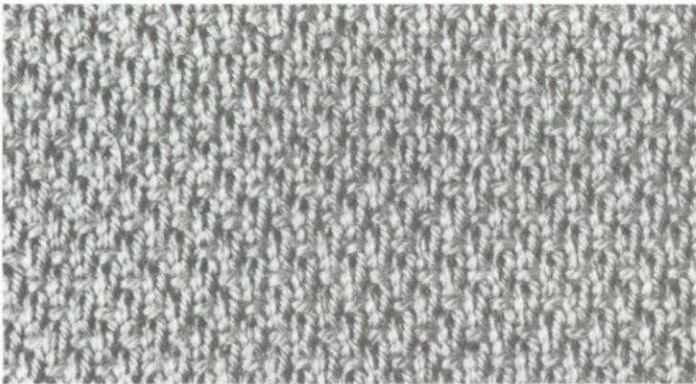
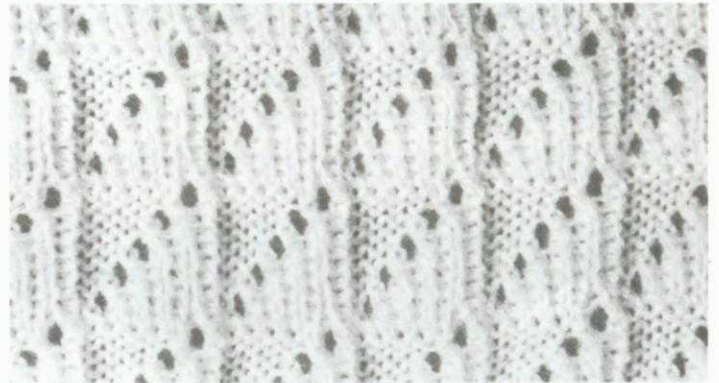
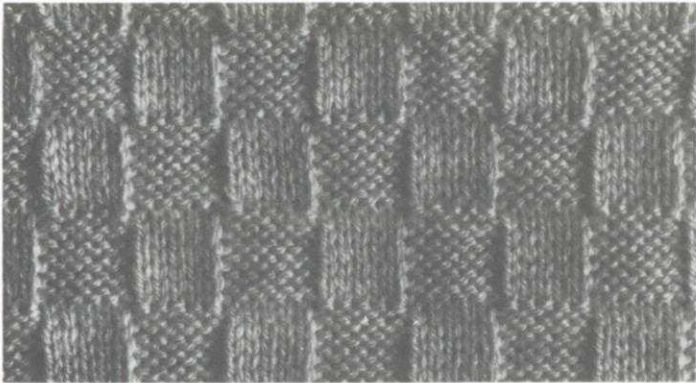
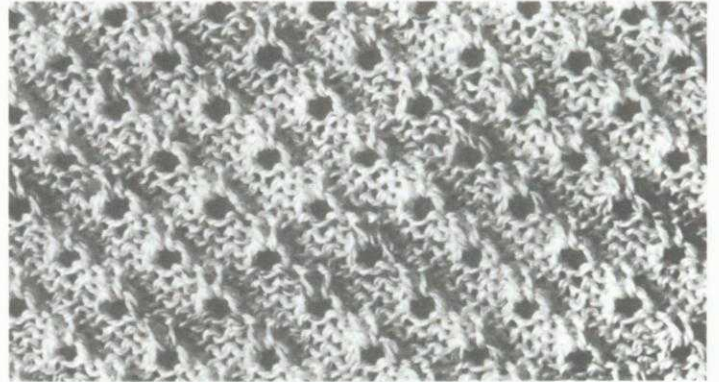
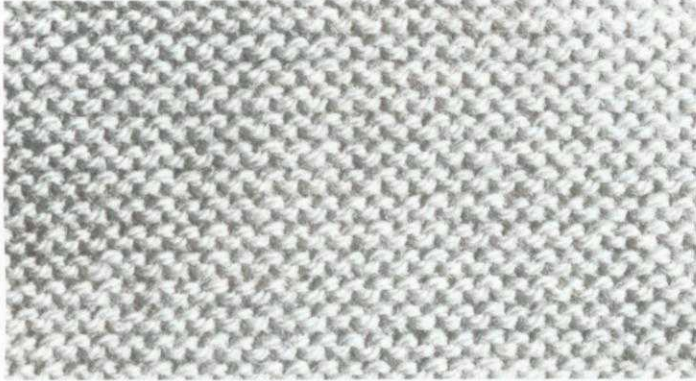

To knit these designs, you must be in possession of the double garter stitch carriage.

The instructions "how to use it" are given in the booklet delivered with this accessory.

You can also buy some programme-cards at your retailer.



# XIII. WHAT TO DO IF . . .

## THE CARRIAGE JAMS WITH ROW REPEAT SWITCH IN NEUTRAL POSITION

- Note pattern line on which you have stopped your knitting as well as the direction of programme-card on indicator.
- If you use the Motor-Drive, disconnect the engaging bolt and press the speed control to move the drive slot along the rail.
- Switch off the Selection box ○.
- Loosen the cursor stop that has just been passed.
- Bring it against cursor and push it in the direction it was knitting until it is disconnected from the carriage.
- If the second yarn guide is fitted to the carriage, disengage needle raisers C covering the needles as illustrated (pull and turn them).

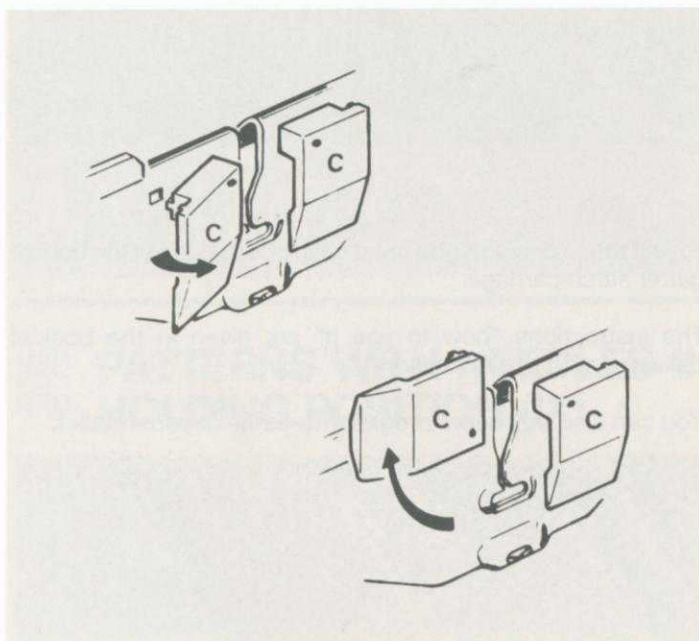

- Raise front of carriage and return it to starting point.
- Lock the carriage back on the rail.
- Unpick the part of the row to bring the yarn to the carriage side.
- Reset the row counter if necessary.
- Position the cursor stop and push the cursor against the stop on the same side as the carriage.
- Move all needles back to working position 1.
- Switch on the selection box |.
- Actuating the automatic card advance switch, reset programme-card on the previously noted pattern line.
- Actuate the automatic card advance switch by giving two short movements in the opposite card direction to the one stated previously and two short movements in the same direction as noted previously.
- Knit.

## THE CARRIAGE JAMS WITH ROW REPEAT SWITCH IN UPPER POSITION OR LOWER POSITION.

- Note pattern line on which you have stopped your knitting as well as the direction of programme-card on indicator: if you have followed the knitting instructions, programme-card will advance when carriages are on right-hand side.
- If you use the Motor-drive, disconnect the engaging bolt and press the speed control to move the drive slot along the rail.
- Switch off the selection box ○.
- Set row repeat switch in neutral position ○.
- Loosen the cursor stop which has just been passed.
- Bring it against the cursor and push it in the direction it was knitting until it is disconnected from the carriage.
- If the second yarn guide is fitted to the carriage disengage needle raisers C covering the needles as illustrated opposite (pull and turn them).
- Raise front of carriage and return it to starting point.
- Lock the carriage back on the rail.
- Unpick the part of the row and nearly one row to bring the yarns back to the right-hand side.
- Reset the row counter.
- Position the cursor stop and push cursor against the stop on the same side as the carriage.
- Move all needles back to working position 1.
- Switch on the selection box |.
- Set row repeat switch either in upper position □ or lower position ■ according to design.
- Actuating the automatic card advance switch, reset programme-card on the previously noted pattern-line.
- Actuate the automatic card advance switch by giving two short movements in the opposite card direction to the one stated previously and two short movements in the same direction as noted previously.
- Knit.

## YOU CANNOT CAST-ON:

- Check that the Jacquard keys have been cancelled.

## THE NEEDLES SELECTED FOR TWO-COLOUR WORK REMAIN IN HOLDING POSITION 3:

- Undo one row.
- Reset the needles in holding position 3 back into working position 1, using the single eyelet transfer tool.
- Replace the carriage on the same side as the yarn.
- Check that the Jacquard key is correctly depressed.
- Actuating the automatic card advance switch, make sure to reset programme-card on the correct pattern line as well as in the correct direction.

## THERE IS NO SELECTION:

Check if:

- Selection box is lit up.
- Cursor is on same side as carriage.
- Drive shaft is correctly fit.
- Programme-changer is not set in neutral position.
- Starting line of design is opposite to pattern-line indicator.
- Settings of carriage and selection box correspond to the instructions given on illustrated pattern charts.
- Cursor stops are correctly positioned (see page 10).

## THE PROGRAMME-CARD IS NOT MOVING:

Check if:

- Figure 0 on decorative design adjustment dial is set opposite to reference mark.

## THE PROGRAMME-CARD IS NOT MOVING ANYMORE:

Check if:

- Programme-card cover with card has been inserted straight into slot of selection box.

## STITCHES NEXT TO A SINGLE DESIGN ARE KNITTED IN SECOND COLOUR:

Check if:

- The cursor stops are correctly positioned (see page 10).
- The programme-card is adapted to knit a single design, i. e. use a programme-card showing four white squares on either side of the design at its widest part.

## THE EDGE STITCHES OF A SINGLE DESIGN KNIT BOTH YARNS:

Check if:

- The Cursor stops have not moved during knitting.
- The edge weights and claws are rehung every ten rows.

## A DECORATIVE DESIGN IS OUT OF SHAPE:

Check if:

- The figure set on decorative design adjustment dial corresponds to the test sample (see page 26).
- When knitting Norwegian Jacquard the number of rows visible on your sample has been multiplied by 2.
- Row repeat switch is set in neutral position, **except when knitting Norwegian Jacquard.**
- The weights you are using for your knitting are correctly balanced. (refer to Test sample page 26).

## A TUCK OR SLIP STITCH DESIGN IS NOT CORRECTLY KNITTED:

If one or several needles, carrying tuck stitches or which have not knitted for several rows, do not knit normally after a needle selection changing,

check if:

- The number of weights is not too important.
- The front bed is set in upper position.
- The flow combs are opposite.
- The cursor stops are correctly positioned (see page 10).
- The needles are not damaged.

## YOU HAVE TO UNDO ONE OR SEVERAL ROWS, FOLLOW THESE INSTRUCTIONS:

- 1 - Switch off the selection box  $\circ$ .
- 2 - Note pattern line opposite to pattern-line indicator (eg line 2).
- 3 - Note direction on indicator either  $\blacktriangle$  or  $\blacktriangledown$ .
- 4 - Remove carriage if necessary and bring it back to the right-hand side without knitting.
- 5 - Undo and count the edges (see following instructions) until the yarns are on the right-hand side on the same side as the carriage.
- 6 - Check the row counter rows.
- 7 - Deduct from the row counter the number of rows taken back.
- 8 - Switch on the selection box  $\blacksquare$ .
- 9 - Referring to the above mentioned edges, bring programme-card to the correct pattern-line and correct card direction either  $\blacktriangle$  or  $\blacktriangledown$  (see later instructions).
- 10- Resume knitting.

## HOW TO COUNT THE EDGES ACCORDING TO SELECTION BOX SETTINGS:

### THREE CASES ARE POSSIBLE ACCORDING TO THE SETTING OF THE ROW REPEAT SWITCH:

- 1 - **Row repeat switch in neutral position  $\blacksquare$**   
Starting edge and following edges reached when undoing have to be counted. Note this number.
- 2 - **Row repeat switch in lower position  $\blacksquare$ :**  
Each right-hand edge of knitting including the starting edge if it is on the right-hand side and only on the right-hand side have to be counted as an edge. Note this number.
- 3 - **Row repeat switch in upper position  $\square$ :**  
Each right-hand edge of knitting including the starting edge reached by the main yarn have to be counted as an edge. When you have finished undoing, the main yarn must be on the right-hand side and the second yarn must be on the left-hand side. Note this number.

## How to reset your programme-card to resume knitting: Two cases are possible with geometric programme-card:

- 1 - **The design is read in the same direction: rapid return of programme-card.** Symbol  $\text{f}$  on illustrated pattern charts.

Write down the complete numbering of the pattern lines of your design. You will find it on the right-hand side of your programme-card.

Example: design x Card X.

4  
3 during knitting you perform in sequence  
2 these pattern lines in this order.  
1

In any case line No. 1 is knitted with card indicator  $\blacktriangle$ , lines 2, 3, 4 etc. increasing numbers with card indicator  $\blacktriangledown$ .

Put these symbols opposite to the numbers



Circle the line number on which you have stopped.

Example 3  $\blacktriangledown$

Starting from this number as first edge and proceeding from the top to the bottom, in this example when you arrive at line No. 1, start to count from line No. 4 to arrive at the number of edges you have previously counted.

EXAMPLE: 6 edges = knitting stopped on line No. 3  $\blacktriangledown$



You will have to resume knitting with pattern line No. 2 aligned with pattern-line indicator and card indicator  $\blacktriangledown$  (noted opposite to number).

To position card opposite to correct pattern line and after having set all switches of the selection box in the correct position, set programme-card opposite to line No. 1. Give the necessary short movements using the automatic card advance switch to bring the correct pattern line (in this example line No. 2). in the correct direction (in this example  $\blacktriangledown$ ) opposite to pattern-line indicator.



2 - The design is read continuously in both directions.

Symbol  on illustrated pattern charts.

Write down the complete numbering of the pattern lines of your design. You will find it on the right-hand side of your programme-card.

EXAMPLE: design x Card X

4  
3  
2  
1

Complete this numbering with the number in the reverse direction until line No. 2.

EXAMPLE:

2  
3  
4 during knitting you perform in sequence  
3 these pattern lines in this order.  
2  
1

In any case line No. 1 is knitted with card indicator ▲, lines 2, 3, 4 etc. increasing numbers with card indicator ▼, lines . . . 3, 2 decreasing numbers with card indicator ▲.

Put these symbols opposite to the numbers.

EXAMPLE:

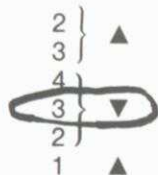

Circle the line number on which you have stopped, being careful to have taken the correct card direction either ▲ or ▼ having previously noted (eg. 3 ▼). Also make sure to note the correct number against the correct direction. Failure to do this would give incorrect result.

Starting from this number as first edge and proceeding from the top to the bottom (in this example when you arrive at line No. 1, start to count from line No. 2 which is **on top** to arrive at the number of edges you have previously counted.

EXAMPLE: 6 edges = knitting stopped on line No. 3 ▼.



You will have to resume knitting with pattern line No. 4 aligned with pattern-line indicator and card indicator ▼.

To position card opposite to correct pattern line and after having set all switches of the selection box in the correct position, set programme-card opposite to line No. 1, give the necessary short movements using the automatic card advance switch to bring the correct pattern line (in this example line No. 4) in the correct direction (in this example ▼) opposite to pattern-line indicator.

# INDEX

	Page		Page
Accessories .....	32	(Setting of) .....	32
Calculation of figure for decorative design adjustment dial		(Use without programme-card) .....	19
with decorative programme-card .....	26	(Use with programme-card) .....	20-24
Carriages .....	32	Setting of a design .....	15-17
(Settings of) .....	32	Setting up the selection box .....	8
Chart with figures for decorative design		Settings of carriages .....	32
adjustment dial .....	28-29	Settings of selection box .....	32
Controls .....	11	Single design in Fair Isle .....	37-38
(Use of the different) .....	11-14	Single design in Jacquard .....	40-41
Cursor and cursor stops .....	7	Slip stitch knitting .....	35-36
Cursor position according to type of knitting .....	10	Some hints .....	33-34
Decorative programme-card .....	24	Test sample for decorative design .....	26
(Description of) .....	24-25	Tuck knitting .....	35
(Description of programme-card cover) .....	25	Use of the different controls .....	11-14
(Use of) .....	27-30	Use of the selection box with decorative	
(Test sample for) .....	26	programme-card .....	27-30
(Setting of a design with) .....	17	Use of the selection box with geometric	
Description of decorative programme-card .....	24-25	programme-card .....	22-23
Description of geometric programme-card .....	20-21	Use of the selection box without programme-card .....	19
Description of programme-card cover .....	21, 25	Weaving effect .....	43-44
Description of programme-card guide .....	23	What to do if .....	46-49
Description of selection box .....	4		
Fair Isle .....	36-37		
Garter stitches .....	45		
Geometric programme-card .....	20		
(Description of) .....	20-21		
Description of programme-card cover) .....	21		
(Setting of a design with) .....	15-16		
(Use of) .....	22-23		
Guide for programme-card .....	6		
(Description of) .....	23		
Hints .....	33-34		
(before, during, after knitting) .....	33-34		
How to knit .....	35-45		
Illustrated pattern chart .....	31-32		
Jacquard .....	38-40		
Knitting .....	35		
(Fair Isle) .....	36-37		
(Garter and lace stitches) .....	45		
(Jacquard, 3 methods of) .....	38-40		
(Norwegian Jacquard) .....	41-42		
(Patterns with needles in holding position) .....	44		
(Single design in Fair Isle) .....	37-38		
(Single design in Jacquard) .....	40-41		
(Slip stitch knitting) .....	35-36		
(Tuck knitting) .....	35		
(Weaving effect) .....	43-44		
Main parts of selection box .....	4-6		
Lace patterns .....	45		
Needles in holding position			
(Patterns with) .....	44		
Norwegian Jacquard .....	41-42		
Programme-card cover .....	21, 25		
(Description of) .....	21, 25		
Selection box .....	4		
(Description of) .....	4		
(Setting up of) .....	8		



