

INSTRUCTION MANUAL

CONTENTS

SECTION 1 - YOUR MACHINE

	PAGE
The Main Parts	1
The Accessories	2
How to set up your machine	3-5
How stitches are formed	7
How to use the carriage	8

SECTION 2 - LETS MAKE A JUMPER

	PAGE	PAGE	
The Back: How to cast on	9-10	The Front: How to shape a neck	14-15
How to make the rib	11-12	Decreasing	16
Stocking stitch	12	The Sleeves: How to increase	16
Casting off	13	The Neck Band:	16

SECTION 3 - FOR A MORE PROFESSIONAL TOUCH

	PAGE	PAGE	
How to get the right stitch size	17	Alternative ribs	20-22
Fully fashioned increases	18	Chain casting on	23-24
Fully fashioned decreases	19	Buttonholes	24
Decreasing several stitches	19		

SECTION 4 - FANCY STITCHES

	PAGE	PAGE	
Tuck stitches	25	Picture knitting	27
Lace stitches	25	Fair Isle	28
Slip stitches	26	Weaving	29
Pulled up stitches	26		

SECTION 5 - HELP! WHAT TO DO IF:

	PAGE	PAGE	
A stitch is dropped	30	The carriage jams	32
A stitch drops several rows	30	Caring for the machine	32
Undoing rows	31	Alphabetical index	33
Changing a needle	32		

DESCRIPTION - MAIN PARTS

The Machine

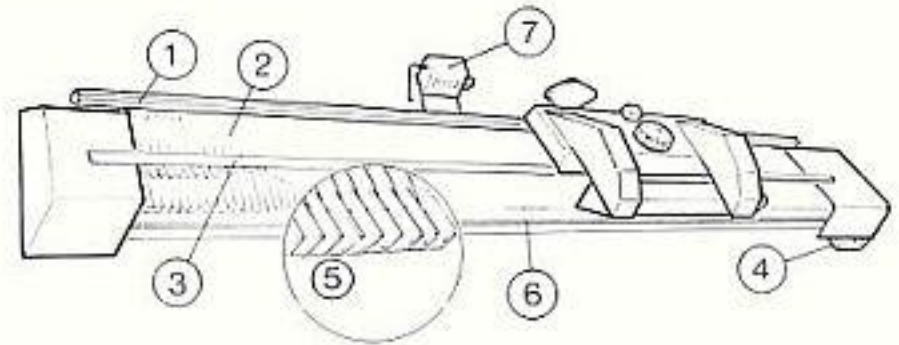

1. Slide rail
2. Needle bed
3. Graduated scale

4. Clamp socket
5. Flow combs
6. Support for cast-on combs
7. Row counter

The Carriage

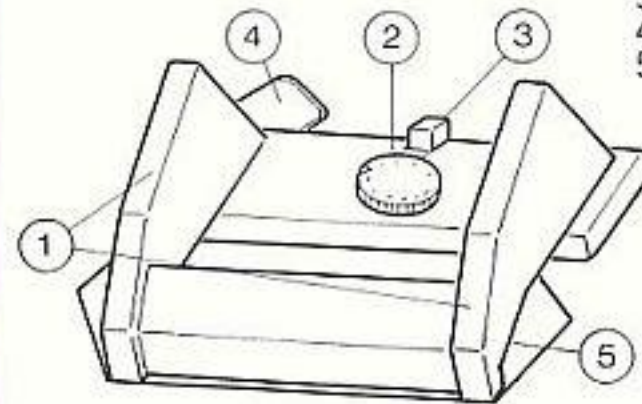

1. Handles
2. Stitch size dial
3. Needle selector switch
4. Row counter cam
5. Knitting retainer

ACCESSORIES

The accessories pictured are provided with your machine. Additional items can be purchased from your local Singer stockist.

Table clamps

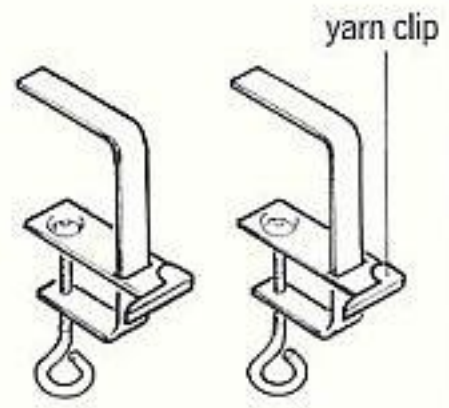

Edge weights

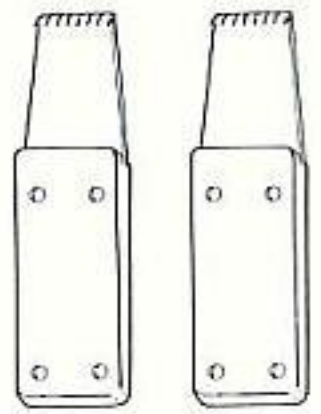

Needle

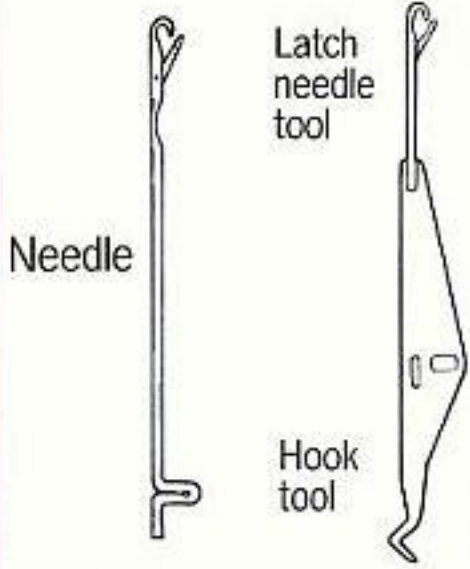

Row counter



1 and 2 eyelet tool

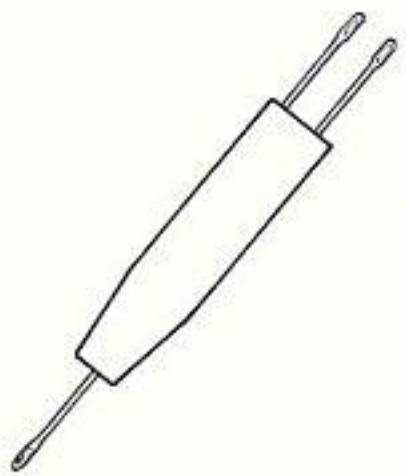

Cast on comb cover

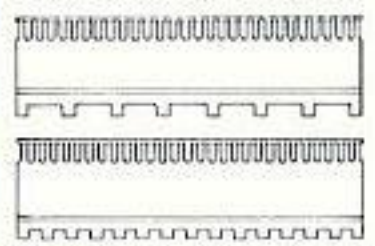

Combs + Needle selector tool 1/2 and 1/4

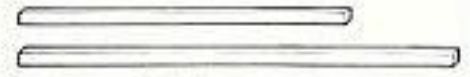

Bar weights

HOW TO SET UP YOUR MACHINE

SETTING UP THE ROW COUNTER

- 1 Place your machine upside down, needle bed and carriage laying on the table. Unscrew the two buttons on the rail until they come off the screws.
- 2 Place the two holes in the row counter holder on top of the screws. Slide the row counter to the middle of the machine, replace the buttons and tighten them securely.
- 3 Turn the machine the right way up and move it to the edge of the table.

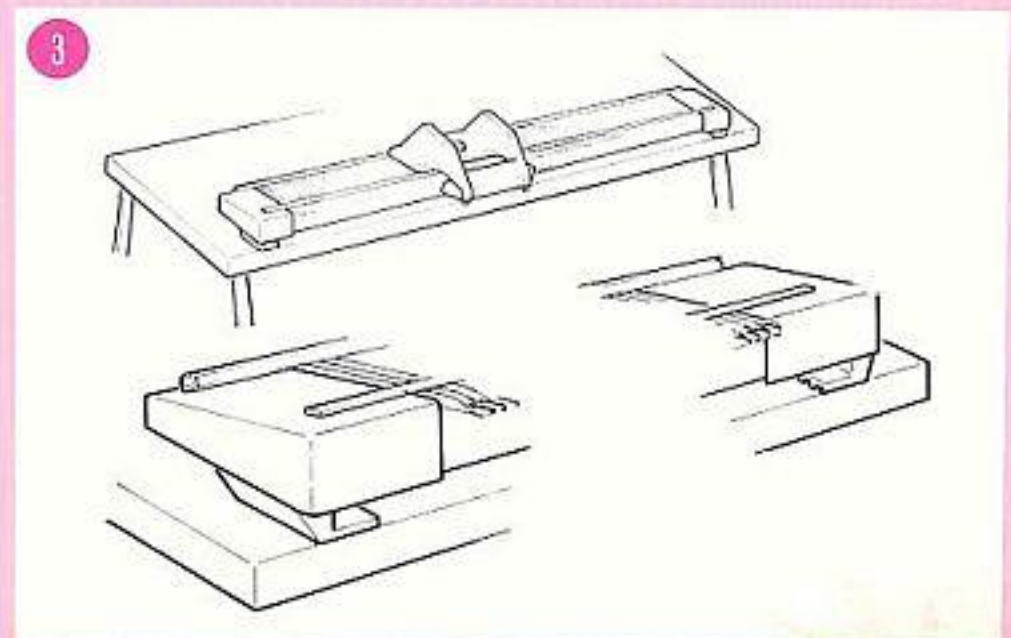
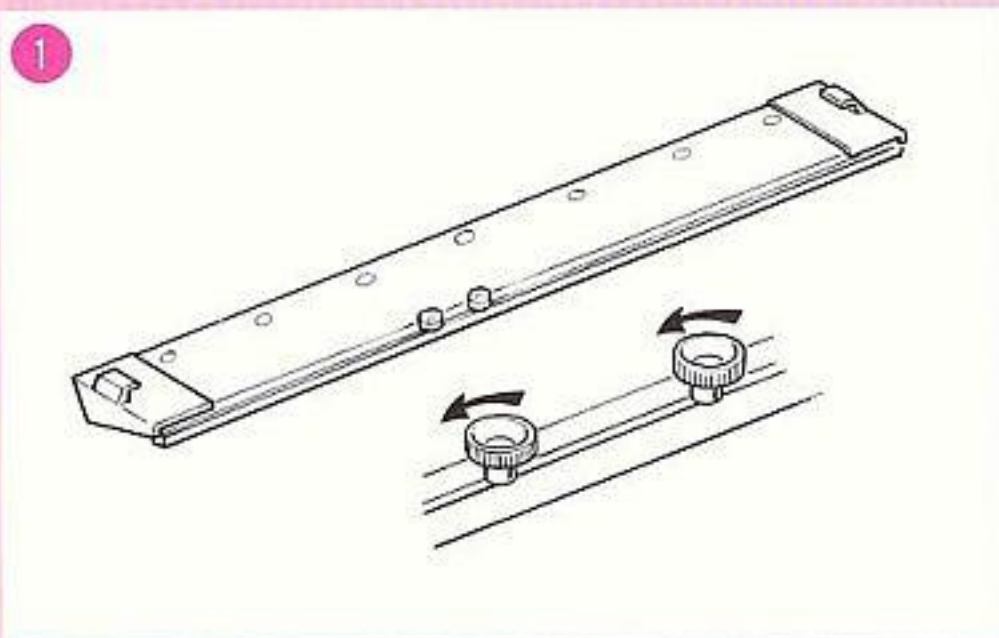
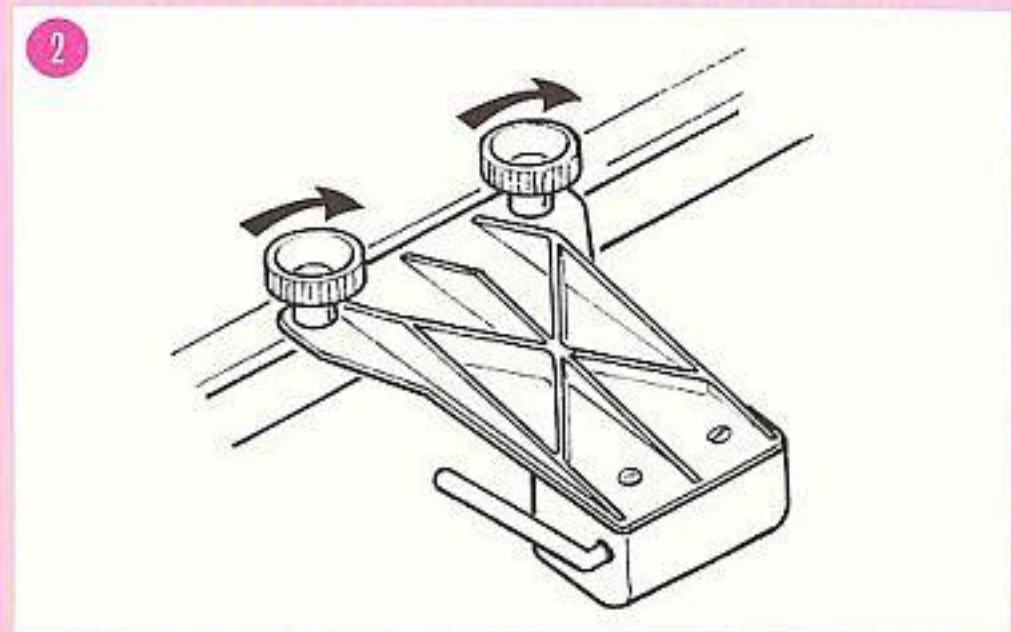

4 Use the table clamps to fasten the machine to the table. Lay the upper part of the table clamp onto the socket used to fasten the machine to the table. The movable plate passes under the table top. Tighten the screws so the machine is firmly attached to the table.

5 The carriage slides along a guide rail. It can be removed from either side of the machine by sliding it out of the guide rail.

6 To replace the carriage, slide it into the lower guide rail. The knitting retainer must be under the flow combs.

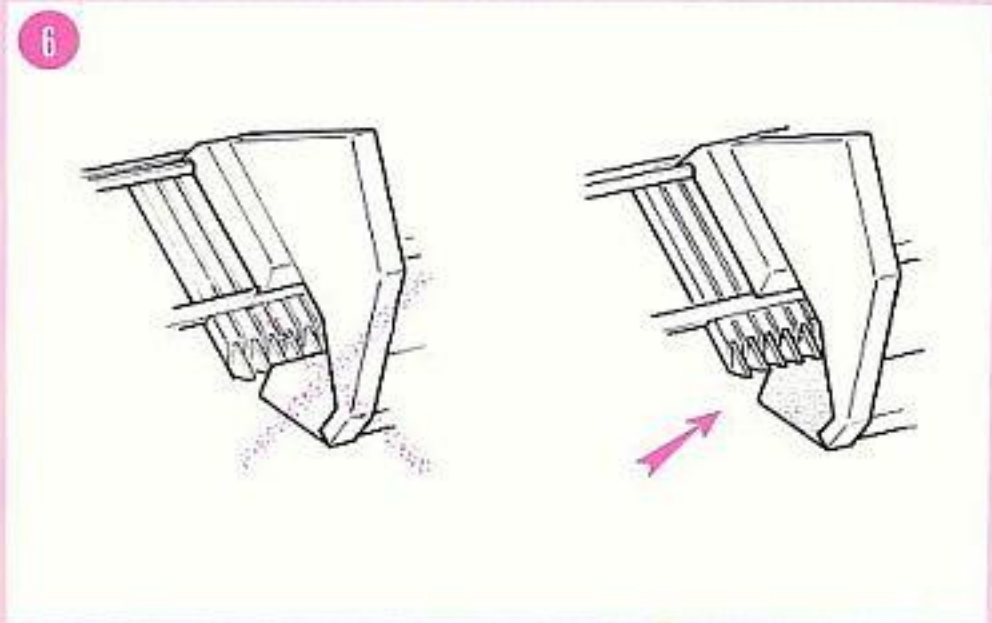
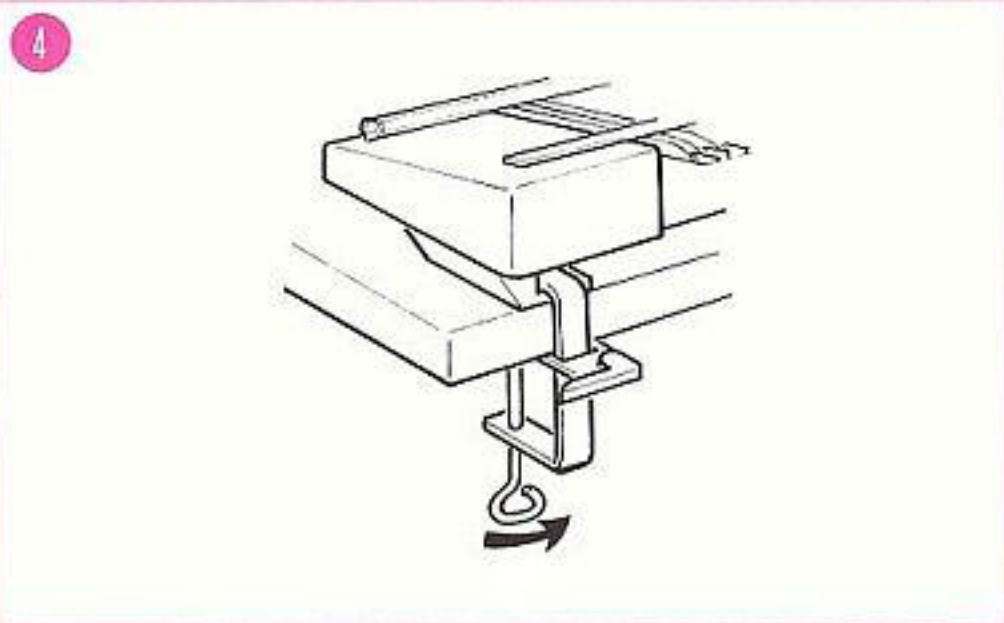
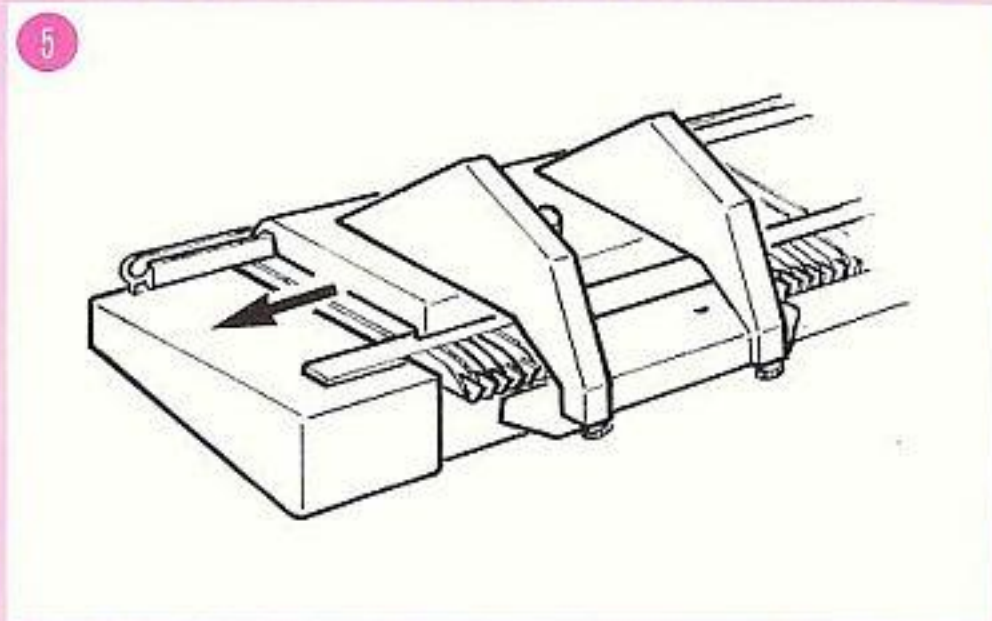

7 Remove carriage from the machine. Clip row counter cam into the slot at the back of the carriage. Replace carriage.

8 Slide carriage to row counter bracket. Move row counter lever down or up so that it is placed on row counter cam as pictured. Move the carriage backwards and forwards, making sure the numbers change each time the row counter cam passes the lever.

9 To reset the row counter to 0 push in on the knob and turn it towards the front of the machine.
To add turn the knob towards the front.
To subtract turn the knob towards the back.

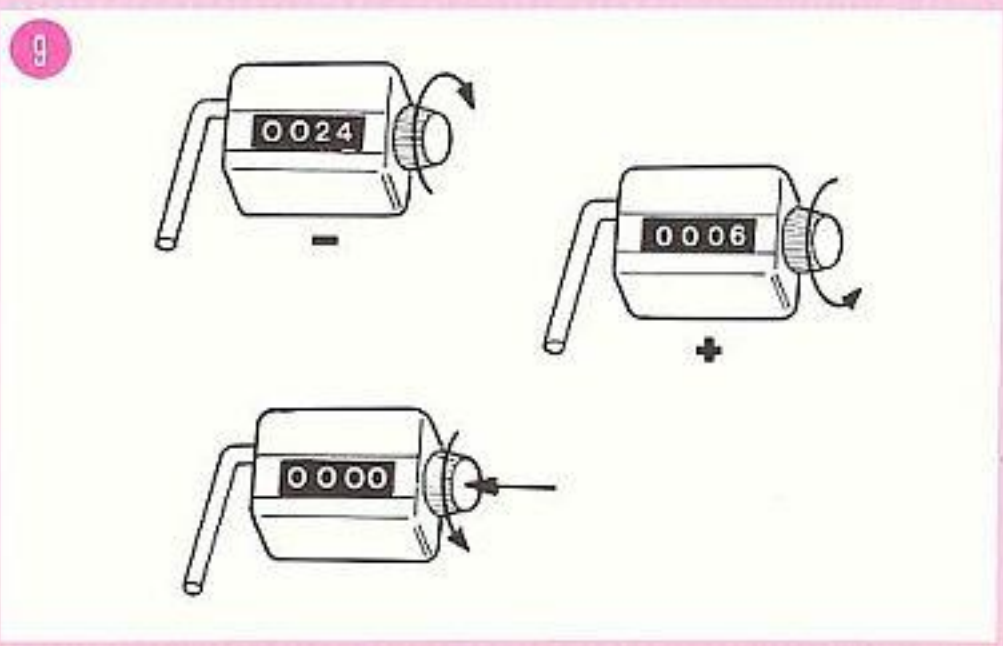
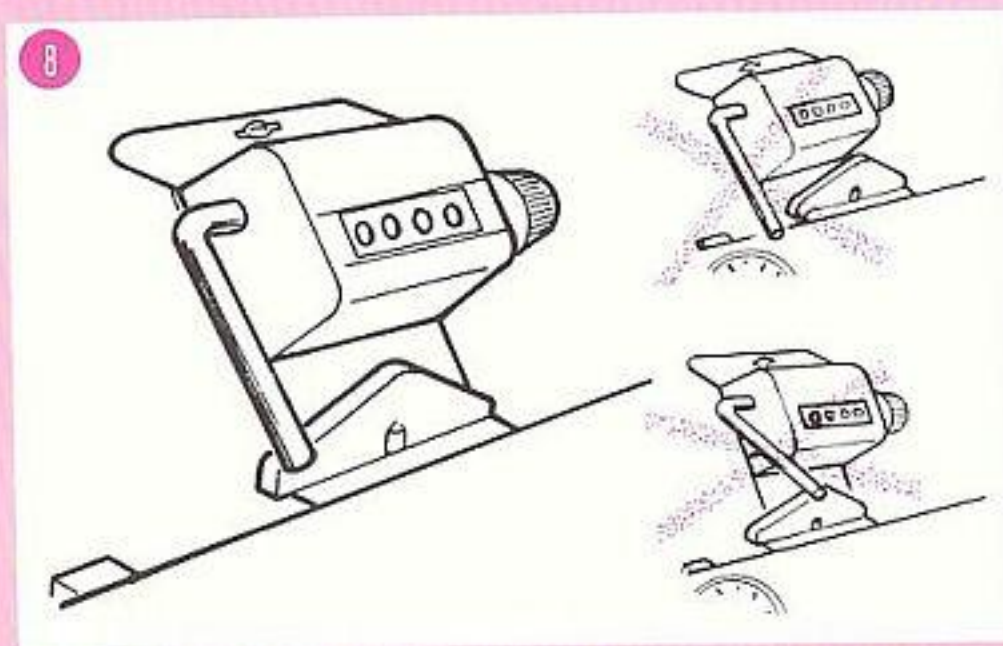

10 Every needle is numbered so you can quickly count how many stitches you are working with. Always start your knitting by selecting needles each side of 0, found in the centre of the needle bed.

11 Each needle sits in its own groove. There are 115 needles on the machine.

12 The needles will slide up and down in the grooves. There are 4 positions for the needles.

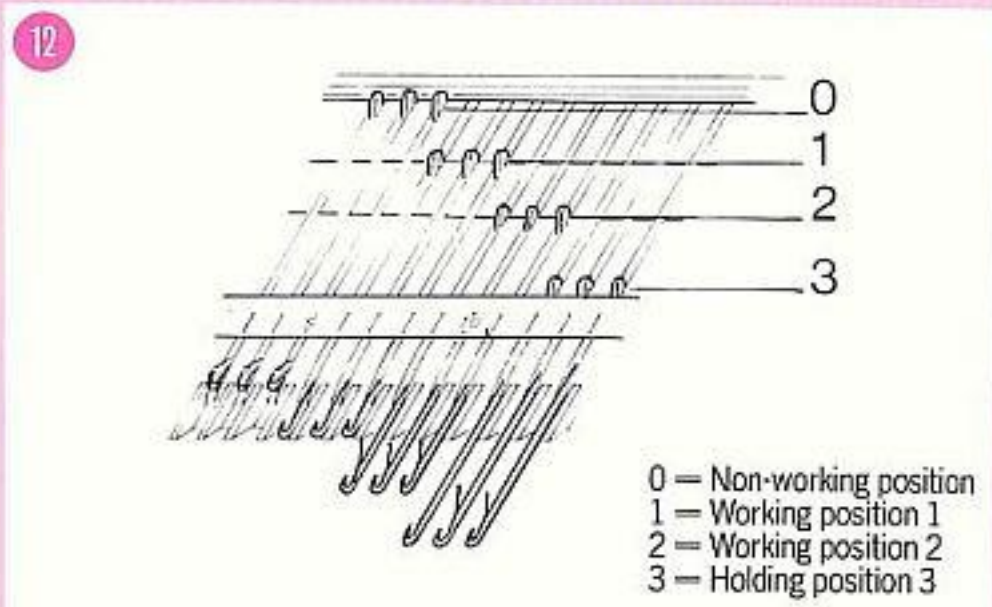
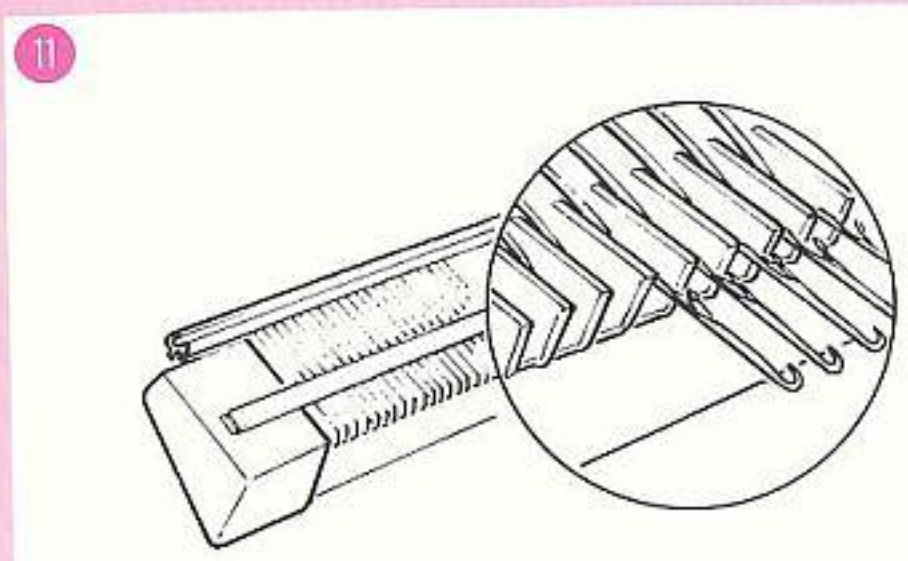
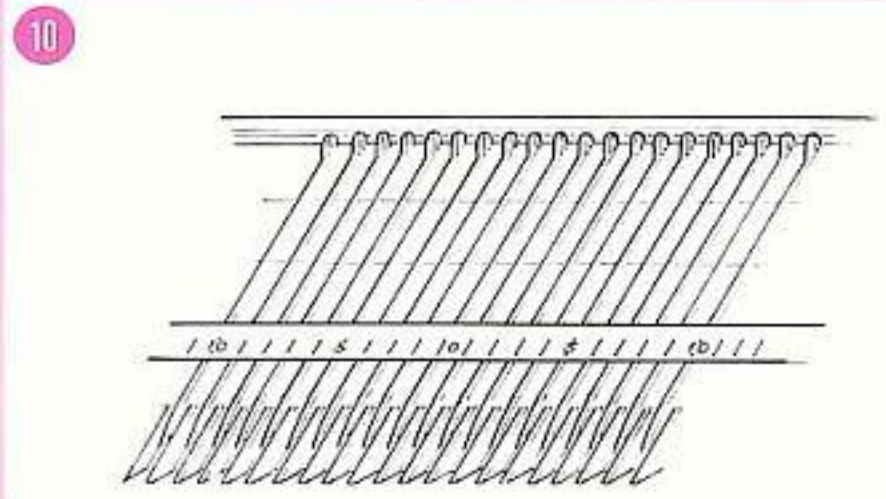
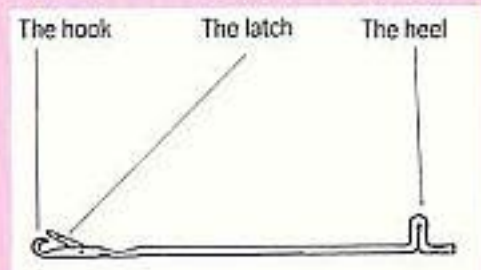

STITCH FORMATION

13 Stitches are formed by the needles moving up and down in the grooves. The needle starts in working position 2. The stitch is behind the latch and the yarn for the next stitch is placed in the hook.

14 As the carriage moves across, the needles are pushed down in the groove and the stitch slides up the needle closing the latch.

15 The stitch slides over the needle and the yarn for the new stitch is pulled through. As the carriage goes past the needle it is moved back to working position 2. The new stitch drops behind the latch and the needle is ready for another stitch to be made.

16 The stitch size dial determines the size of the stitch. If the outside dial is opposite a low number a small stitch is formed. If the outside dial is opposite a high number a large stitch is formed.

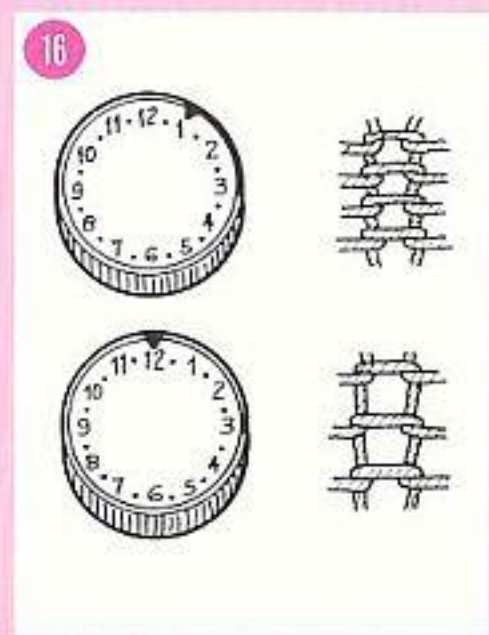
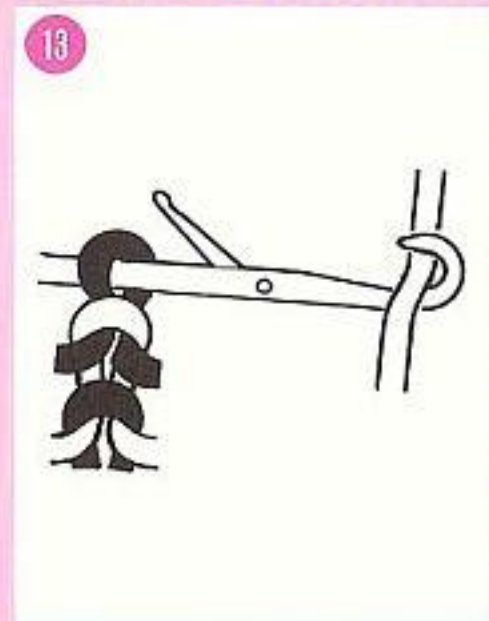
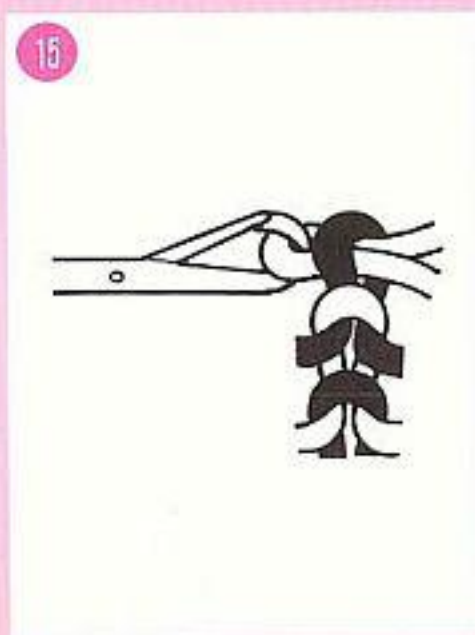

Stitch Size Dial	Description	Hand Knitting Needles millimetres
1-4	Double Knitting	3½-3½
4-6	Aran	4-5
6-8	Chunky + Mohairs	5½-6
8-10	Novelty Mohair Yarns	6½+
10+	Very Heavy Yarns	6½+

17 Moving the carriage

Do not press down on the handle.
Hold the carriage gently and pull it and push it as illustrated.

18 Needle selector switch

Practise moving the carriage and using the needle selector switch.

17

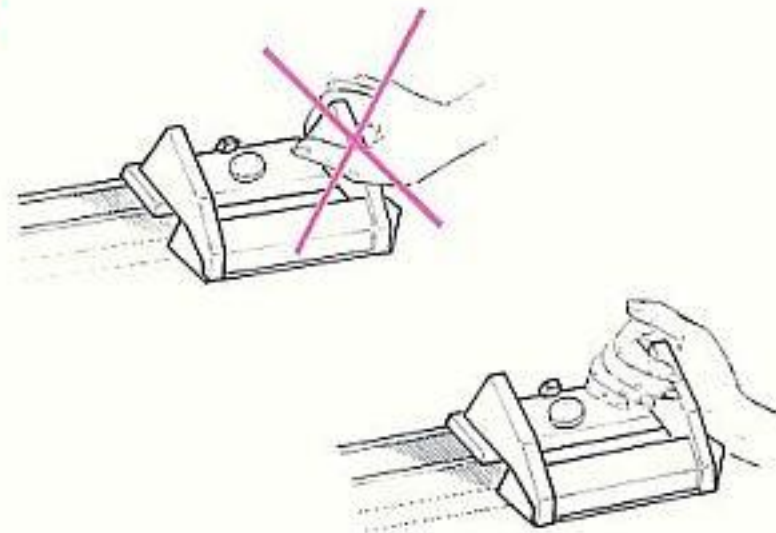

18

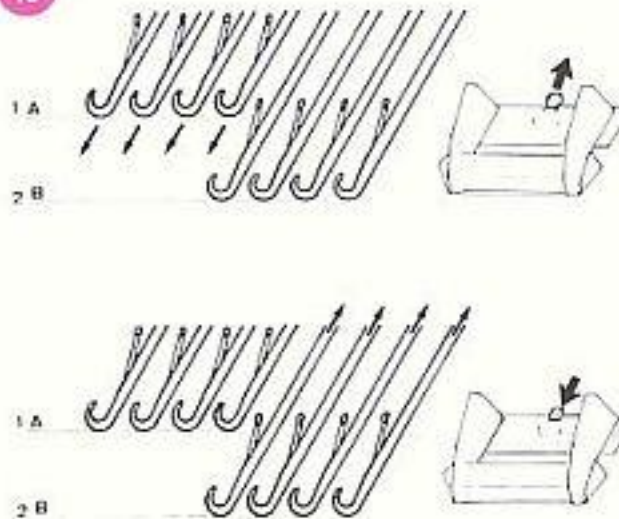

When the needle selector switch is pushed out: needles will come forward from working position 1 to working position 2. (A) Needles in working position 2 will stay in that working position(B). When the needle selector switch is pushed in: needles in working position 1 will stay in working position 1. (A). Needles in working position 2 will return to working position 1 (B).

LET'S MAKE A JUMPER

The back

- 1 Use the comb to move the number of needles given for your size in the pattern into working position 2.
- 2 Use the comb to return the alternate needles to the non-working position (position '0').
- 3 Hook the comb(s) into the comb holder slot on the front of the machine. Make sure all the latches of the needles are open. The comb is in place correctly if it is lifted slightly and tipped towards the front across the needle bed. It remains in place for the first pass of the carriage.
- 4 When knitting on less than 29 needles, use one comb. Slide the small bar weight through the clips on the comb. Place the cast-on comb over the needles in working position 2. It should be centred at '0'.
- 5 When using up to 57 needles, use two combs. Assemble them with the small bar weight. Lay the combs over the needles in working position 2, placing one comb at each side of '0'.

- 5 Use enough combs to cover the needles in use. You may need both bar weights to attach them together. Be sure to centre them on the needle bed at each side of '0'.

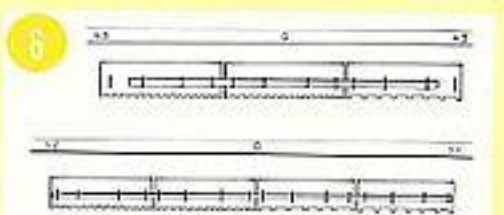
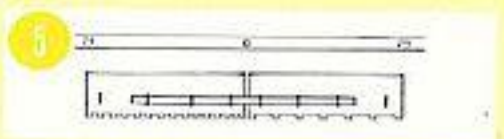
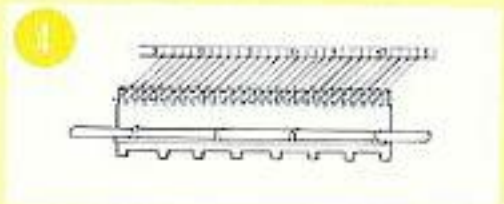
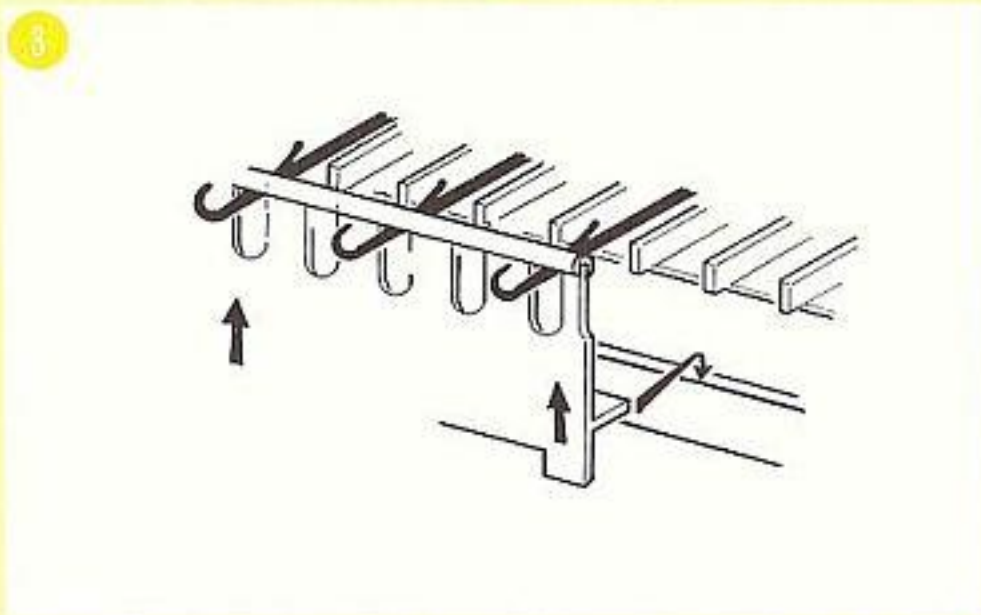
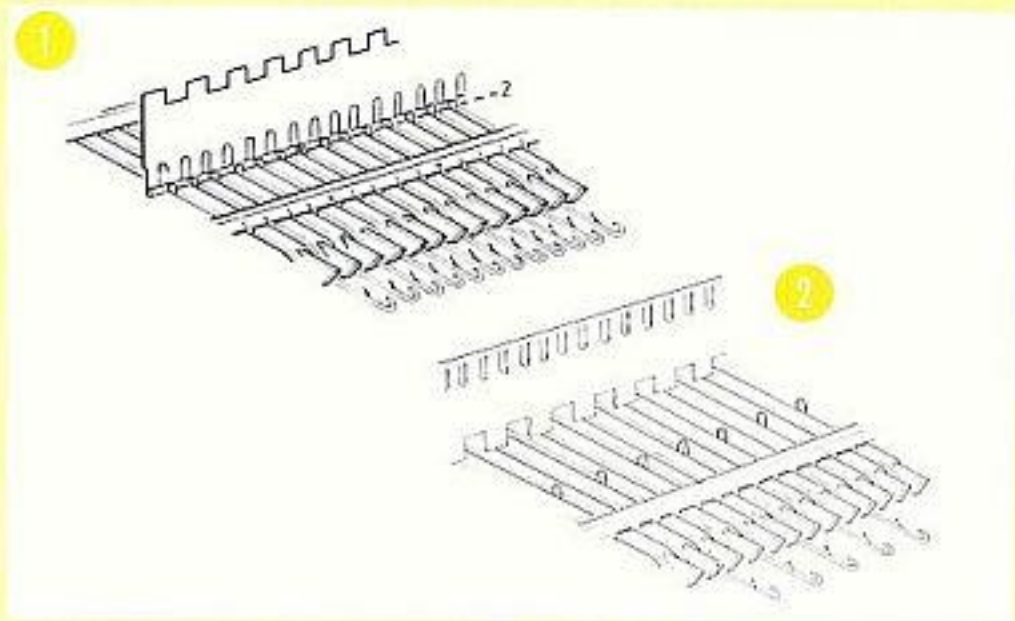

- 7 Clip the yarn in the yarn clip on the right hand table clamp.
- 8 Move stitch size dial to 4.
- 9 Press the needle selector switch in.
- 10 Lay the yarn over the needles with the latches open. Hold the yarn in place across the needles with your left hand. Pass the carriage across the needles, letting the yarn slip gently through the fingers of your left hand.

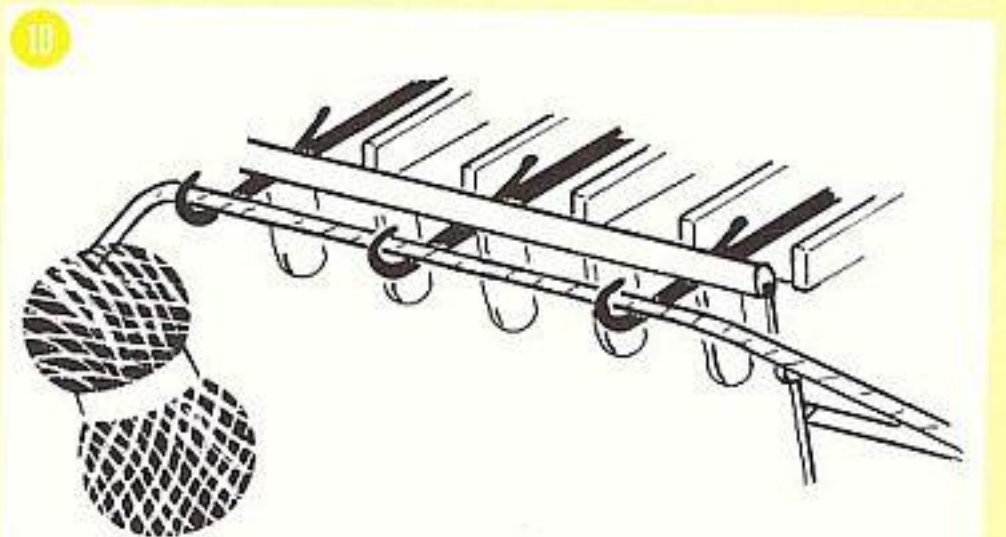
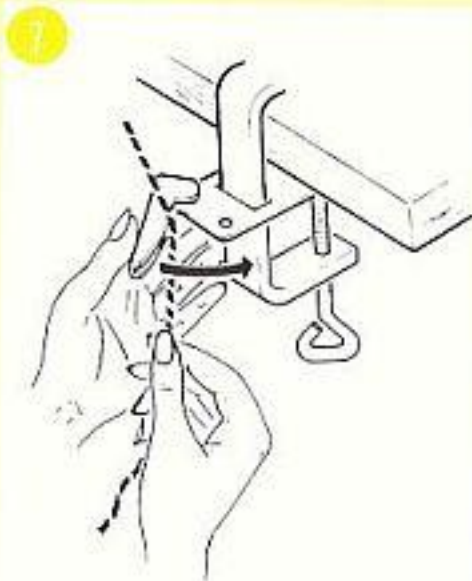

11 Take the rib of the cast-on comb out of the comb holder slot on the front of the machine and gently pull down on it. The needle selector switch remains in. Do not lay yarn across the needles. Pass the carriage across the needles. The carriage is now on the right, the needles are still in working position 1.

12 Push the needle selector switch out. Do not lay yarn across the needles. Pass the carriage across the needles again. This operation moves the needles automatically from working position 1 to working position 2. Lay the yarn over the needles and knit the number of rows stated on your pattern for the rib. Knit the last row with the needle selector switch pushed in. The needles move down to working position 1.

11

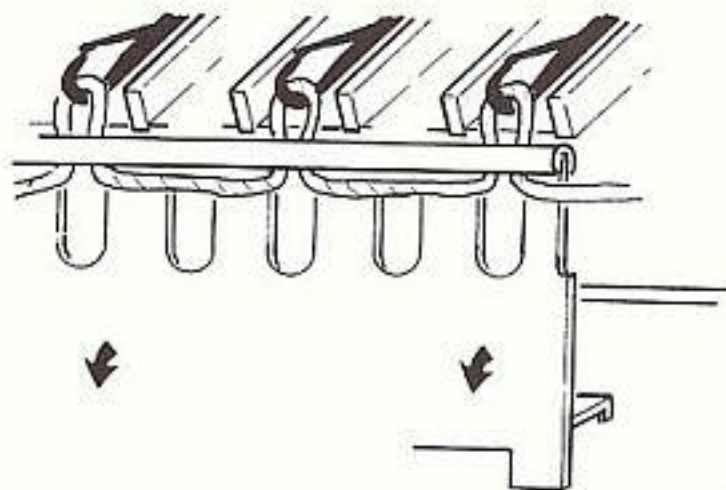

12

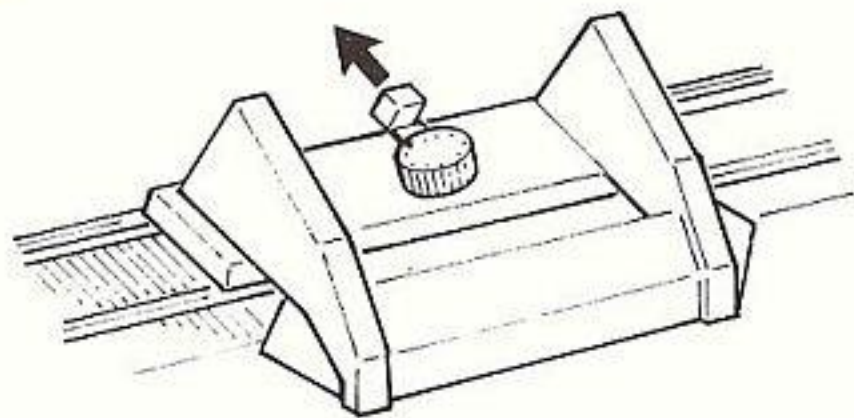

13 Bring up to working position 1 all the alternate needles in non-working position 0.

14 Lift the comb so that the top is resting below the needles. Using the eyelet tool pick up the loops in front of the comb covers and lift them onto the empty needles.

15 Bring the needles forward to working position 2.

16 Set the stitch size dial to 7.
Make sure that all latches are open.
Press the needle selector switch out.

Lay the yarn across the needles. Pass the carriage across the needles. Let the yarn slip easily through your fingers. Repeat this operation going in the opposite direction. Continue knitting. Each time you pass the carriage across you are knitting a row. Knit as many rows as needed for your size in the pattern. Knit the last row with the needle selector switch pushed in. The needles move down to working position 1.

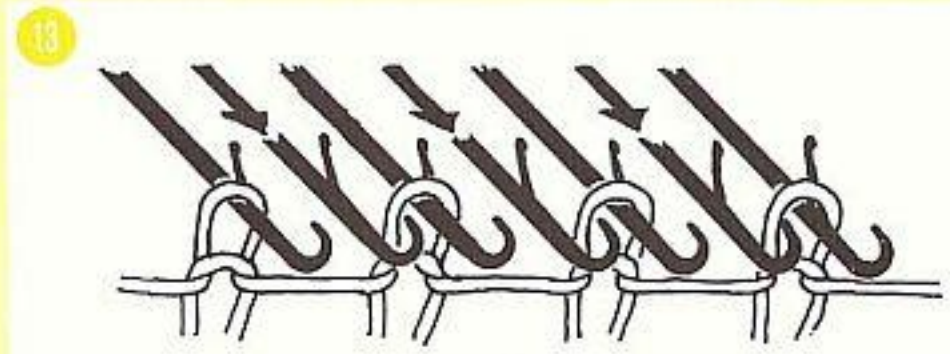
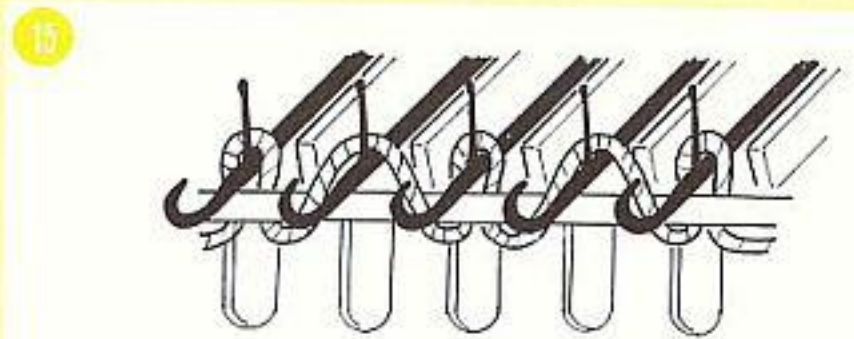
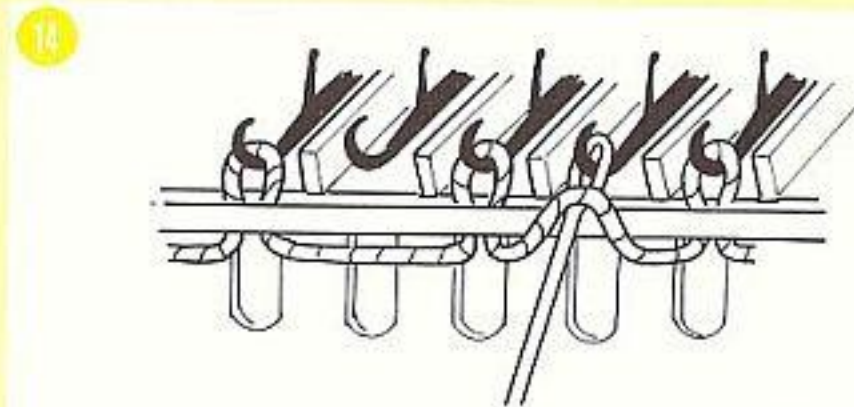

16 Stocking stitch

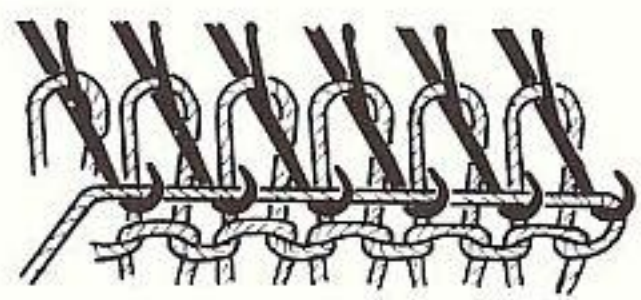

Casting off

- 17** With your left hand, hold the knitting between your thumb and forefinger as illustrated. Pull the knitting slightly to open the stitches. Using the latch tool, unhook the first stitch on the side next to the carriage.

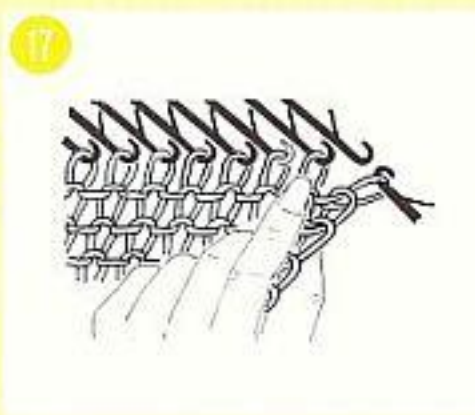

- 18** Slide this stitch behind the latch. Keeping the latch open, unhook the second stitch and slide this behind the latch (two stitches behind the latch).

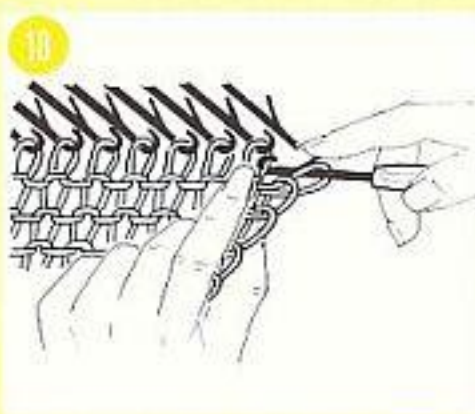

- 19** Lay the yarn over the hook of the tool.

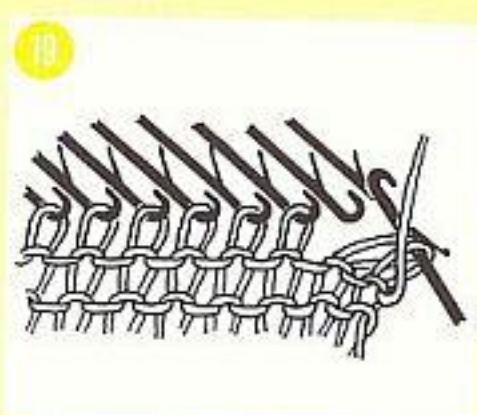

- 20** Pull the tool downwards to pass the yarn through both stitches. A new stitch is formed. Hook the next stitch. Let both stitches slide behind the latch of the tool. Lay the yarn over the hook. Pull the yarn through both stitches. Continue across to the last stitch.

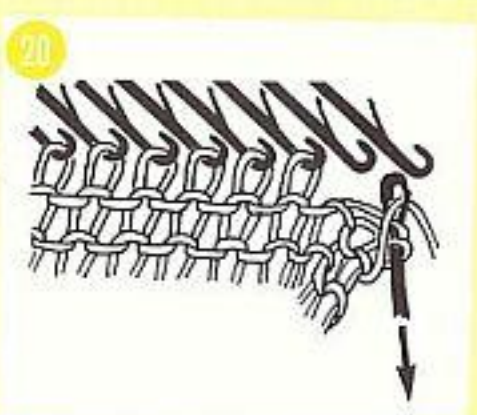

- 21** Break the yarn and pull it through the loop of the last stitch.

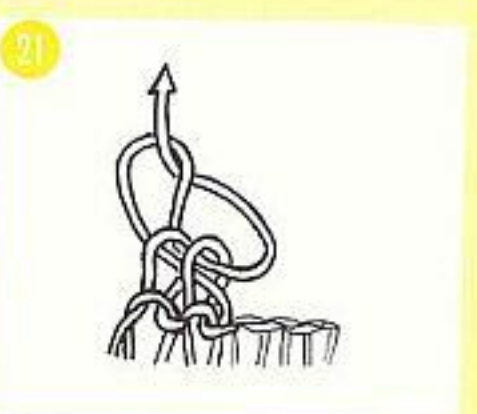

The Front

22 The front of the jumper is exactly the same as the back except for the neck shaping. Your pattern will tell you exactly which row to start the shaping for your size. Follow the instructions for the back which you have just completed until you reach one row before the neck begins. Knit the next row with the needle selector switch pushed in. This will return all the needles to working position 1. Your pattern will tell you how many stitches need to be cast off in the centre of your knitting.

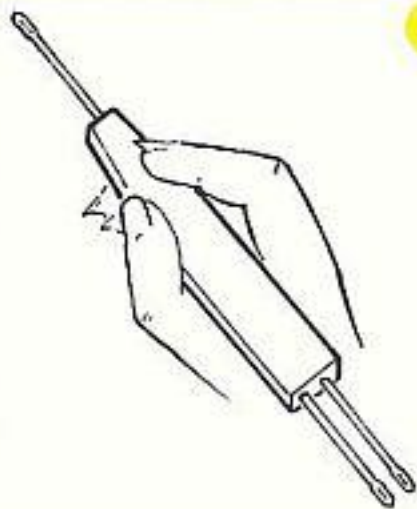

Hold the eyelet tool in your hand like a pencil.

22

23 Hook the single eyelet of the eyelet tool into the hook of the needle holding the first stitch to be cast off. Pull the tool towards you, keeping the needle and the eyelet tool in a straight line. The stitch slides behind the needle latch.

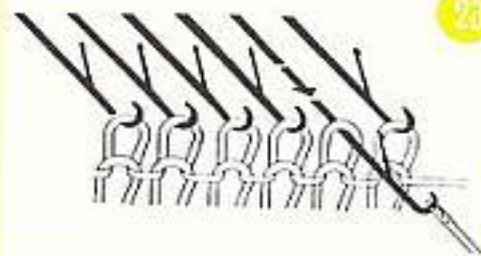

23

24 Push in on the needle. The stitch moves onto the eyelet tool.

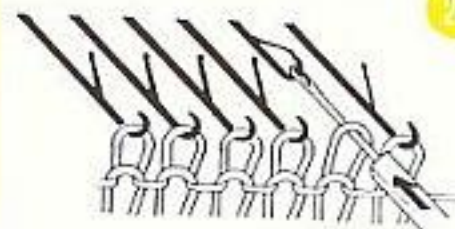

24

25 Remove the eyelet tool from the needle, being careful not to drop the stitch. Hook the eyelet tool onto the desired needle hook.



25

26 Tilt the tool towards the back. The stitch slides onto the new needle hook.



26

27 Bring the needle out to working position 2 making sure that both stitches slip behind the latch. Push the empty needle down to non-working position 0.

28 Place the needle with two stitches into holding position 3. Clip some matching yarn in the right hand yarn clip and place the yarn over the hook of the needle.

29 Lower the needle into working position 1 to form a new stitch. Repeat this operation until the required number of stitches has been cast off. Release the yarn from the right hand yarn clip.

30 Push all the needles to the left of the empty needles to holding position 3.

Bring the needles on the right to working position 2 and make sure the stitches are behind the latches. Lay the yarn across these needles and knit one row. The needles in holding position 3 will not knit. The neck shaping continues on these stitches only. Your pattern will tell you on which row you next have to decrease for your size.



31 Using the single eyelet tool, transfer the stitch at the neck edge one needle in. Move the just emptied needle down to non-working position 0.

32 Carry on decreasing as given for your size in the pattern until the first part of the shaping is complete. Knit any rows without shaping that the pattern may give for your size. Cast off as you have already done for the back. See page 13.

Once this casting off is completed bring the needles in holding position 3 back to working position 2. Remove carriage at right of machine and place on left hand side of machine. Place yarn in left hand yarn clip. Knit to match other side of neck reversing shapings.

Sleeves

33 Using the number of needles given for your size in the pattern cast on as before for rib and make the rib. See page 9. When you have completed the rib, change to the main tension and knit the number of rows given in the pattern to the first increase.

34 On the carriage side of the knitting, move one needle to working position 2. When the carriage is taken across the needles, that one will also be knitted. Do the same on the other side of the knitting on the next row

35 Follow the pattern, increasing when necessary, and when you have completed the sleeve cast off. See page 13. Repeat the instructions for the second sleeve.

Neckband

36 Sew the front and back together at one shoulder. With the wrong side of your garment facing you, use the tool to pick up the edge stitches at the neck. Your pattern will tell you exactly how many stitches to pick up on each section of the neck. Bring the needles into working position 2 with the stitches behind the latches and knit the number of rows given on your pattern. Cast off loosely. See page 13. Sew your garment together following the instructions for making up in your pattern.

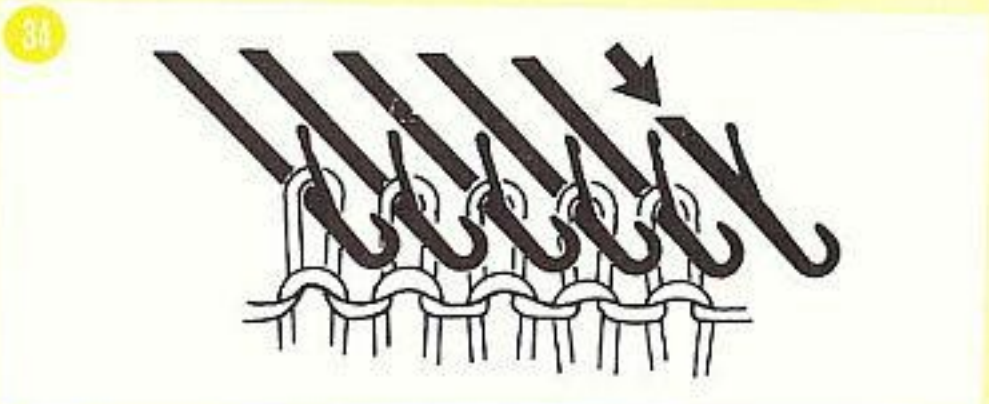
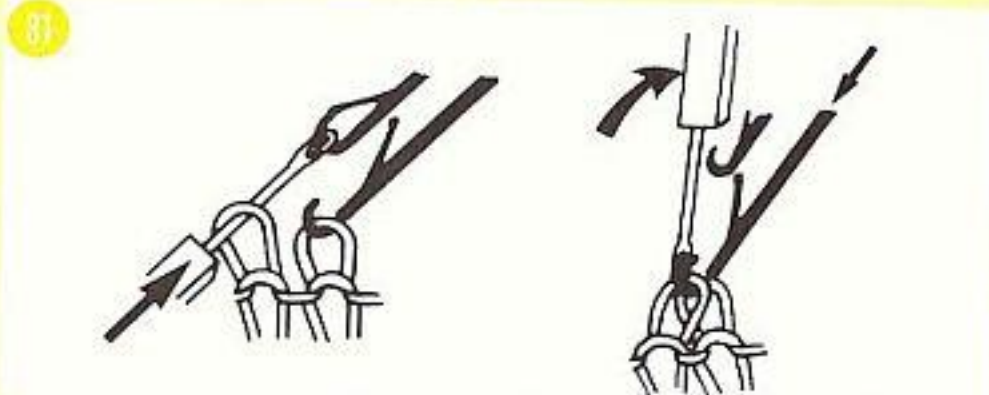

FOR A MORE PROFESSIONAL TOUCH

Finding the correct stitch size dial setting for your pattern

At the beginning of a pattern the number of rows and stitches measured over 10 cm is always given. To ensure that the garment comes out to the right size it is vital that you find the number on the stitch dial which will give this measurement.

Using the instructions for chain casting on (page 23) cast on 40 stitches in the yarn you have chosen for your garment. The Singer Style patterns which have been created for your machine always give a suggested stitch size. Turn the stitch size dial to one whole number below this and knit 40 rows. Use a piece of different coloured waste yarn and

knit two rows, then knit 40 rows on the suggested stitch size. Knit another 2 rows in the waste yarn and then knit 40 rows using one whole stitch size above the one suggested. Knit two rows in the waste yarn and remove the knitting from the machine.

Leave the knitting for at least 2 hours and preferably overnight to allow the yarn to go back to its natural shape. Lay the knitting on a flat surface and using a tape measure count the number of rows and stitches in 10 cm. Whichever stitch size gives you the correct measurement, this is the one you should use when knitting your garment.

Increasing. Fully fashioned (Italian increase)

1 This method of increasing allows you to increase at both sides of your garment at the same time and adds a decorative finish. Using the double eyelet tool, transfer the two edge stitches one needle out.

Using the single eyelet tool or the hook tool, take the heel of the next stitch and hang it onto the empty needle.

This prevents a hole from forming.

4 Alternative method: On the carriage side, take the heel of the first stitch into the hook of the latch needle tool, and crochet a chain around the needles to be increased.

Hang the loop on the last needle, as for chain casting on. See page 23.

Increasing. Several stitches

2 On the carriage side, move the desired number of needles for the increase into holding position **3**. Manually pass the yarn under and over each empty needle, making sure the yarn lays under the last needle as illustrated.

The yarn must be behind the latches of the needle.

3 Push back on the needles until they are in working position **2**. Knit one row.

Hang one or two edge weights on the newly formed stitches.

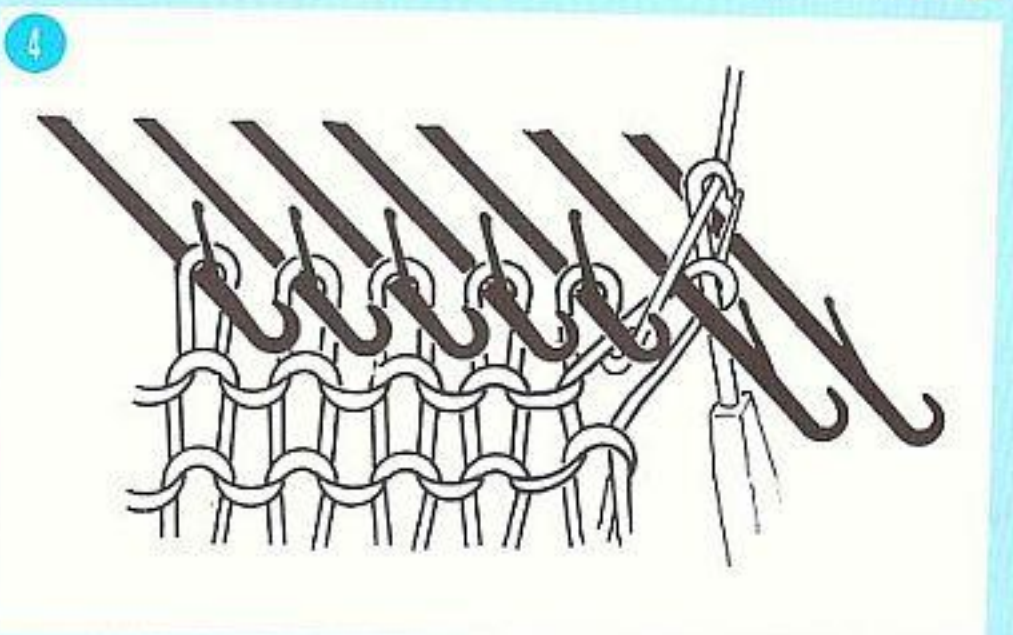
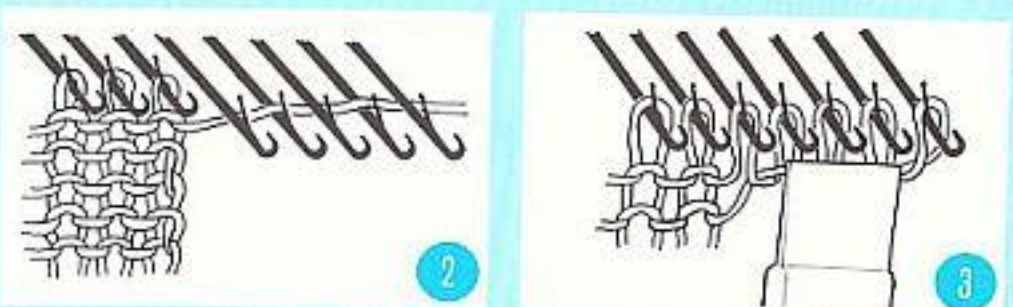

Fully fashioned decrease. (Italian decrease)

- 5 This type of decrease can be done inside the knitting regardless of the position of the carriage. Using the double eyelet tool, move the two edge stitches one needle in. The second needle now has two stitches on it. Make sure the stitches are behind the latch. Lower the empty needle to non-working position 0 and knit.

Decreasing several stitches

- 6 This decrease is done on the carriage side. It allows you to obtain a sharp angle when shaping the bottom of an armhole for example. Proceed as follows:
Transfer the edge stitch onto the next needle.
Place the needle with 2 stitches into holding position 3.
Lay the yarn manually into the needle hook.

- 7 Lower the needle into working position 1 to form a new stitch.
Repeat this operation until the required number of stitches has been decreased.
Remember to always return empty needles to non-working position 0 and bring all the needles to working position 2 with the stitches behind the latches before you re-commence knitting.

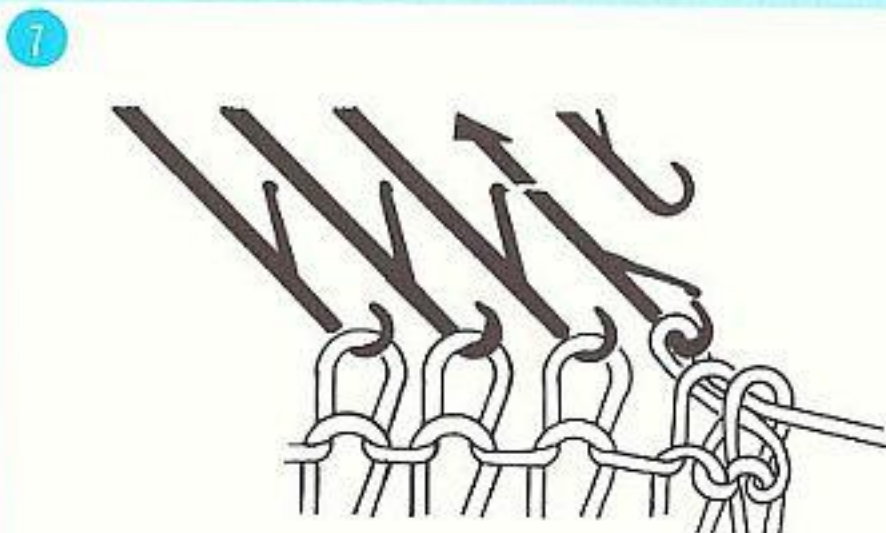
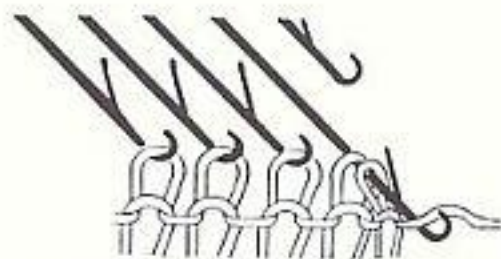
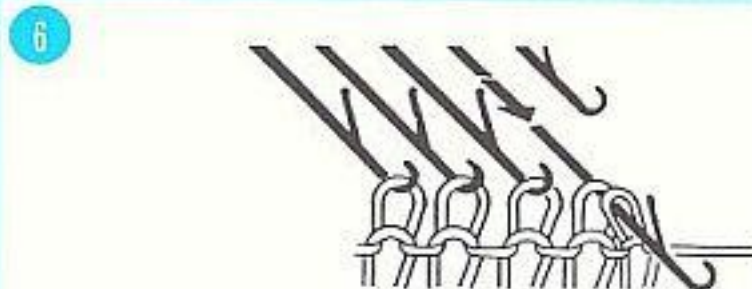
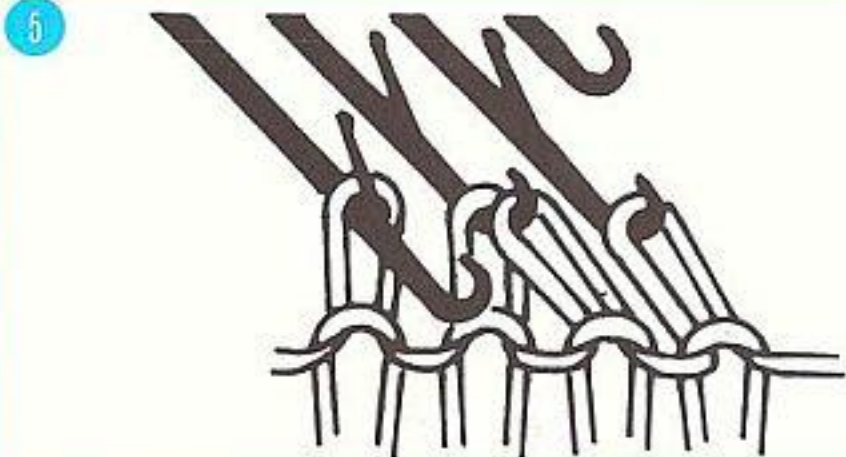

Alternative ribs (latch tool ribs)

8 Ribs made in this way are made after the main piece of the garment has been knitted.

Use the comb to move the desired number of needles into working position 2.

The latches of the needles must be open.

Hook the comb(s) into the comb holder slot on the front of the machine.

9 Using different coloured waste yarn clip the end of the yarn into the yarn clip on the right hand clamp.

Set the stitch size dial to 4.

Press the needle selector switch in.

Lay the yarn over the needles with the latches open.

Hold the yarn in place across the needles with your left hand.

Pass the carriage across the needles, letting the yarn slip easily through the fingers of your left hand.

Take the rib of the cast-on comb out of the comb holder on the front of the machine and pull down on it.

The needle selector switch remains in.

Do not lay yarn across the needles.

Pass the carriage across the needles.

The carriage is now on the right, the needles are still in working position 1.

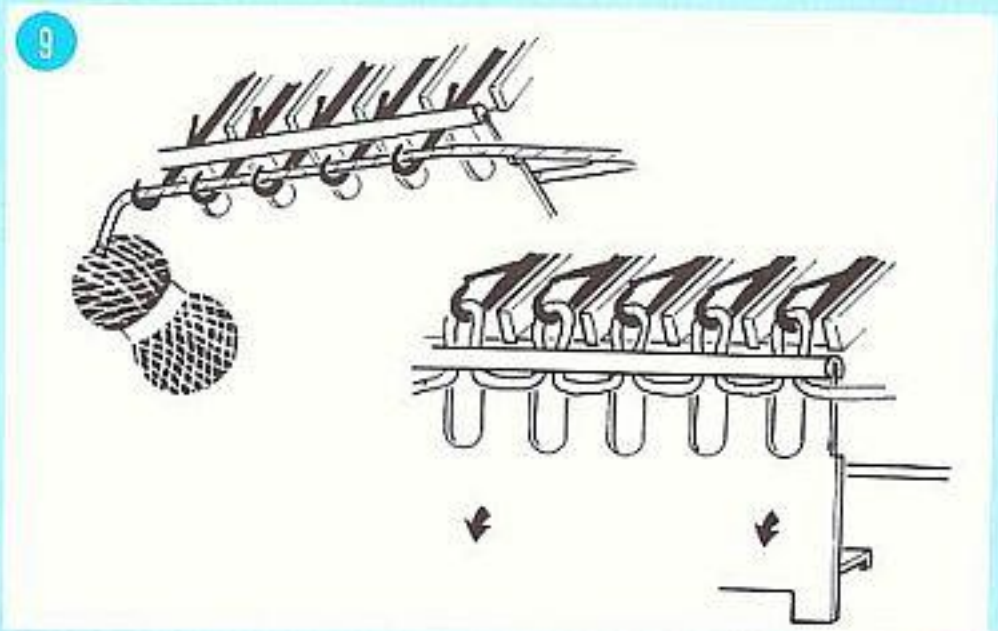
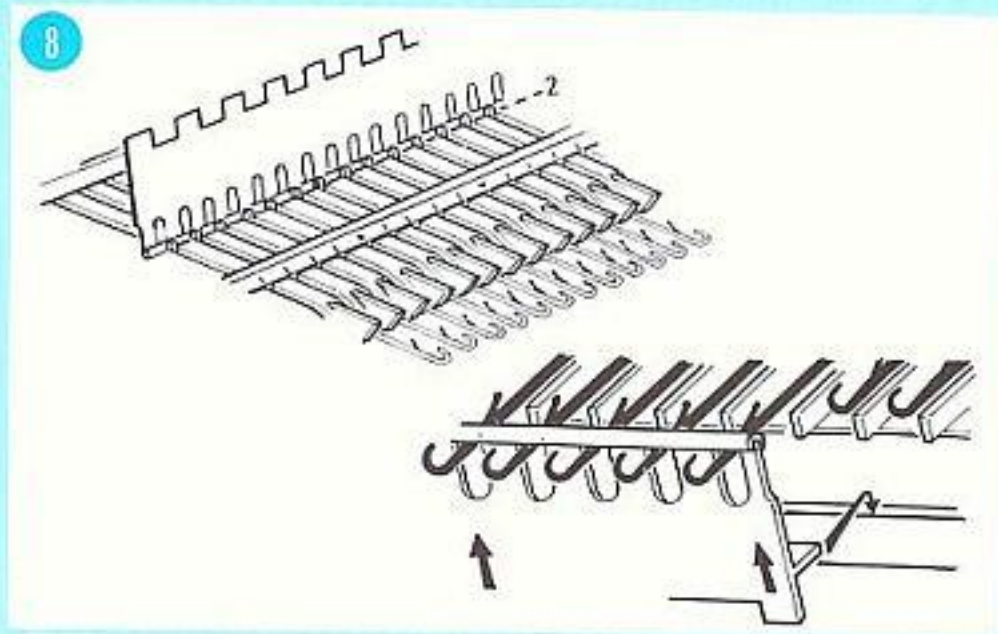

10 Push the needle selector switch out. Do not lay yarn across the needles. Pass the carriage across the needles again. This operation moves the needles automatically from working position 1 to working position 2. Knit a few rows in the waste yarn, then continue in main yarn. Knit according to your pattern excluding the section on ribs.

11 When the piece is completed turn it upside down and with wrong side facing pick up the first row of loops in the main colour with the eyelet tool and place one on each needle. Bring all the needles to working position 2 and make sure the stitches are behind the latches. Using the size for rib tension given in your pattern knit half as many rows as are stated in the pattern for the rib. Knit one row with the needle selector switch pushed in.

12 Lift the first stitch selected to be a "purl" stitch off the needle and allow it to run down to the waste yarn. A kind of ladder is formed.

13 Catch the stitch in the hook of the latch tool and slide it behind the latch.

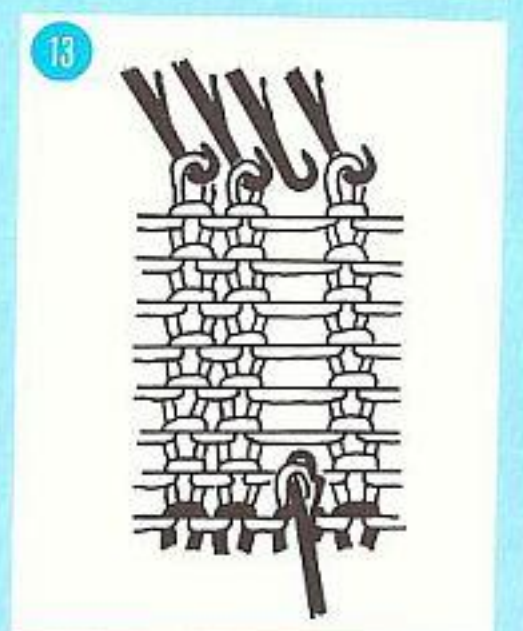
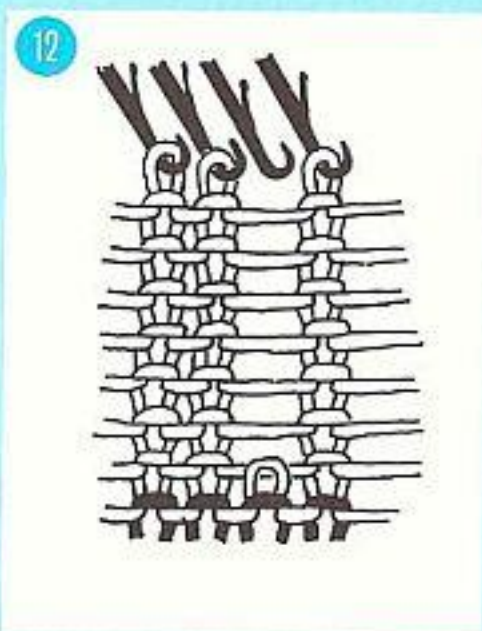
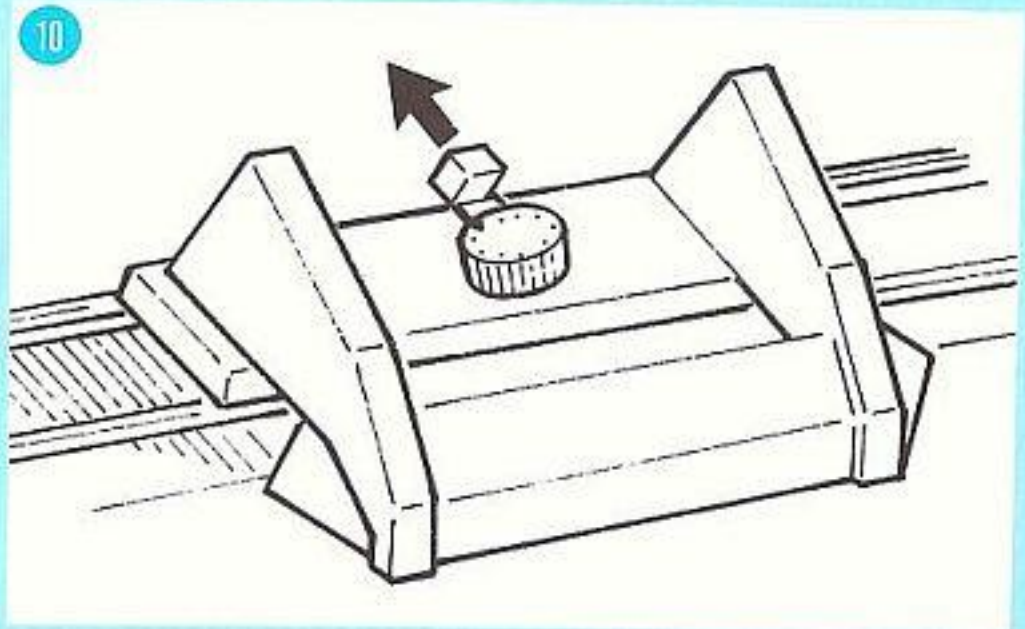

14 Take the first yarn of the "ladder" into the hook.

15 Pull the tool down until the latch is closed, and a new stitch is pulled through. Slide this new stitch behind the latch.

16 Hook the next step of the ladder and pull it through the stitch just formed. Continue in this way, all the way up the ladder, and hang the last stitch onto the empty needle.

17 Continue in this way across the knitting at regular intervals to create a rib pattern. Cast off evenly, and pull the end of the waste yarn so that it unravels from the work.

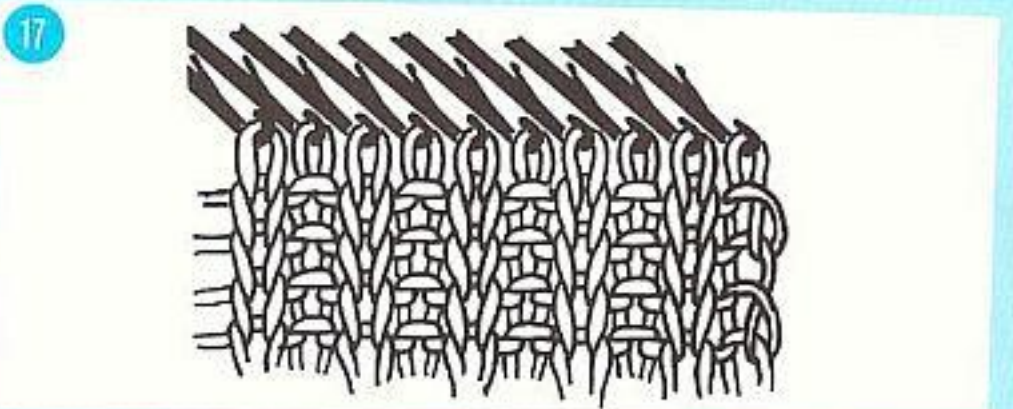
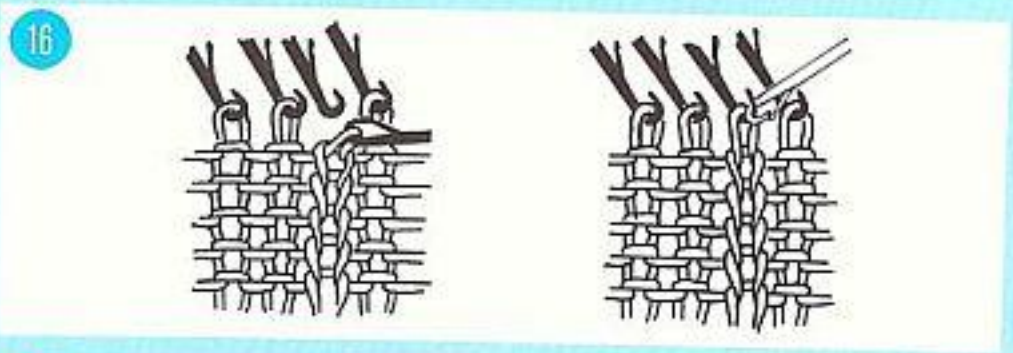
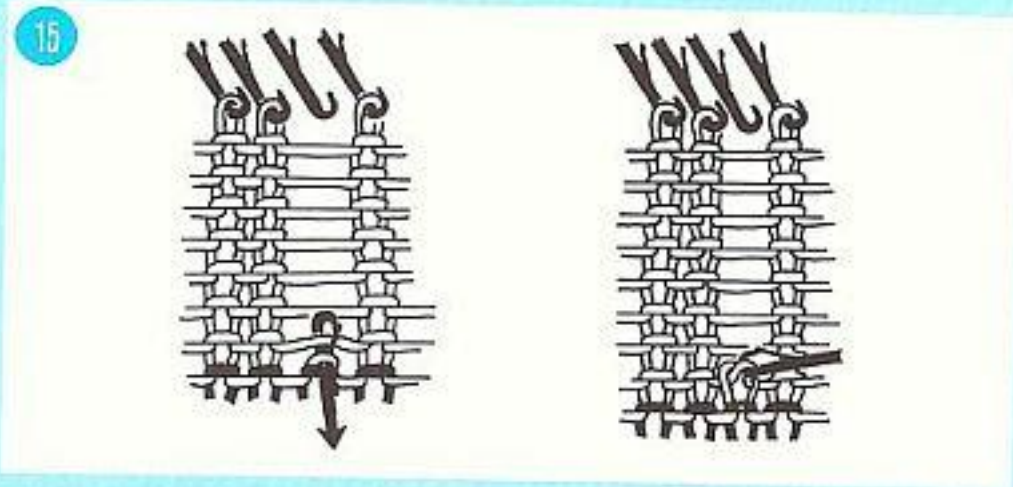
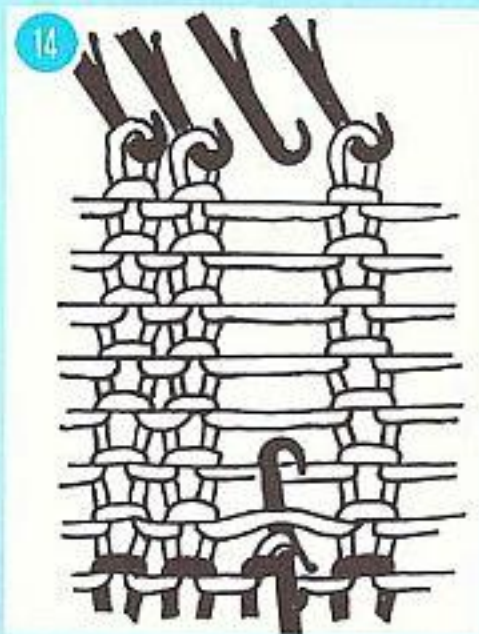

Chain casting on.

18 This is a closed edge cast on which can be used for button and buttonhole bands. With the carriage on right hand side, bring the number of needles given for the button band in your pattern to holding position 3. Clip the yarn into the left yarn clip.



Hold the yarn above the needles with your left hand. Catch it with the hook of the latch needle tool.



Pass the loop under the first left-hand needle.



Bring it up between the first and the second needle.



Let the loop slide behind the latch of the tool. Catch the yarn above the first needle.



Pull the tool downwards to form a loose stitch.



Pass the tool with the new stitch under the second needle and bring the tool up between the second and third needle. Continue across, as above until the last but one needle.

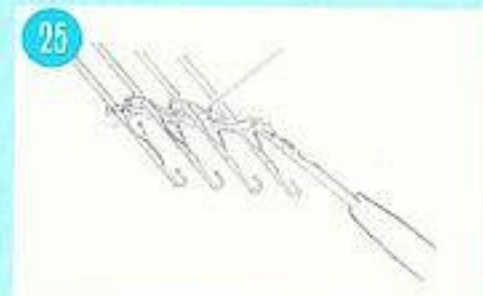

Place the last loop on the last needle. Bring the yarn under this needle and around to the carriage side.



Bring the needles back to working position 2. The needle latches must be open.



Lay the yarn from right to left across the needles and knit.

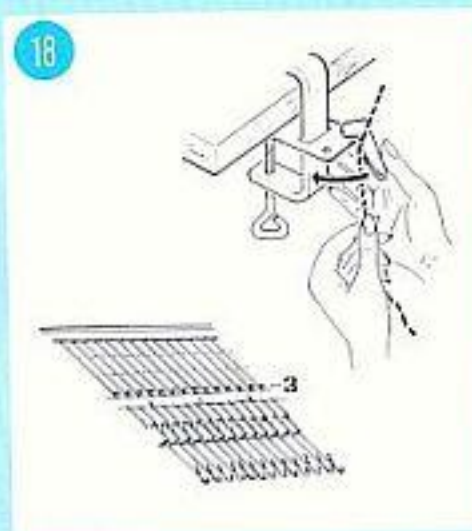

28 Press out the needle selector switch and adjust the stitch size dial to the stitch size for your yarn.

Knit one row, letting the yarn slip easily through your fingers.
Add an edge weight after the first row to hold the stitches in place.
Knit the number of rows required in your pattern.

Buttonholes

29 Place a small piece of different coloured waste yarn over the hooks of the needles where the buttonhole is to be made.

Lower the buttonhole needles by pulling down on the heels in order to close the latches and knit the waste yarn.

Bring the needles back to working position 2. Continue in main yarn placing buttonholes as required.

When the garment is finished remove the waste yarn and back stitch through the stitches to secure them.

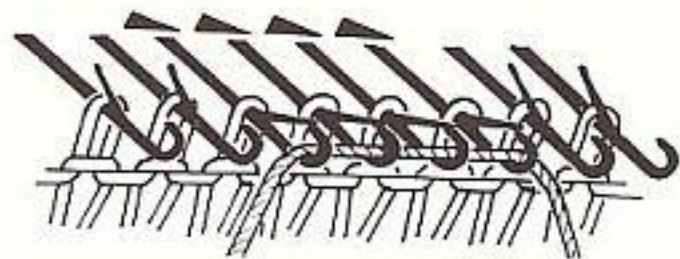
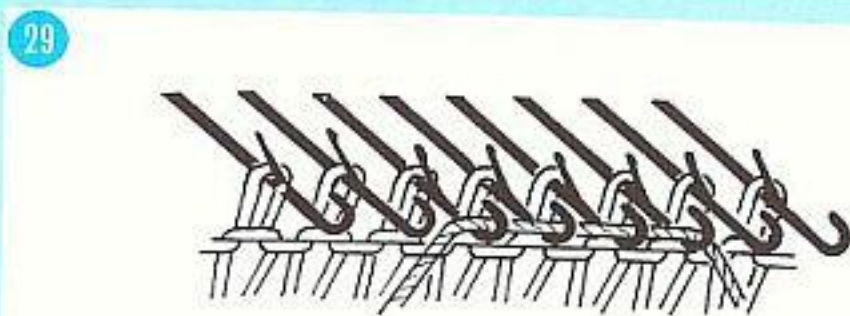
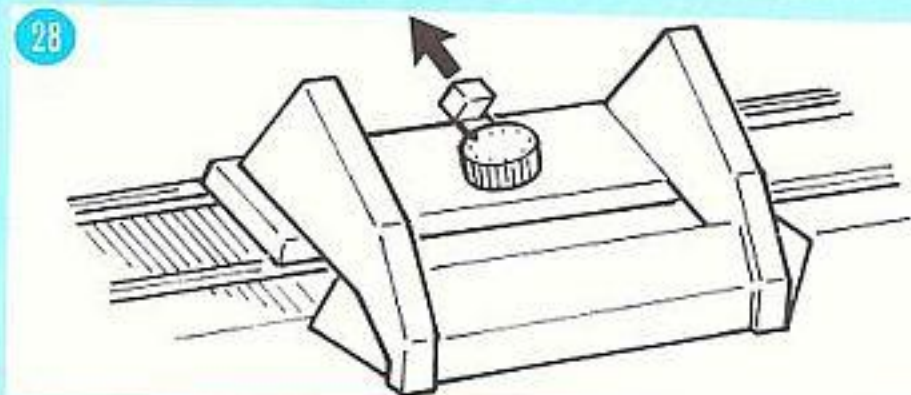

Important

As buttonhole and button bands are always doubled over when they are sewn onto a garment it is important that 2 buttonholes are made in the same row equidistant from the centre stitch of the knitting so that the button can pass through the band.

FANCY STITCHES

Tuck stitches (needles in holding position)

- 1 Begin with all the needles in working position 2.
Needle selector switch is pressed out.
Bring the needles required for tuck stitch to holding position 3.
Please note: never select two or more needles into holding position 3 next to each other on any row.
Knit 1, 2 or 3 rows according to the thickness of your yarn.

- 2 Return needles from holding position 3 to working position 2.
Knit one row.

Lace patterns

- 3 With all the needles in working position 1, transfer the stitch required for your pattern onto its adjacent needle.
Bring needles forward to working position 2.
Knit two rows.
Prepare a diagram before knitting.

1



2

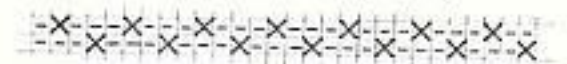
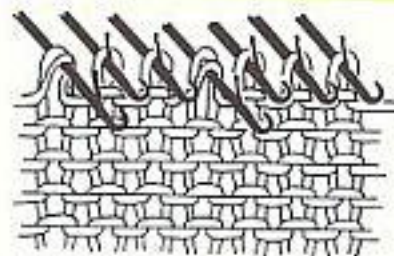

Prepare a diagram before knitting. X = Needles in holding position 3.

3

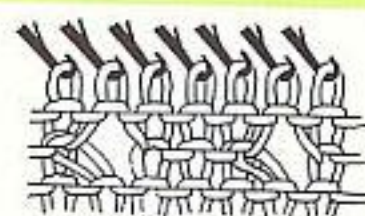

Prepare a diagram before knitting.

Slip stitch

- 4 All needles are in working position 1.
Needle selector switch pressed in.
Bring the needles required for the pattern stitch to working position 2.
The remainder stay in working position 1 to form the slip stitch.
Please note the stitches behind the slip stitches must be knitted at least once every third pass of the carriage, according to the thickness of the yarn.
Prepare a diagram before knitting.

Pulled up stitches

- 5 Needles in working position 2.
Knit in stocking stitch.
Every 3rd, 4th or 6th row, take the heel of the stitch and place it behind the latch of the needle directly above it.
Continue knitting.

4

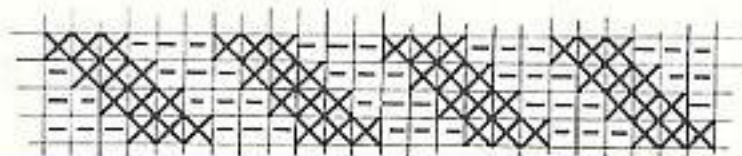
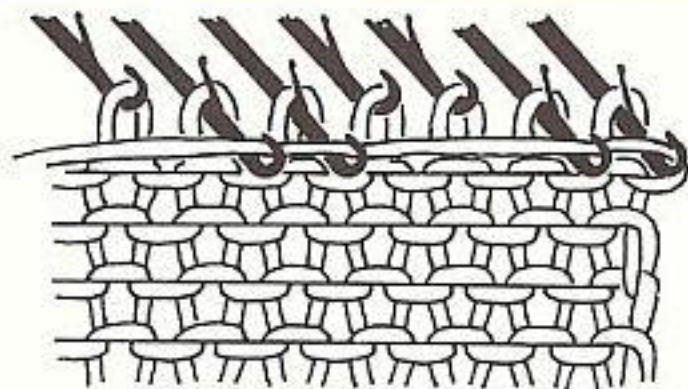

5

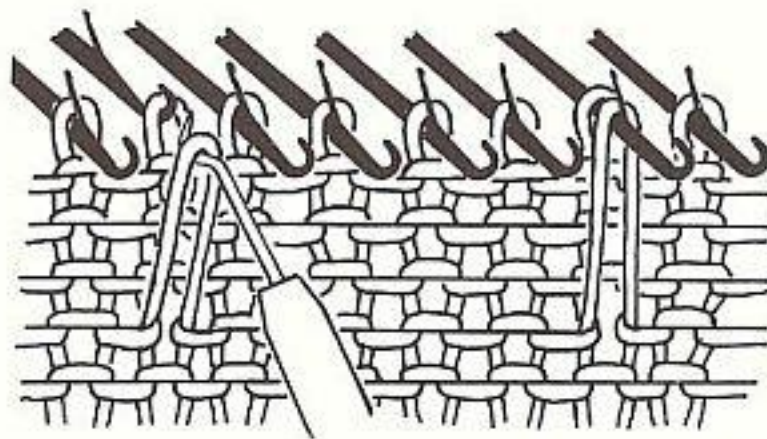

6 Intarsia or picture knitting

Intarsia is a method for pattern knitting with two or more colours without floats of yarn on the reverse side of fabric. Prepare a diagram before knitting. If your pattern is very complex make a complete diagram on graph paper.

7 All needles are in working position 2.

Needle selector switch pressed out.

Use one ball of yarn for each colour.

Lay the yarn across the needles, according to your diagram.

Knit the row and lay the yarns across for the next row according to your diagram.

To avoid a gap between two colours twist the yarn between the needles of the two adjacent colours.

6

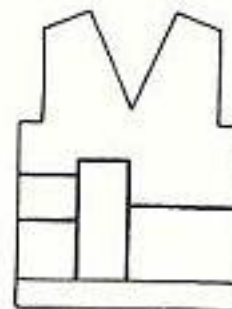
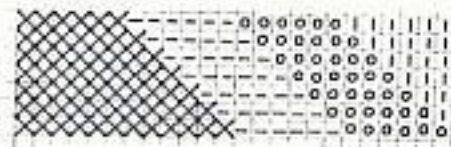

7

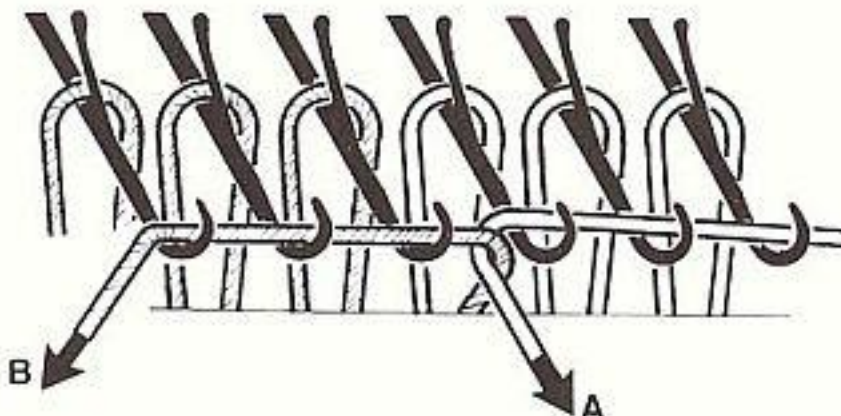
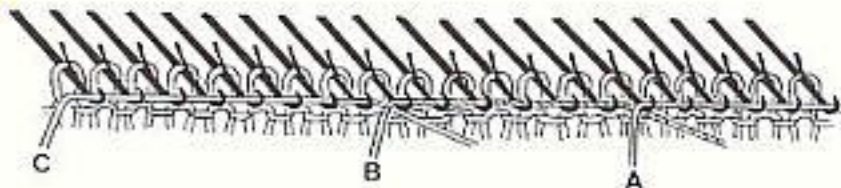

Fair Isle

8 With the carriage on the right, bring all the needles into holding position 3. Bring back to working position 2 the needles for the background colour. Lay the background yarn across the needles and with the selector switch pushed in knit one row. These needles move to working position 1. Bring the needles in holding position 3 to working position 2. Clip the contrast yarn in the left hand yarn clip, lay the yarn across the needles and knit one row. All the needles are now in working position 1. Turn row counter back one number.

9 Bring all needles to holding position and bring contrast colour needles to working position 2 and knit one row. Bring remaining needles to working position 2 and knit with background colour. Turn row counter back one number. Follow the diagrams for your pattern using the steps above.

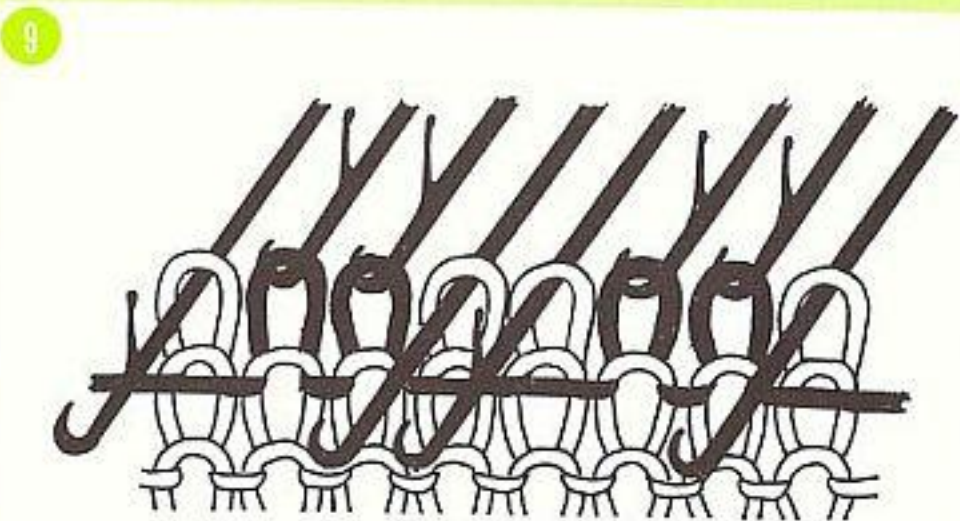
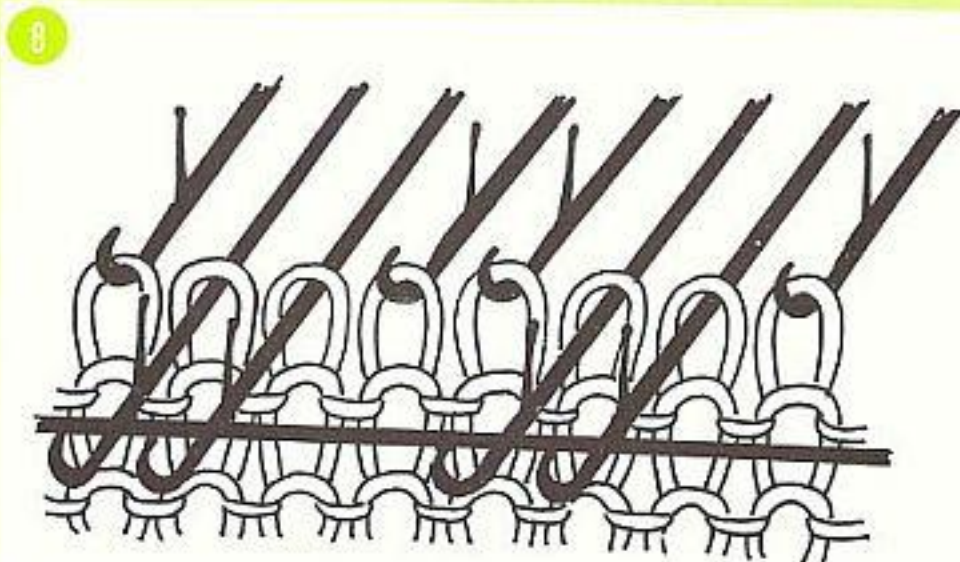

Weaving effect

I A weaving effect is obtained by using two textures of yarn. The main yarn is knitted and the weaving yarn of a heavier or decorative type is passed under needles in working position 2 and over needles in holding position 3. It is possible to leave 1, 2 or 3 needles in holding position 3 according to the desired effect.

II After laying the weaving yarn over and under the needles push the needles in holding position 3 back to working position 2. The weaving yarn must be behind the needle latches. Lay the main yarn across all needles and knit one row.

Prepare your diagram before you start knitting.
Example: X — needles to be put into position 3.

10



11

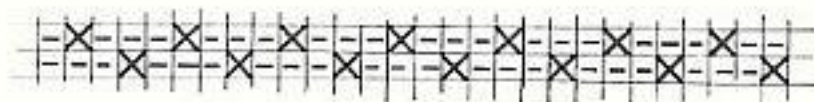
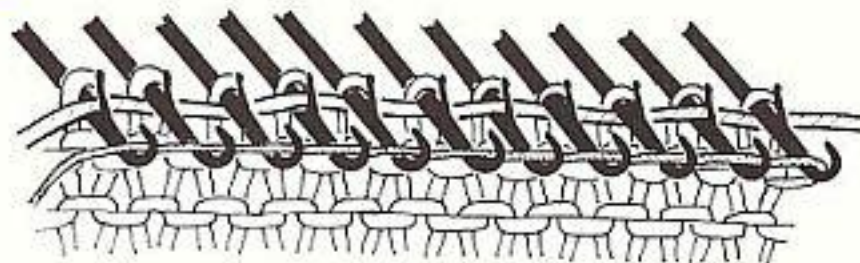

Prepare your diagram before you start knitting. Example: X — needles to be put into position 3.

HELP! WHAT TO DO IF:-

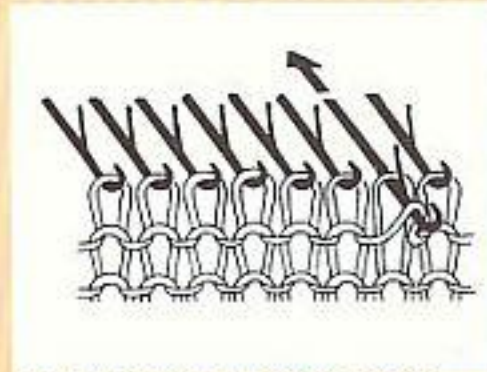

A STITCH IS DROPPED, OR DOES NOT KNIT

Rehang the dropped stitch behind the latch and put the unknitted yarn on the hook.
Pull the heel of the needle down to draw the yarn through.

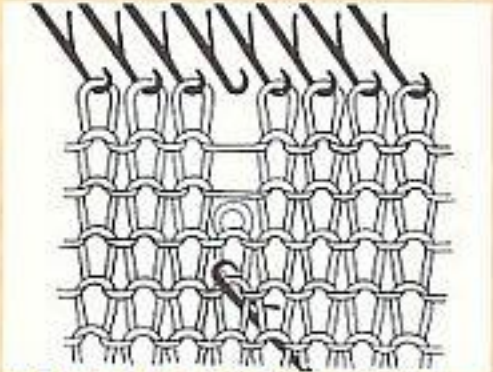

A STITCH DROPS SEVERAL ROWS

Insert the hook and latch needle tool a few rows under the dropped stitch, from the back of the knitting.



Push the tool upwards until the dropped stitch slides behind the latch.
Take the yarn from the row above into the hook of the tool.

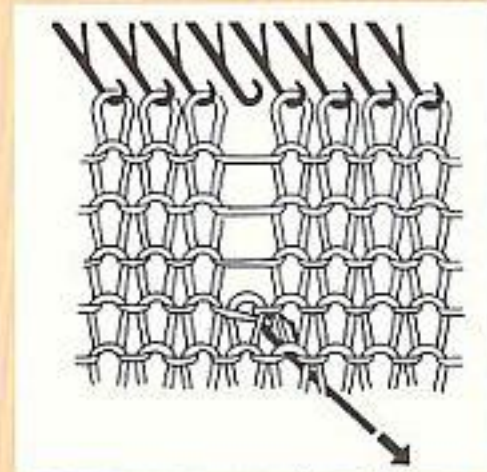

Pull the tool downwards until the latch closes and a new stitch is formed.



When the last loop of yarn has been knitted, transfer the stitch onto the needle with the eyelet tool.

You want to undo one or more rows

1 Place all the needles in working position 1.
Pull the yarn to the side to tighten a few stitches at a time.

2 Pull the yarn up and over the needles.
The stitch from the previous row will slip onto the needle hook.
When you have taken out the number of rows required return the needles to working position 2 and make sure the stitches are behind the latches before starting to knit again.
Remember to re-set your row counter to the correct row.

1

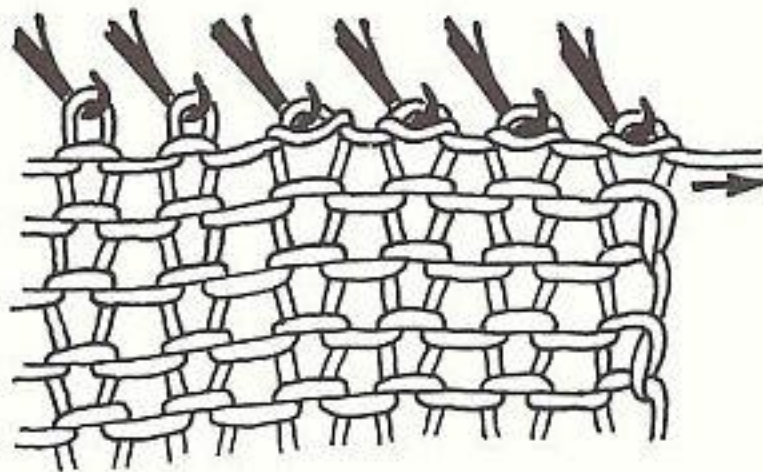

2

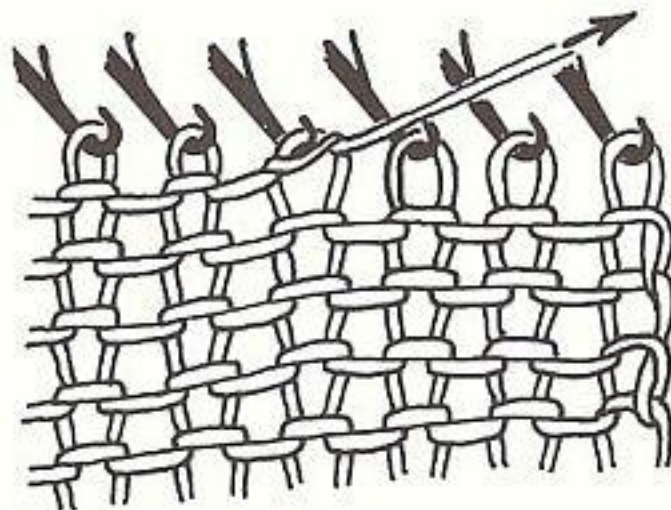

How to change a needle

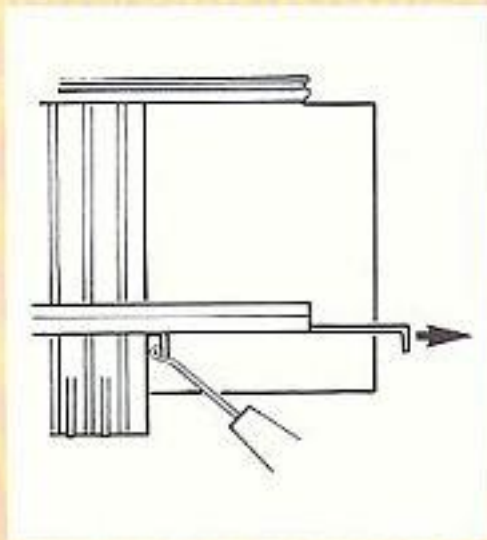

The needles are held in place by a rod. It has a bent end at the right hand side under the graduated scale. With the hook of the latch needle tool, pull the bent end of the rod until the rod clears the needle to be changed.

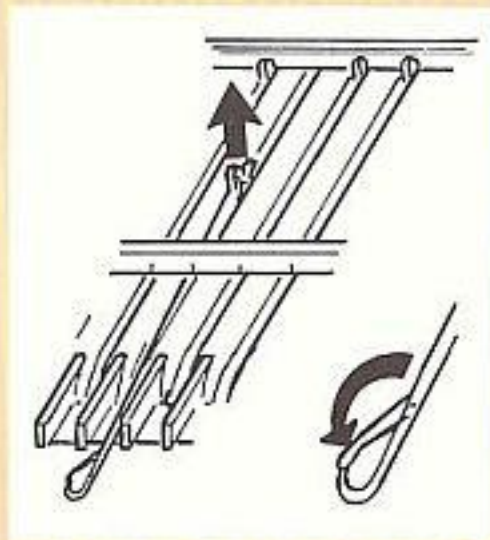

To remove this needle close the latch (it prevents the needle hook from catching the needle retaining spring located under the slide rail). Pull the needle out by the heel, towards the back.

IMPORTANT: If the latch is broken or badly bent, break off the hook and latch from the needle with a wire cutter before changing.

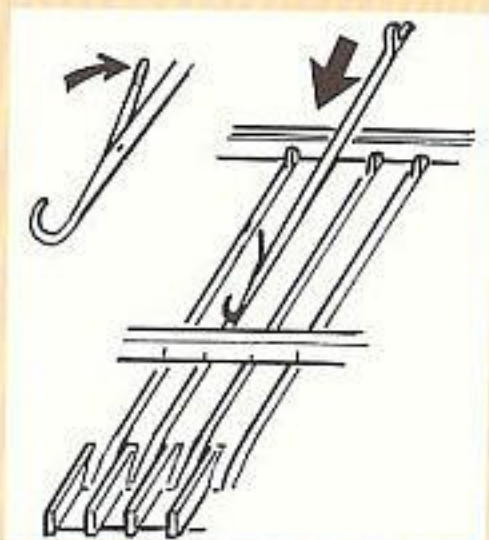

To replace the needle open the latch and slide it under the graduated scale, pressing on the needle body to make insertion easier. Push the needle rod back into place (bent end to the front) to lock all needles in place.

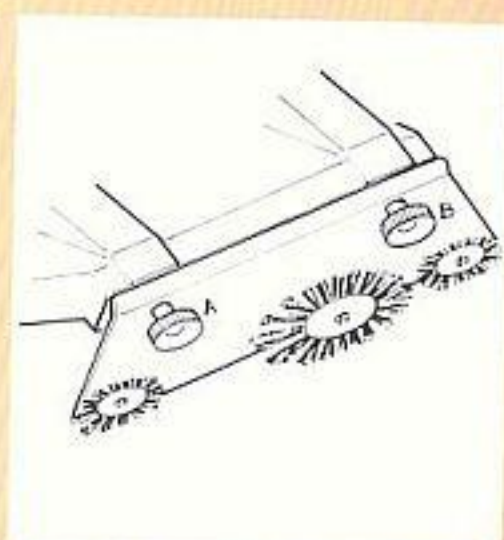

If your carriage jams:

- unscrew knobs A and B found under knitting retainer.
- release knitting retainer and remove it from the carriage. Move carriage away from the knitting.
- re-attach knitting retainer to carriage, align needles and resume knitting.

Care and maintenance

A - Regularly remove the dust and the fluff from your machine, especially the needle grooves, with a nylon brush.

B - With a clean cloth impregnated with oil (special oil for sewing or knitting machines), lubricate the needle heels. In the same way, lightly lubricate the underside of the carriage.

To distribute the oil evenly place needles in position 2. Take the carriage across several times without yarn. Wipe off excess.

	PAGE NO.	POINT NO.
Accessories	2	
Alternate Needle Selection	9	1, 2
Bar Weights: Description	2	
Use	9	4,5,6
Buttonholes	24	29
Carriage: Description	1	
Movement	8	17
Cast On Combs: Description	2	
Use	9	3
Castling Off: Method 1	13	
Method 2	14,15	23-29
Castling On: Mock Rib	9,10,11	
Chain (closed edge)	23	
Waste Yarn (open edge)	20,21	8,9,10
Clamp Sockets	1	
Decreasing: Single Stitch	16	31
Fully fashioned (Italian)	19	5
Several Stitches	19	6,7
Edge Weights: Description	2	
Use	18	3
Fair Isle	28	
Fancy Stitches	25-29	
Flow Combs	1	
Graduated Scale	1	
Handles	1	
Hook and Latch Tool	2	
Increasing: Single Stitch	16	34
Fully Fashioned (Italian)	18	1
Several Stitches	18	2,3,4
Intarsia (Picture knitting)	27	
Knitting Retainer: Description	1	
Removal	32	
Re-attaching	32	
Lace	25	3
Latch Tool Ribs	20,21,22	

	PAGE NO.	POINT NO.
Maintenance	32	
Mock Rib: See Casting On		
Neck: Shaping	14,15,16	
Neck Band	16	36
Needles: Changing a Needle	32	
Movement of	6	
Parts of	6	
Needle Selector Switch: Description	1	
Use	8	18
Pulled Up Stitches	26	5
Ribs: Mock (see casting on)		
Row Counter: Cam	1	
Attaching	5	7
Setting-up	3	1,2
Re-setting	5	9
Slip Stitch	26	4
Slide Rail	1	
Stitch Formation	7	
Stitches: Dropped/Not knitting	30	
Dropped/Several rows	30	
Stitch Size Dial: Location	1	
Use	7	16
Stocking Stitch	12	16
Support for Cast on Comb(s)	1	
Table Clamps: Description	2	
Use	4	4
How to get the right stitch size	17	
Tuck Stitch	25	1-2
Undoing Rows	31	
Weaving	29	
Working Positions	6	
Yarn Clips: Description	2	
Use	10	7

SINGER*
We make it better.

SDL Limited, Grafton Way, Basingstoke, Hampshire. Tel: 0256 56291.

*A Trademark of THE SINGER COMPANY