

Superba Knitting™

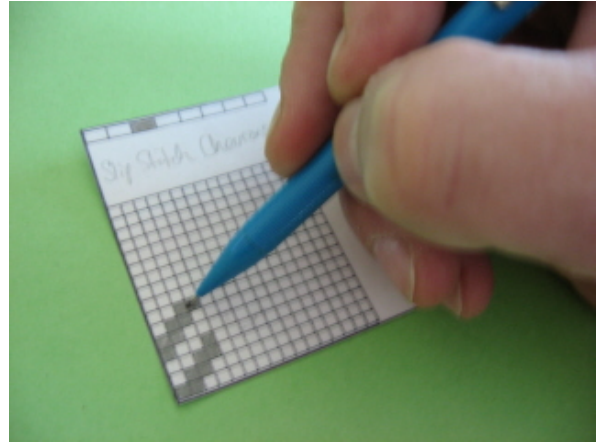

Programming Guide for the
Electronic Pressure Pad
Knitting Machine Models
Produced by
S.I.T./Groupe SUPERBA.

Guide de programmation
électronique pour les modèles
de machine à pression Pad
tricoter produite par le
SIT/Groupe SUPERBA.

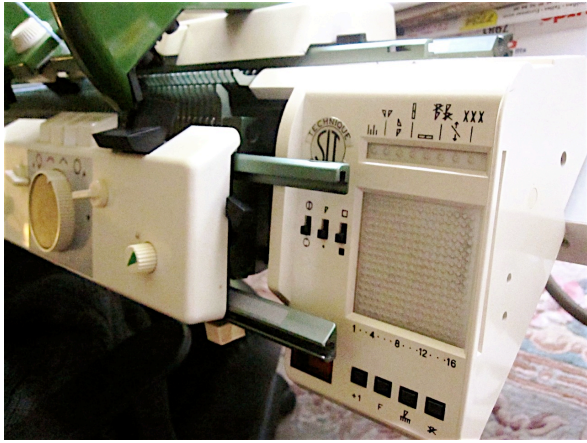

WHITE



PHILDAR

SINGER

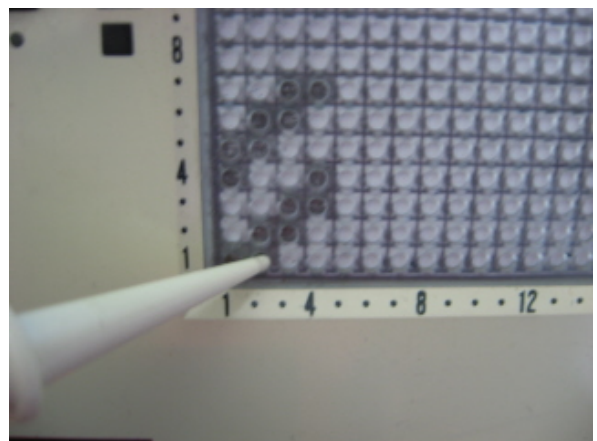
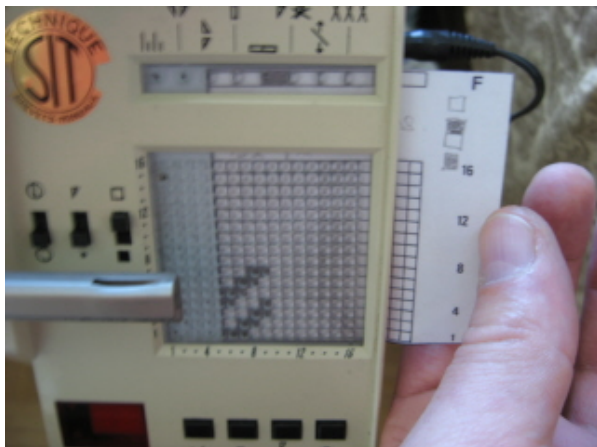

Superba Knitting™

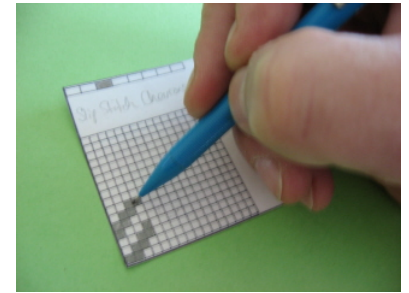
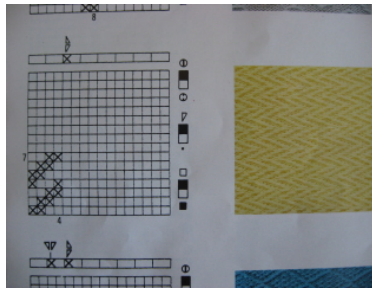

The following *instruction manual contains instructions in English for the electronic Pressure Pad stitch Programmer featured on the following brand names of home knitting machines:

- SUPERBA S47
- WHITE 1502/1402
- SINGER MEMO II
- SINGER 600/400
- SINGER MT610
- PHILDAR D115

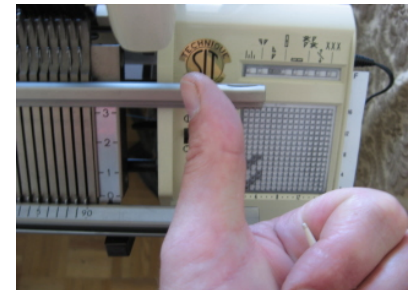
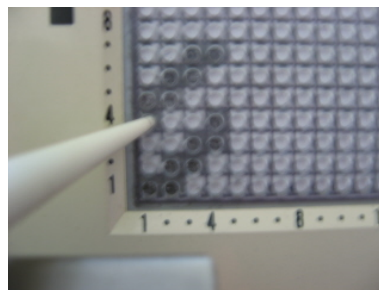
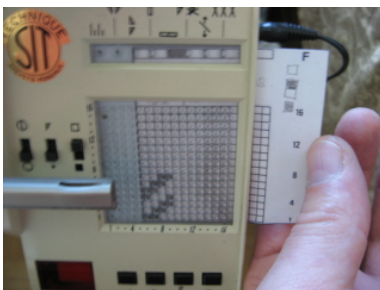

*This information is free courtesy of SUPERBA Group in Altkirch, France, which is the copyright holder for all instructional material associated with the knitting machine products formerly produced by S.I.T./Groupe SUPERBA and who have granted me permission to make this available through Superba Knitting.

SINGER*

memo II

SUMMARY

	PAGE
I Cursor and cursor stops	2
How to position the cursor stops	2-3
II How to plug in memo II	4
III How to use the basic controls.	5
On and of switch	5
Selection stop	5
Reverser	5
IV Programming sequence of memo II	6
1. The design board	6
2. How to determine the width and the height of a design	7
3. How to programme a design	8
4. How to select the particular functions	9
5. How to determine the particular functions.	10-11
6. The indicator	12
7. Various forms of programming of the designs	12-13
8. How to centralise a design	14
9. Single design in fair isle	14-16
V How to knit	17
Tuck stitches (I) Multicoloured tuck stitches	17
Slip stitches (II)	18
Fair Isle (III)	18-19
Jacquard method 1 (IV)	20
Jacquard method 2 (V)	20
Jacquard method 3 (VI)	20
Norwegian Jacquard (VII)	20-21
Weaving effect (VIII)	22-23
VI Some hints	24-25
VII What to do if	26
The carriage jams during knitting	26
You have to undo one or several rows	27
You cannot cast on	27
The needles selected for two-colour work remain in holding position 3.	28
The design is not forming	28
The edge stitches of a single design knit both yarns	28
A tuck stitch or a slip stitch is not correctly knitted	28
Explanation of the symbols	29-31

I. Cursor and cursor stops

The cursor and the cursor stops are located on the back bed, at the lefthand side of your machine. To enable you to move the cursor stops in order to unlock the cursor, loosen them by turning them clockwise (to the right).

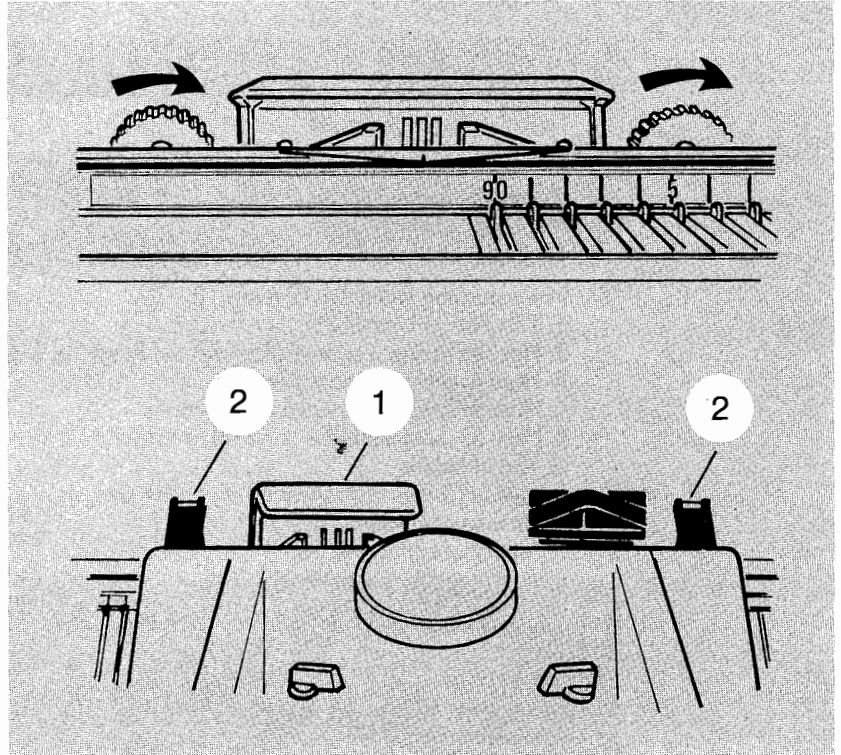

The cursor ① makes the connection between Memo II and each of the selector block feet ② on the back carriage. (The single bed machine has only one carriage and one needle bed.)

How to position the cursor stops

In order to limit the cursor stroke and the selection area, position the cursor stops correctly as follows:

- On the right-hand side, count 15 needles after the last working needle.
- Bring the centre of the right-hand cursor stop opposite to this 15th needle and lock it.
- Repeat this setting on the left-hand side.

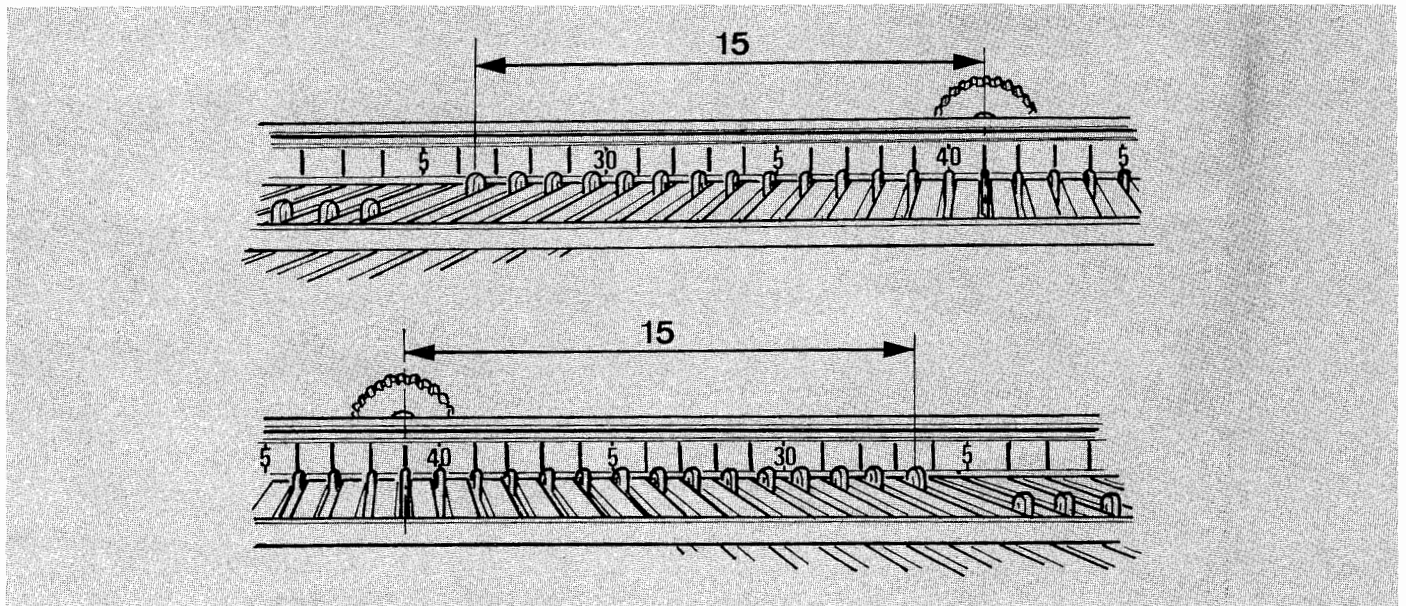

- Push the cursor against the right-hand cursor stop.

When the carriage is moved from right to left, the cursor ① is carried by the left selector block foot ②a.

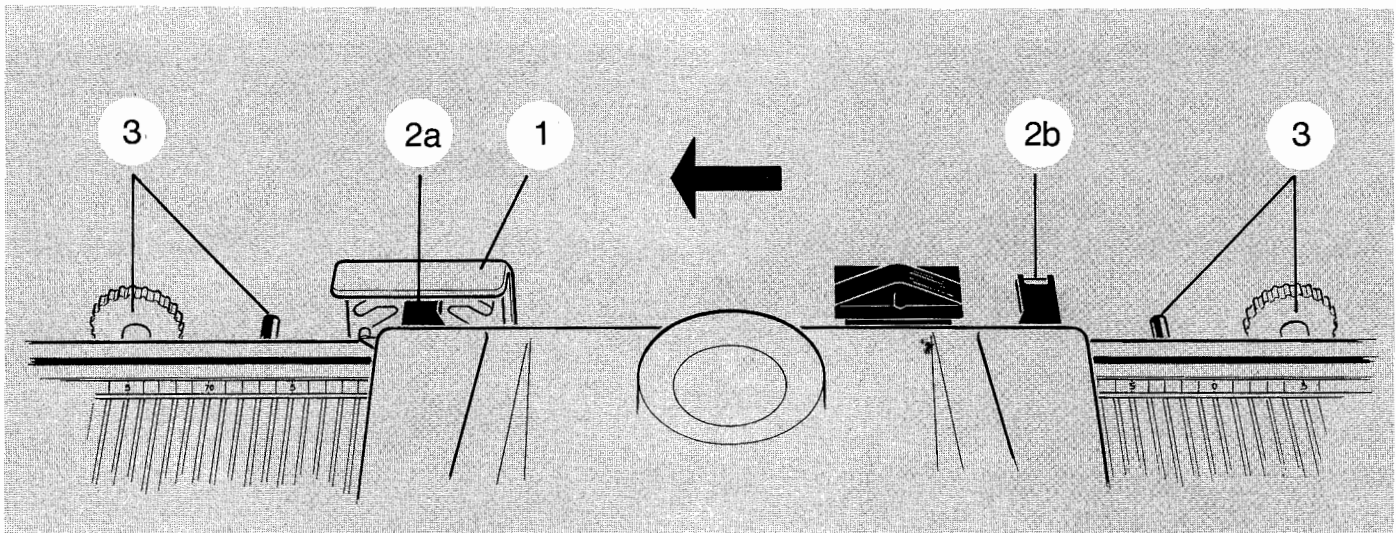

When the carriage is moved from left to right, the cursor ① is carried by the right selector block foot ②b.

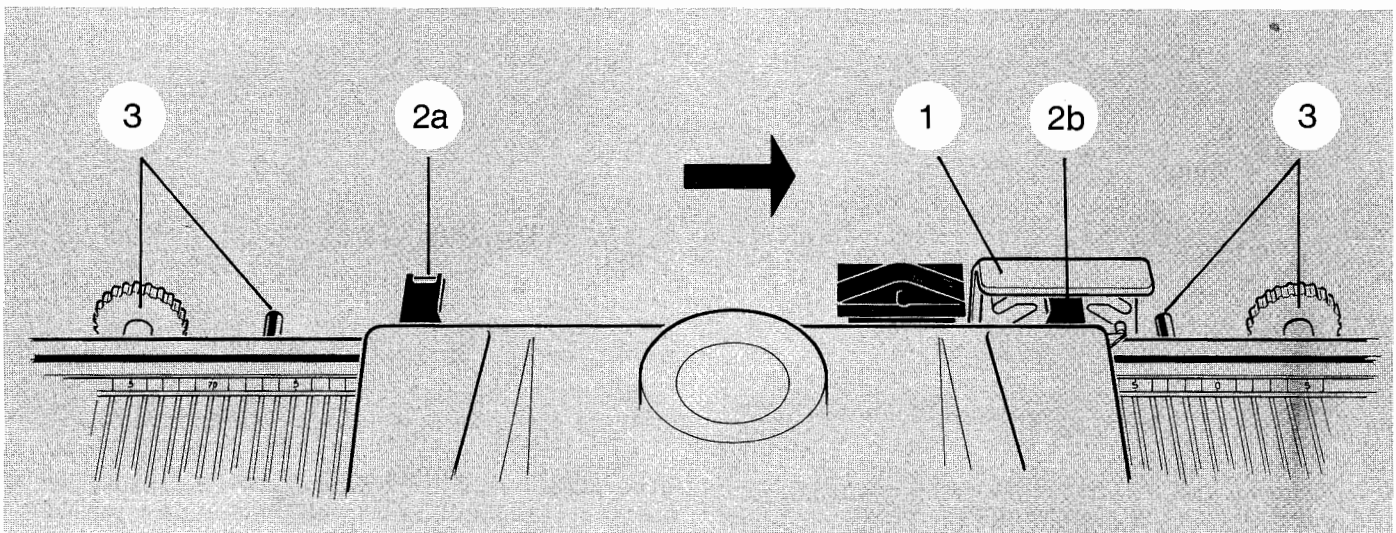

After each row, make sure that the cursor is fully disconnected from both selector block feet. The cursor rests against the stop ③.

II. How to plug in memo II

- Set the ON/OFF switch ⑥ into position OFF.
- Plug the supply unit ⑤ into the electrical outlet (220 V).
- Plug the power lead ④ into Memo II.

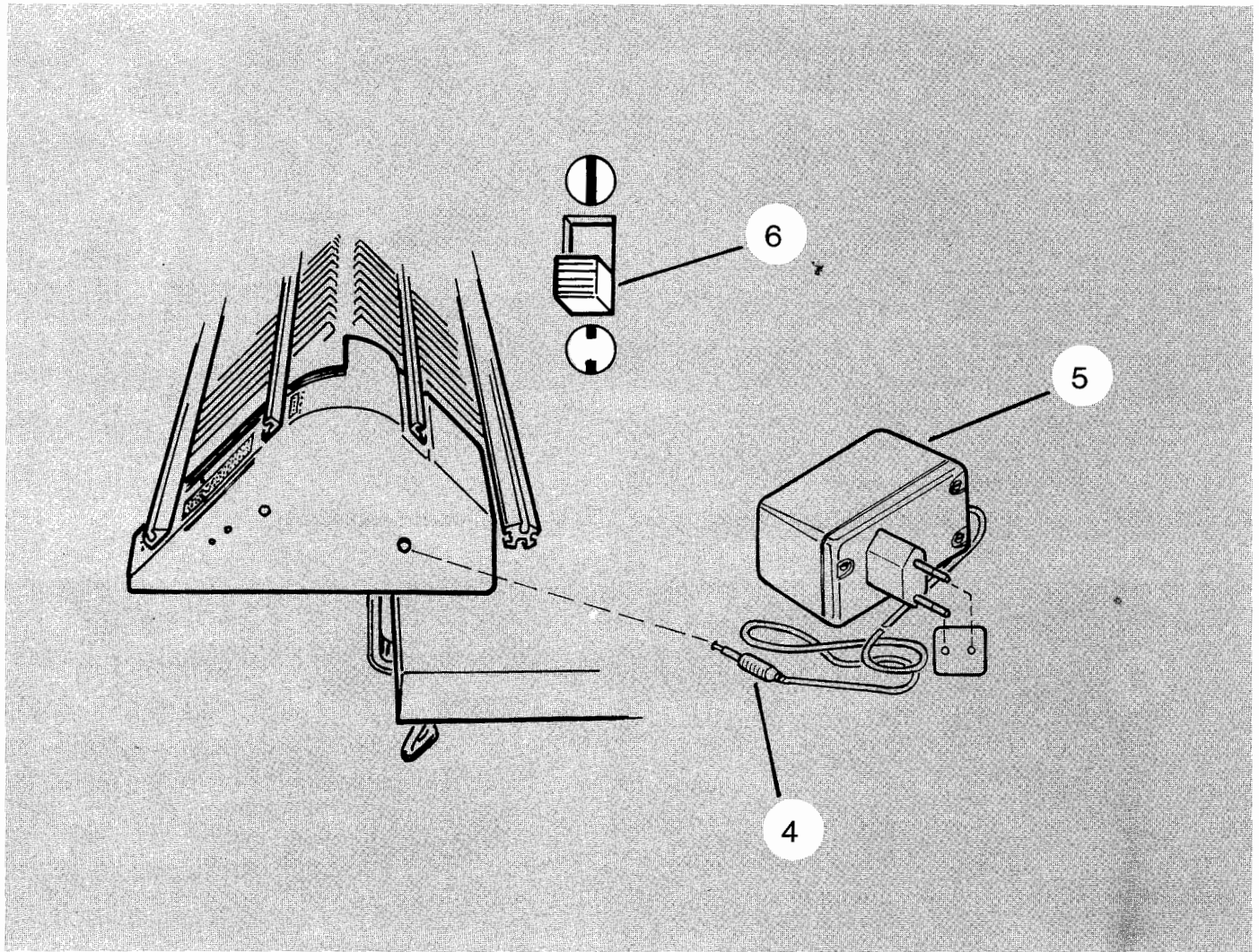

- To disconnect, set the ON/OFF switch into position OFF.
Disconnect the power lead and then the supply unit.

PLEASE NOTE: For an electrical outlet of 110/127 Volts, use a transformer.

III. How to use the basic controls

On and off switch

This is the main ON/OFF switch of Memo II.

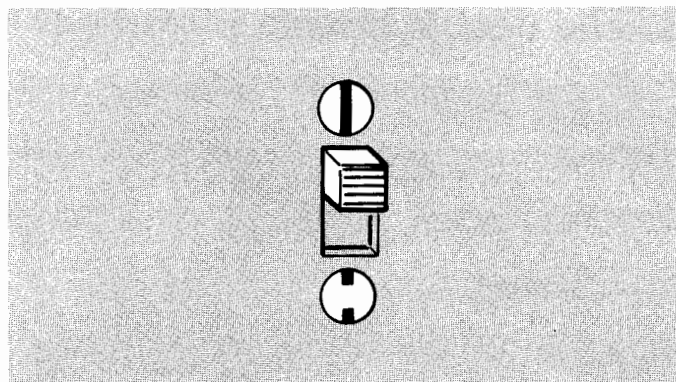

Selection stop

- When this switch is set to lower position ●, Memo II and its programme are in waiting position (no selection).
- When this switch is set to upper position ▽, Memo II is working (the needles are selected).
- The selection stop switch has to be set to lower position ● when programming Memo II.

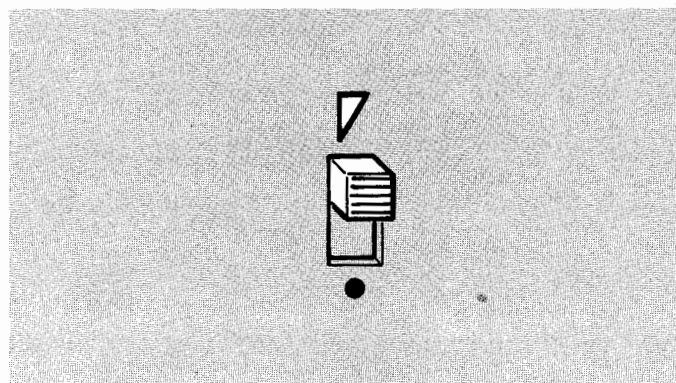

Reverser

If you knit with one yarn (tuck stitches, slip stitches, etc)

- When this switch is set to upper position □, the needles corresponding to the non-selected areas on the design board are forming stitches.
- When this switch is set to lower position ■, the needles corresponding to the selected areas on the design board are forming stitches.

If you knit with two yarns (Fair Isle)

- When this switch is set to upper position □, the needles corresponding to the non-selected areas on the design board are knitting the second colour yarn and the other needles are knitting the main yarn.
- When this switch is set to lower position ■, the needles corresponding to the selected areas on the design board are knitting the second colour yarn and the other needles are knitting the main yarn.

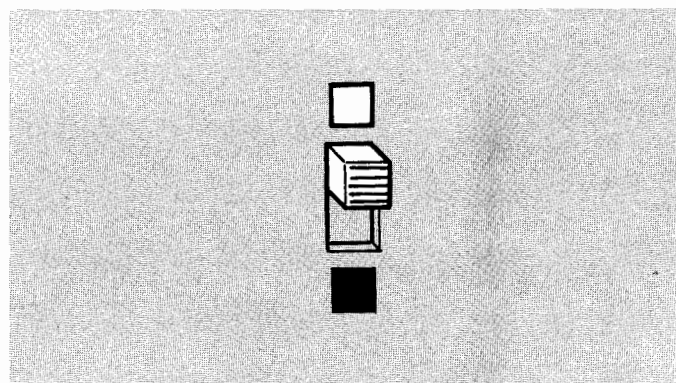

IV. Programming sequence of memo II

1. The design board

The designs are programmed on the width and the height of the board. One detail has to be observed for the choice of the largest possibility of a design.

If the design has to be programmed on more than 12 holes in the width, its height can not exceed a selection of 12 holes.

If the design has to be programmed on more than 12 holes in the height, its width can not exceed a selection of 12 holes.

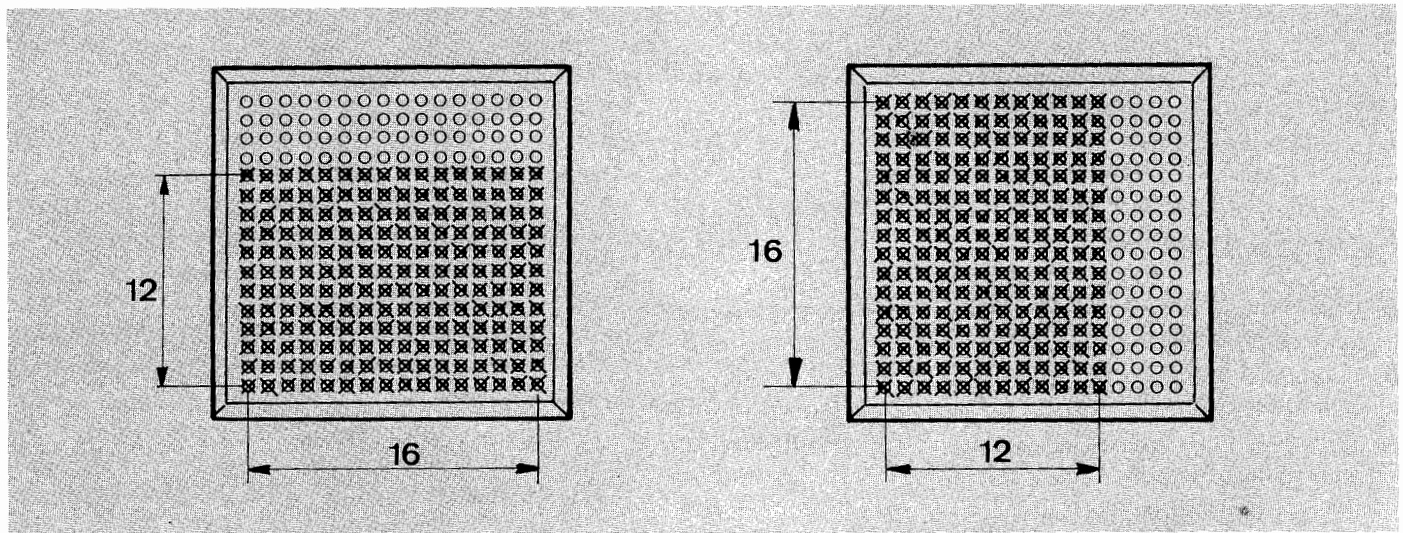

The designs in the catalogue have to be reproduced onto the blank cards provided with the machine. Make sure to cut them correctly according to your needs.

The card showing the reproduced design has to be inserted into the slit, at the side of the machine, then slides underneath the perforated design board.

PLEASE NOTE: To start with we recommend you use the design below.

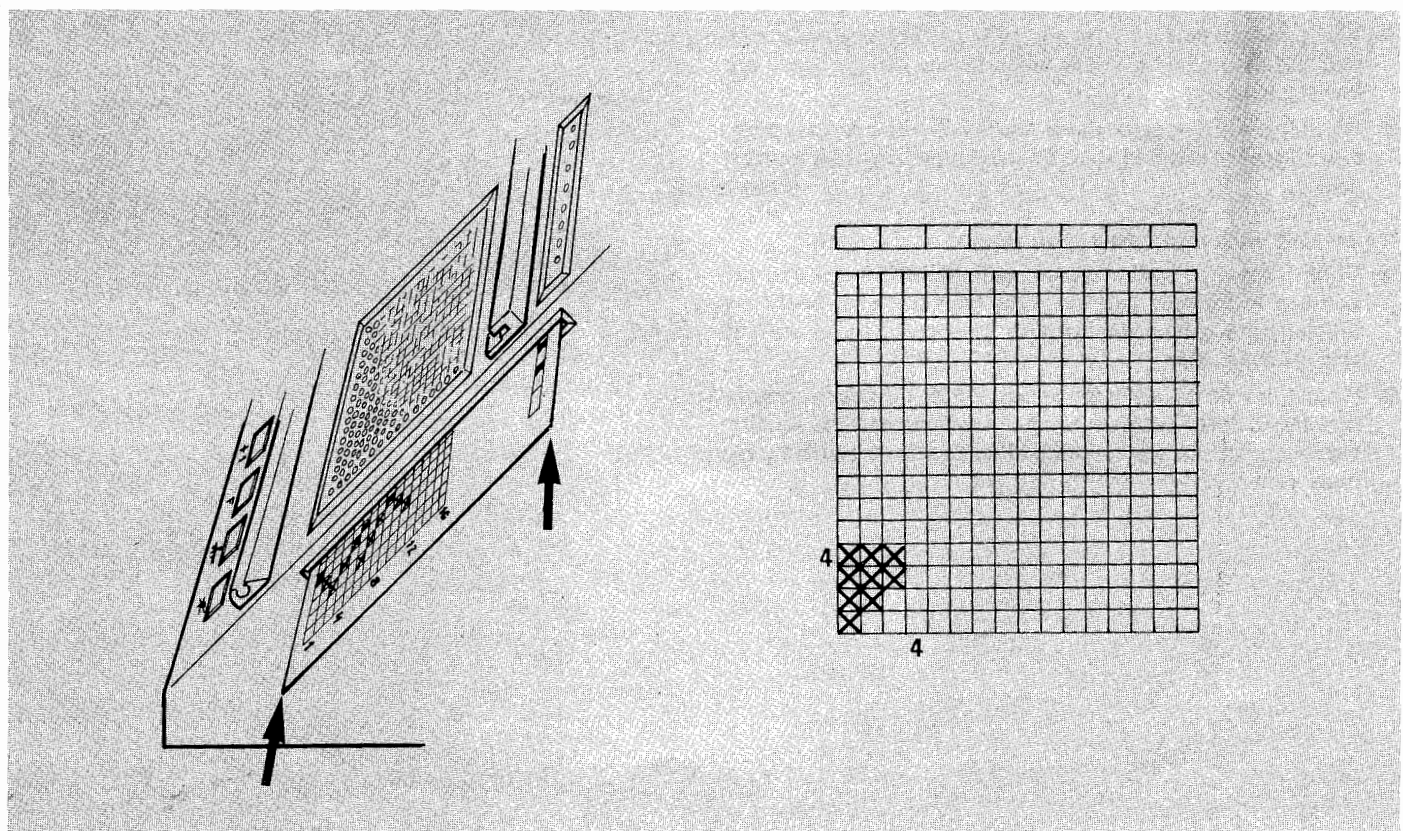

2. How to determine the width and the height of a design

A. THE WIDTH

- Press the key FUNCTIONS.
A flashing horizontal line appears on the indicator alternating with the number 1. It is now possible to determine the required width of your design.
- Press the key PATTERN LINE ADVANCE.
Numbers are now passing one after the other on the indicator. Release the pressure when the required number for the width of the design is shown (e.g. 4).

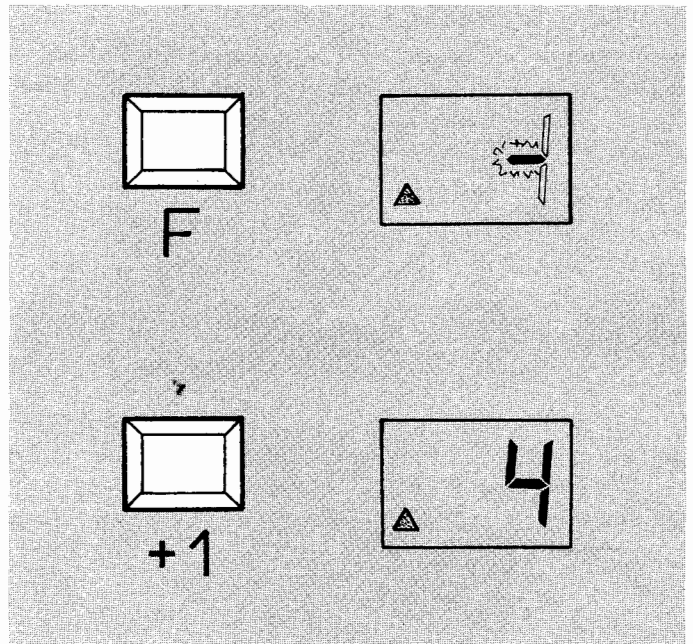

B. THE HEIGHT

- Press the key FUNCTIONS.
A flashing vertical line appears on the indicator alternating with the number 1. It is now possible to determine the required height of your design.
- Press the key PATTERN LINE ADVANCE.
Numbers are now passing one after the other on the indicator. Release the pressure when the required number for the height of the design is shown (e.g. 4).

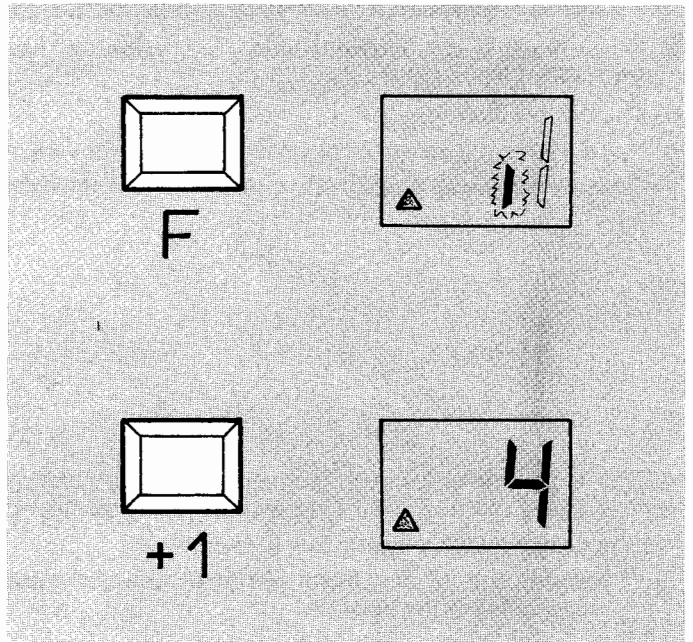

3. How to programme a design

- Press the key FUNCTIONS.
- On the indicator, two arrows light up and number 1 is flashing.
- You can now programme the first pattern line of the design.

- Introduce the tip of a pencil into the holes on the design board according to the diagram of the design.
- A bip sound is heard which confirms that the selection has been memorized.

- To programme the second pattern line, press the key PATTERN LINE ADVANCE.
- Number 2 is flashing.
- You can now programme the second pattern line of the design. Continue in this way to programme all pattern lines of the design.

NOTE: It is possible to cancel a programmed line by pressing the key CANCELLATION  in the following conditions:

- a) you must be in the programming sequence
- b) the number of the pattern line to be cancelled must be flashing on the indicator.

- After having programmed the last pattern line, press the key + 1 to make the first pattern line reappear.

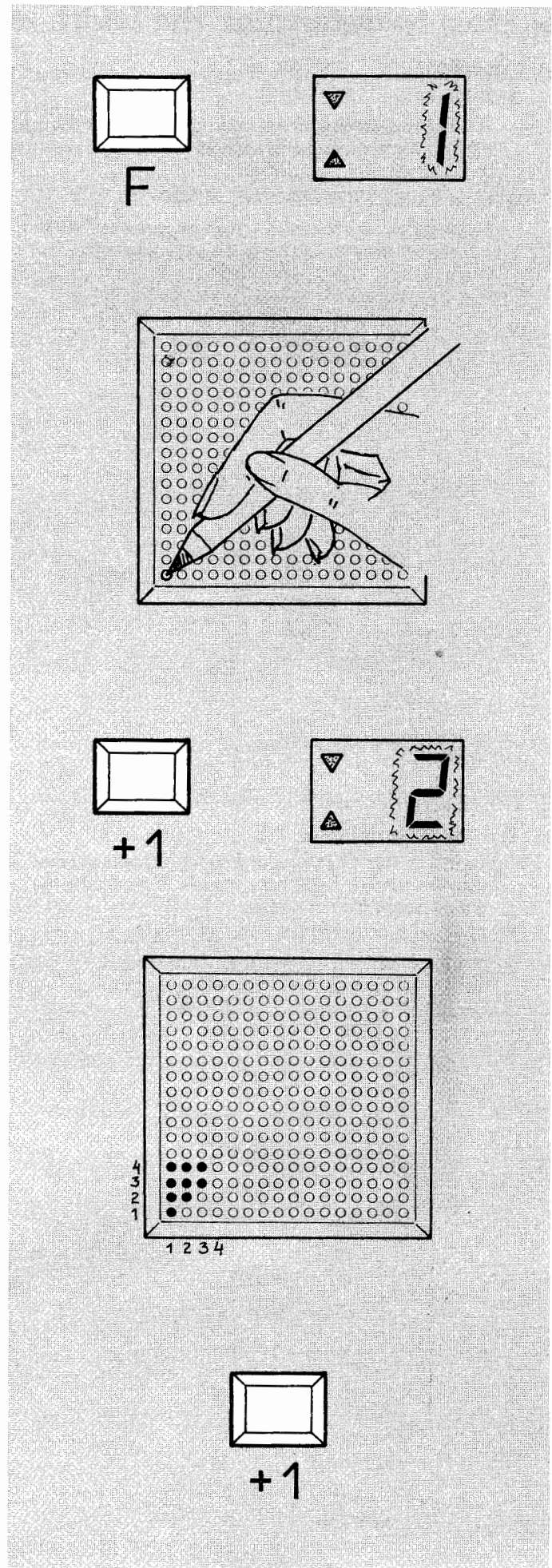

4. How to select the particular functions

- Press the key FUNCTIONS.
- The letter F appears on the indicator.
- You can programme one or several of the eight particular functions shown by symbols printed on top of the Memo II.
- To select a function, introduce the tip of a pencil into the required holes of the board corresponding to the programming of the functions.
- A bip sound is heard which confirms that the selection has been memorized.

PLEASE NOTE: It is possible to cancel a programmed function by pressing the key CANCELLATION ~~✱~~ in the following conditions:

- a) you must be in the programming sequence
- b) the letter F must appear on the indicator.

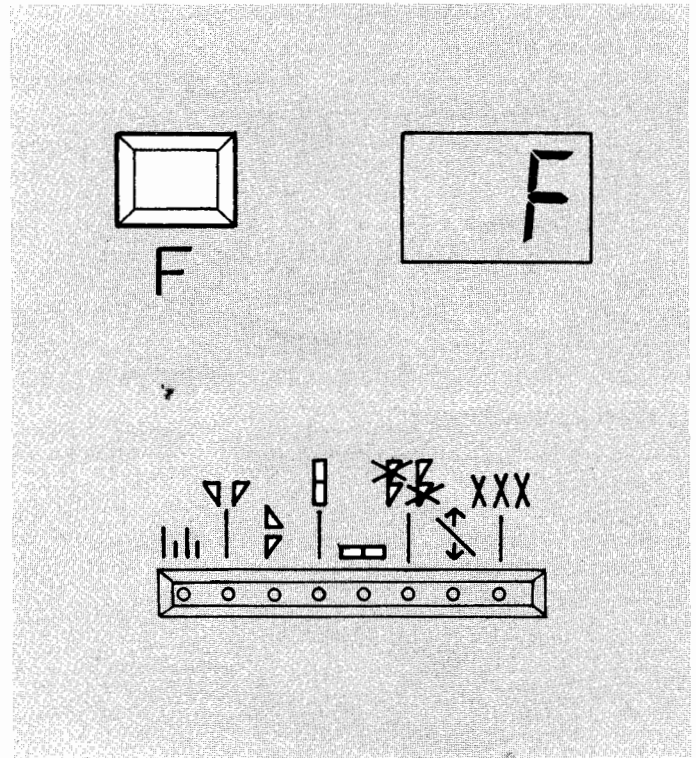

Notes:

5. How to determine the particular functions

a) Every other needle selection (bird's eye) | | | :

You automatically obtain, on the back bed, a selection of every other needle. This selection is automatically reversed on the next row.

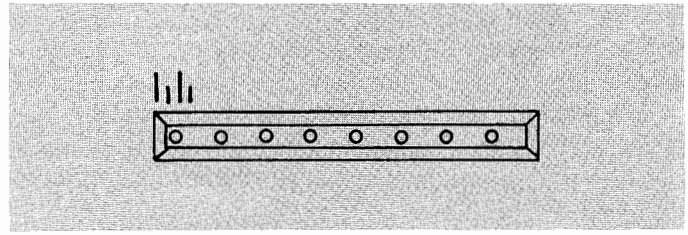

b) Horizontal symmetry:

This possibility gives you a mirror effect in the width of your selected pattern.

To guarantee a perfect symmetry of geometric designs, the first and the last column of the programmed design will not be repeated in the knitting.

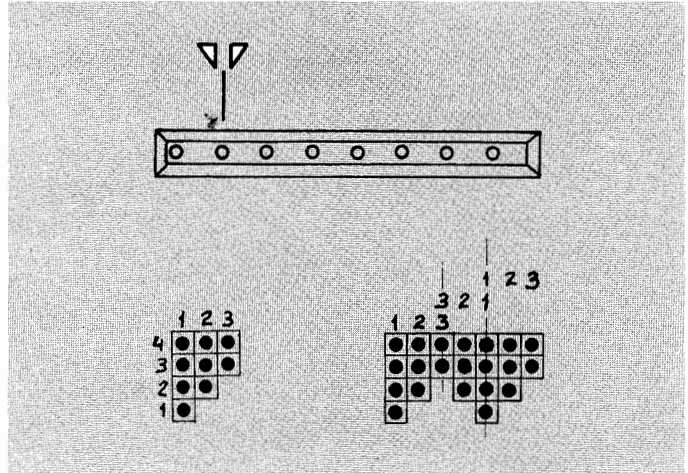

c) Vertical symmetry:

This possibility gives you a mirror effect in the height of your selected pattern.

To guarantee the perfect symmetry of geometric designs, the first and the last pattern lines of the programmed design will not be repeated in the knitting.

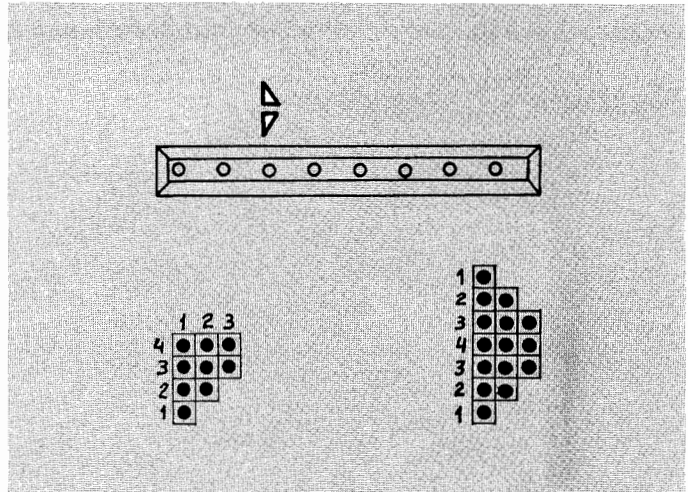

d) Twice each row:

Each programmed pattern line is selected twice in order to knit the same pattern line twice (the design is twice the height). Two rows have to be knitted before a new pattern line number appears on the indicator.

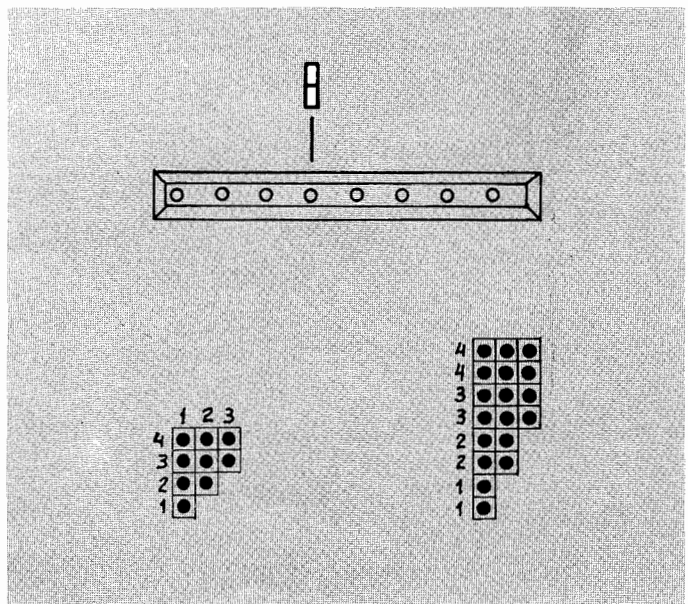

e) **Twice each stitch:**

Each programmed pattern hole corresponds to two knitted stitches (the design is twice as wide in the width).

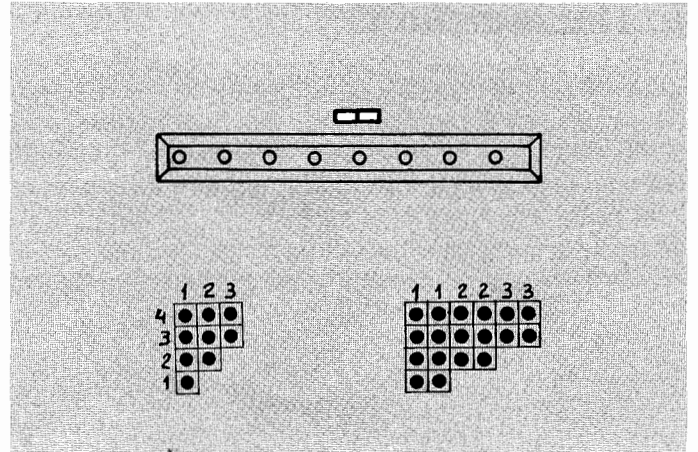

f) **Pattern space:**

The programmed designs are knitted in alternate sequence. The empty space between each pattern corresponds to the width of a design.

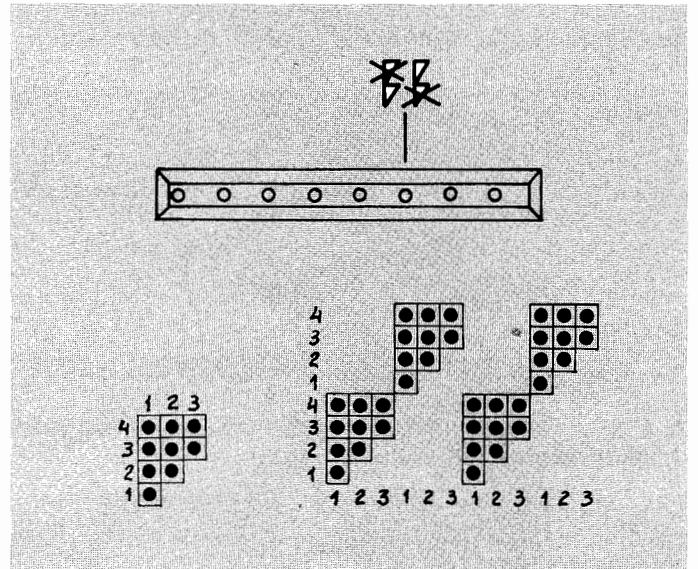

g) **Row advance stop:**

The programme is stopped, the pattern line shown on the indicator is knitted until the function ROW ADVANCE STOP is cancelled.

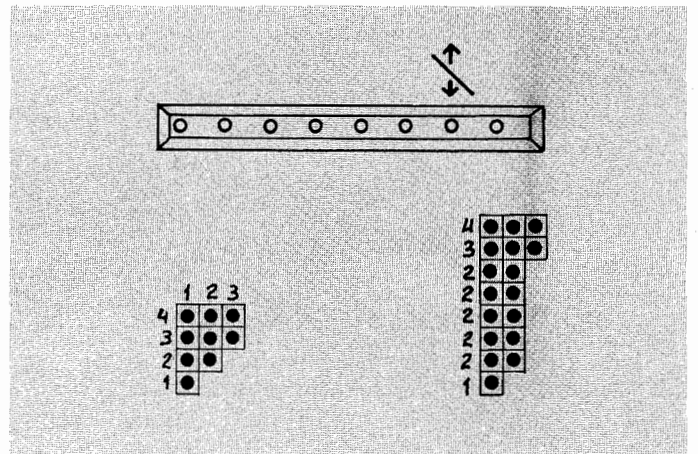

h) **Norwegian Jacquard:**

Norwegian Jacquard is automatically programmed. One pattern line is selected twice in a specific way in order to knit only one row.

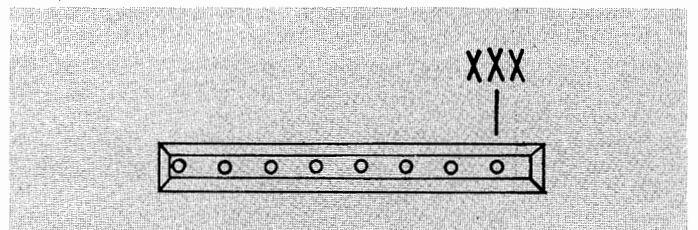

PLEASE NOTE: After having programmed the required particular functions, press the key FUNCTIONS. Number 1 must appear on the indicator. If it does not, make it appear by pressing the key PATTERN LINE ADVANCE + 1 so that you can knit the first row. To knit, set the selection stop switch to upper position ▽.

6. The indicator

On the left-hand side of the indicator, the luminous arrows indicate:
When both arrows are lit up, you are in the programming sequence of a design and one of the pattern lines is flashing.

When the arrow pointing upwards is lit up, the pattern is selected from the bottom to the top.

When the arrow pointing downwards is lit up, the pattern is selected from the top to the bottom (pattern with a vertical symmetry).

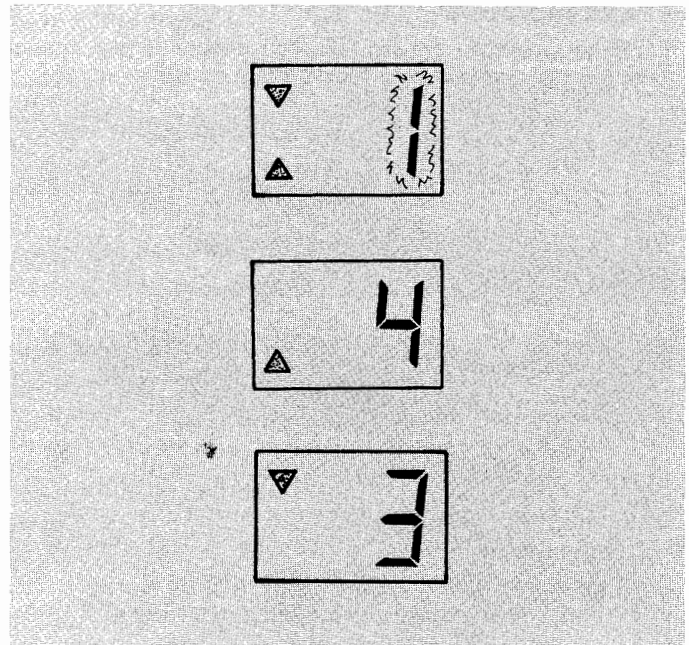

On the right-hand side of the indicator, the indications of the programming (programming sequence) or the number of the row to be knitted is shown.

7. Various forms of programming of the designs

A. If you do not use the maximum width of the design board, when programming a design, you can determine, according to your taste, a space between each pattern.

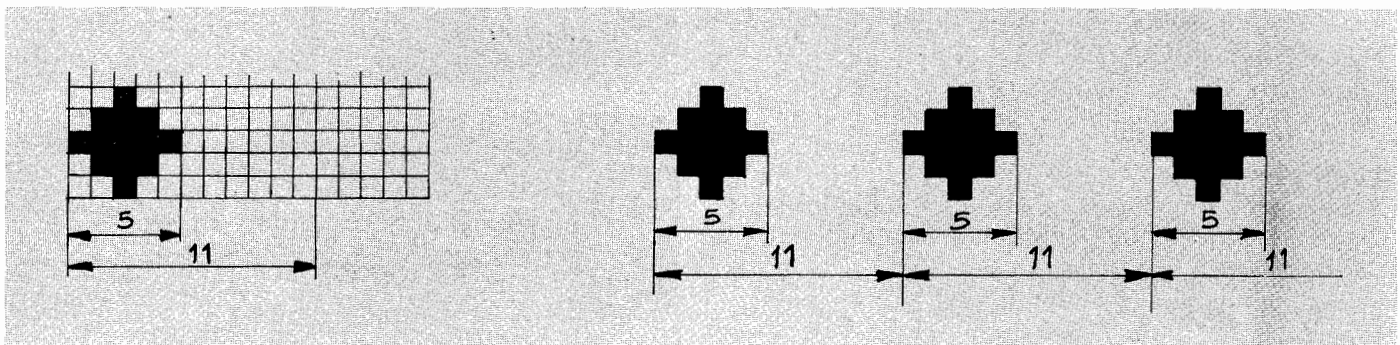

flashing: required width 11

flashing number: largest width to be programmed: 5

If you wish to leave a space between each line of design, use the switch SELECTION STOP.

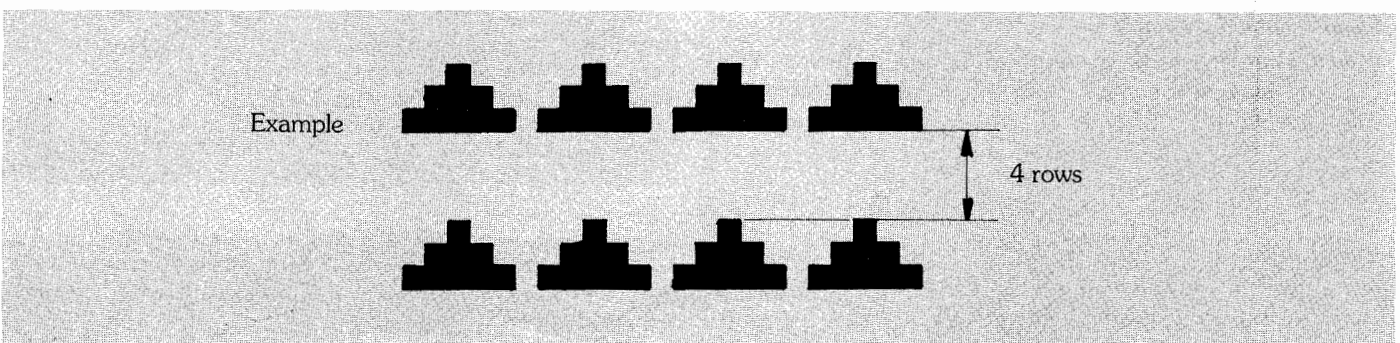

B. If your design is a decorative type and in addition non-symmetric, you have to fully programme it onto the design board.

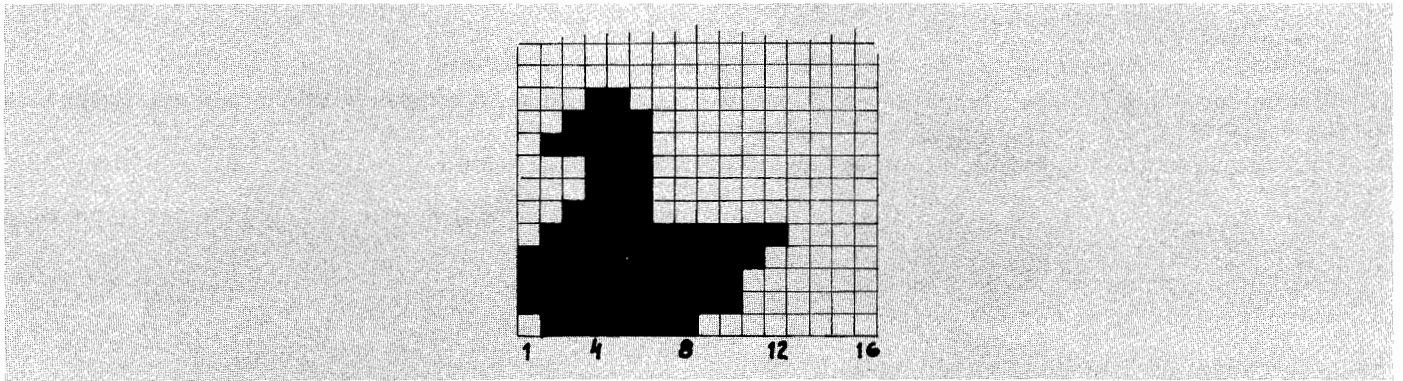

C. If you programme a design requiring a vertical symmetry ∇ , only programme half the design onto the height of the design board.

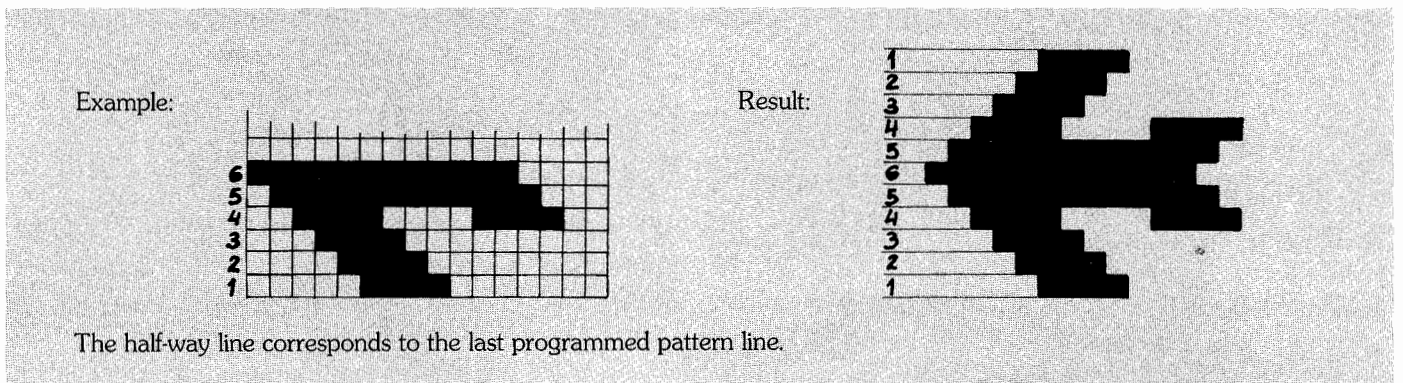

D. If you programme a design requiring a horizontal symmetry ∇ , only programme half the design onto the width of the design board.

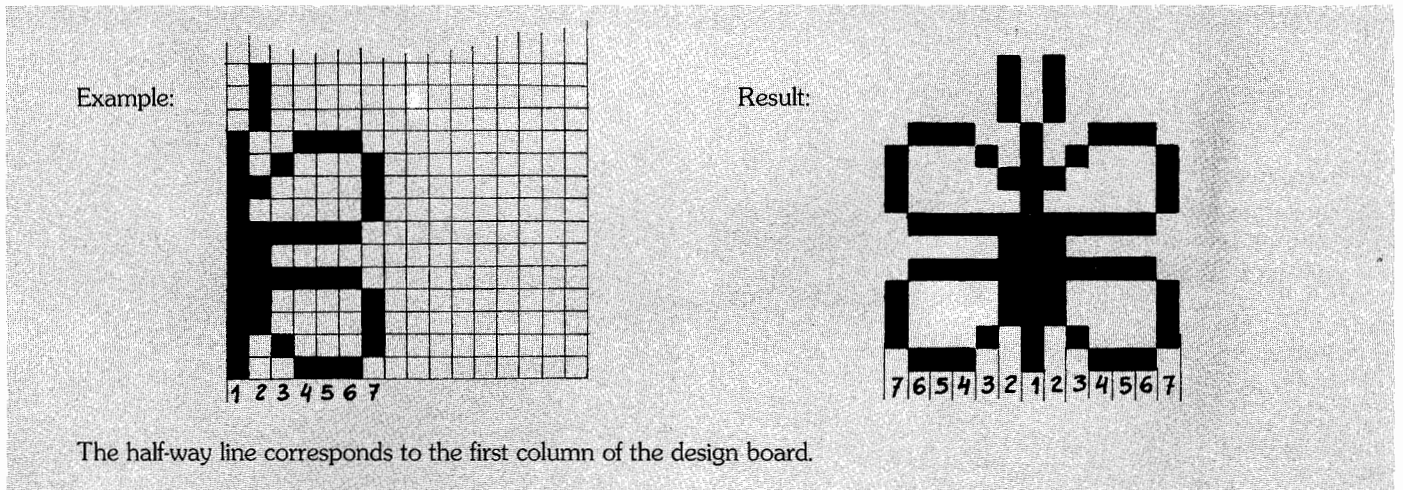

E. If you knit repeatedly a same pattern line, only programme it once and use, for this particular line, the function ROW ADVANCE STOP.

To knit the preceding and the next pattern line, press the key PATTERN LINE ADVANCE + 1.

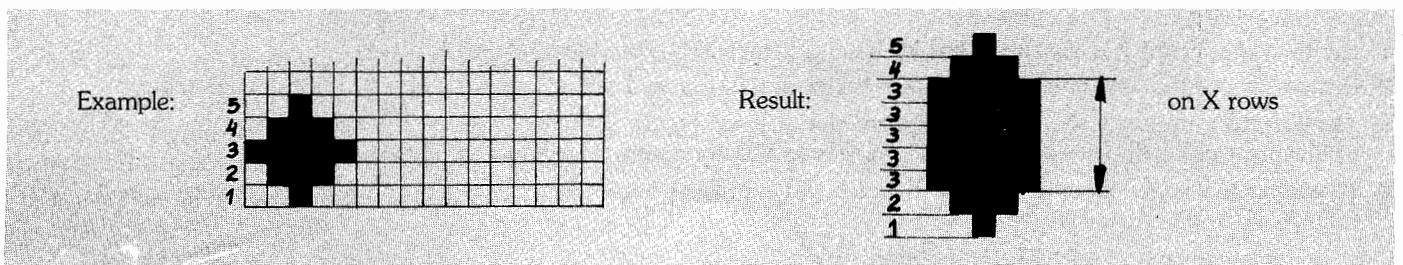

8. How to centralise a design

Before knitting, it is necessary to determine how the designs will be placed in your knitting.

It is sometimes important that the designs are well centralised to obtain a perfect symmetry between the left-hand side and the right-hand side of your garment.

- On the design board, it is always the first left-hand column which is used as a reference.

- To centralise the design, set the centre of the cursor opposite to the first needle left of 0 on the graduated scale.

- Press the key **SETTING OF A DESIGN**. Bring the cursor to the carriage side. The designs are centralised.

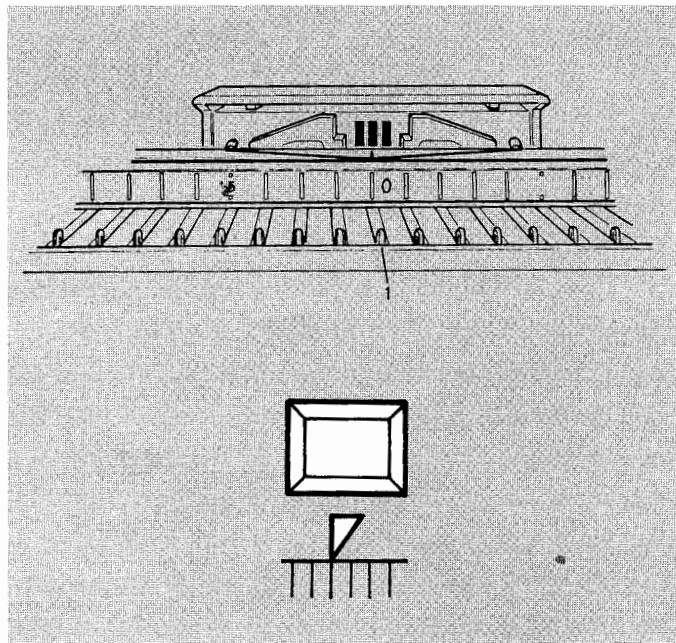

CAUTION: Each time you programme a particular function, centralise the design again by pressing the key **SETTING OF A DESIGN**.

Very important:

To centralise the designs not using a **HORIZONTAL SYMMETRY**, move the cursor towards the right-hand side of 0 on the graduated scale along half the amount of needles corresponding to the programmed design. (Multiply by 2 if you use the function **TWICE EACH STITCH**).

Now, press the key **SETTING OF A DESIGN**.

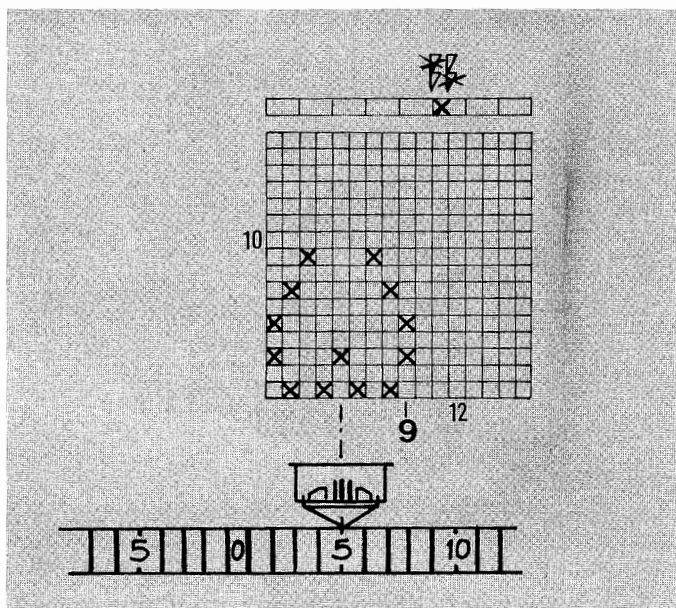

9. Single design in Fair Isle

- On the design board, it is always the first left-hand column which is used as a reference.
- Remember that the programmed designs are knitted in the reverse direction as you see the purl side of your knitting.
- As the cursor transmits the necessary information to continuously knit the programmed Fair Isle patterns, it will be easy to limit the stroke of the cursor by using the cursor stops in order to only programme one design.
- To guarantee a larger space between each design and in order to avoid the knitting of the next design, we recommend:

1) to programme the function **PATTERN SPACE** 

2) Even if your design does not require a pattern space, select the largest possible height and width for a design (12, 16).

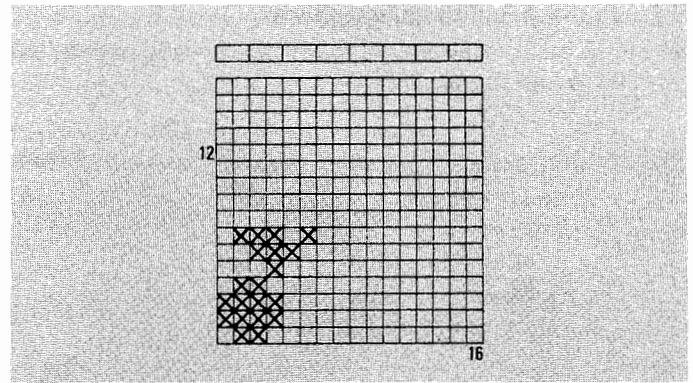

3) If you use the function VERTICAL SYMMETRY, only programme your design from the second line of the design board.

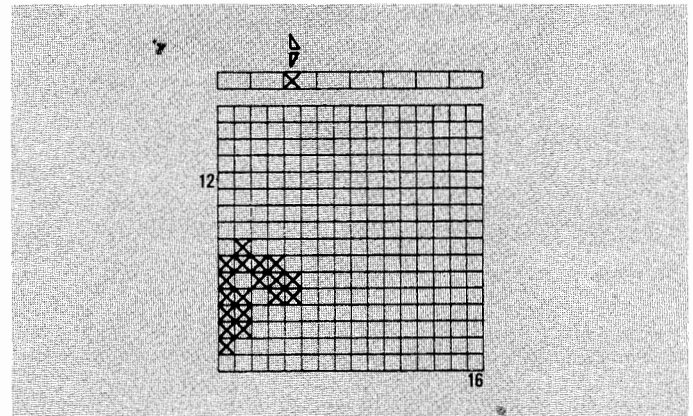

4) A single design should always be knitted with reverser ■. If you want to reverse the colours, make sure to change the yarns in the yarn guides.

a) **Decorative type of design:**

- Set the cursor at the place of your choice. It will correspond to the first left-hand column.

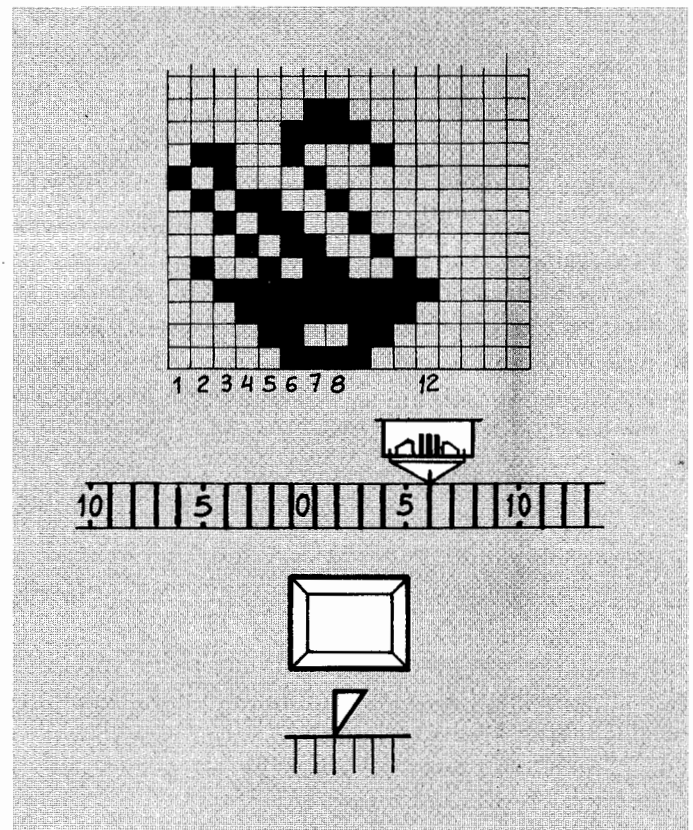

- Press the key SETTING OF A DESIGN.

- Move the cursor 5 needles towards the right-hand side in order to guarantee a space.
- Hold the cursor, bring the right-hand stop against it and lock the stop.
- Move the cursor towards the left-hand side along the amount of needles corresponding to the programmed design. (Multiply by 2 if you use the function TWICE EACH STITCH). Then move the cursor along 5 extra needles and lock the left-hand stop.
- Move the cursor to the carriage side.

b) **Design with horizontal symmetry:**

- Set the cursor at the place of your choice. It will correspond to the first left-hand column on the design board, consequently the centre of the design.

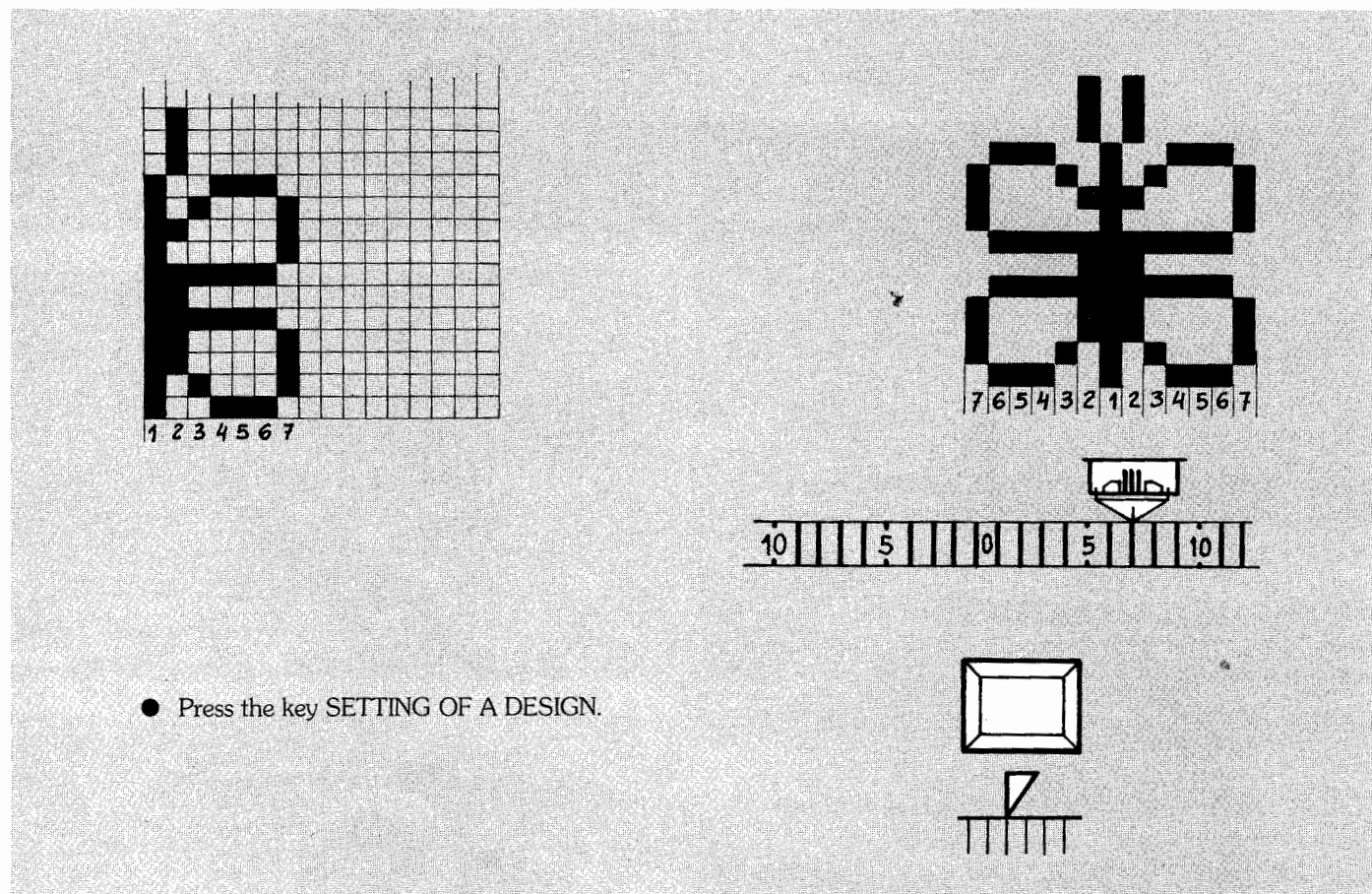

- Press the key **SETTING OF A DESIGN**.

- Move the cursor towards the right-hand side along the amount of needles corresponding to the programmed design. (Multiply by 2 if you use the function **TWICE EACH STITCH**), plus move along 5 extra needles.
- Hold the cursor, bring the right-hand stop against it and lock the stop.
- Repeat the same operation on the left-hand side in relation to the setting of the design.
- Before knitting, press the key **PATTERN LINE ADVANCE** only once if you have not programmed the first line. On the indicator, line 2 is shown (first pattern line).
- Knit.

You can change the effect of a programmed design by adding function  (Bird's Eye).

The Bird's Eye effect  can follow the programmed design or be used with it, thus overlapping it and giving it a Bird's Eye background.

We recommend that you follow these instructions carefully in order to obtain the desired effect.

When centralizing the design:

- Move the cursor from the carriage side i.e. the side where you will start your design. The centre of the cursor exactly opposite the chosen needle.
Then press the key **SETTING OF A DESIGN**.
- To obtain a different effect, move the cursor to the side opposite to the carriage then come back to set the centre of the cursor opposite to the chosen needle i.e. centre of design.
Then press the key **SETTING OF A DESIGN**.

V. How to knit

CAUTION: In the following instructions, the sections printed onto a grey background correspond to the double bed machine. The picture showing two carriages  will also specify the use of both needle beds.

1. The patterns are classified per type and are represented by a roman figure:

Tuck stitches I

Slip stitches II

Fair Isle III

Jacquard method 1 IV

Jacquard method 2 V

Jacquard method 3 VI

Norwegian Jacquard VII

Weaving effect VIII

2. At the beginning of the catalogue, the various settings of the machine and the carriages which are necessary to knit the pattern are illustrated by means of symbols.

Tuck stitches (I)

- Cast-on to your choice. At the last row, all stitches must be on the back bed and your carriage is on the right-hand side.
- Set the carriage as illustrated.
- Programme Memo II and knit.

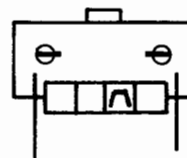

Multicoloured tuck stitch

- Cast-on to your choice. At the last row, your carriage is on the left-hand side and all stitches are on the back bed. It will make threading of the other colour easier.
- To make it easier, you can use the Jacquard claw.
- Setting of the carriage:
- Programme Memo II.
- Knit changing colour every 2 or 4 rows.

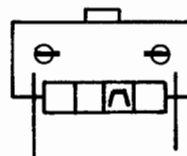

Slip stitches (II)

- Cast-on to your choice. At the last row, all stitches must be on the back bed and your carriage is on the right-hand side.
- Set the carriage as illustrated.
- Programme Memo II and knit.

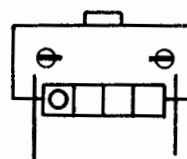

CAUTION FOR FAIR ISLE III, JACQUARDS IV, V AND VI

When using the above methods, never bring needles into holding position 3. They would be automatically recalled in working position 1 by the Jacquard key.

See "SOME HINTS", page 24, chapter 4.

Fair Isle (III)

- Cast-on to your choice. At the last row, all stitches must be on the back bed and your carriage is on the right-hand side.

SINGLE BED

Thread the second yarn, pass it into the second guide on the knitting retainer, then push the two buttons B towards the outside. Fasten the yarn at the left-hand yarn clip. Release the yarn as soon as the carriage passed the working needles.

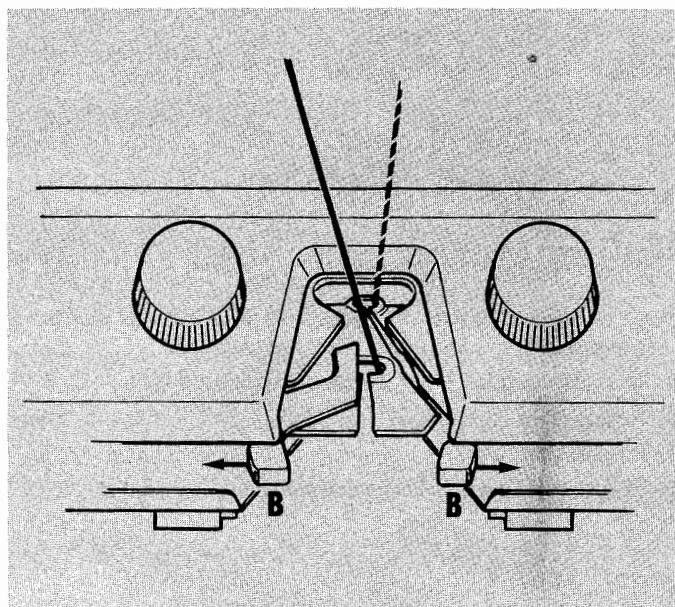

 **DOUBLE BED**

The second yarn guide is composed of:

- 1) The body (A)
- 2) The fasteners (B) to attach it to the carriage.
- 3) The needle raisers (C) which can be unlocked and turned.
- 4) Two slots (D and E) allow the passage of the two yarns. Slot D corresponds to the main yarn and slot E corresponds to the second yarn.

- Bring the front bed into lower position.
- Take the second yarn guide. Both white fasteners must show towards the centre.
- Fit the two metal fingers into the space at each side of the brushes on the back carriage.
- Hold the second yarn guide in place and lock it by sliding both white fasteners towards the outside.
- Thread the second yarn and pass it into the second yarn guide.
- Fasten the end of the yarn on the left-hand yarn clip.

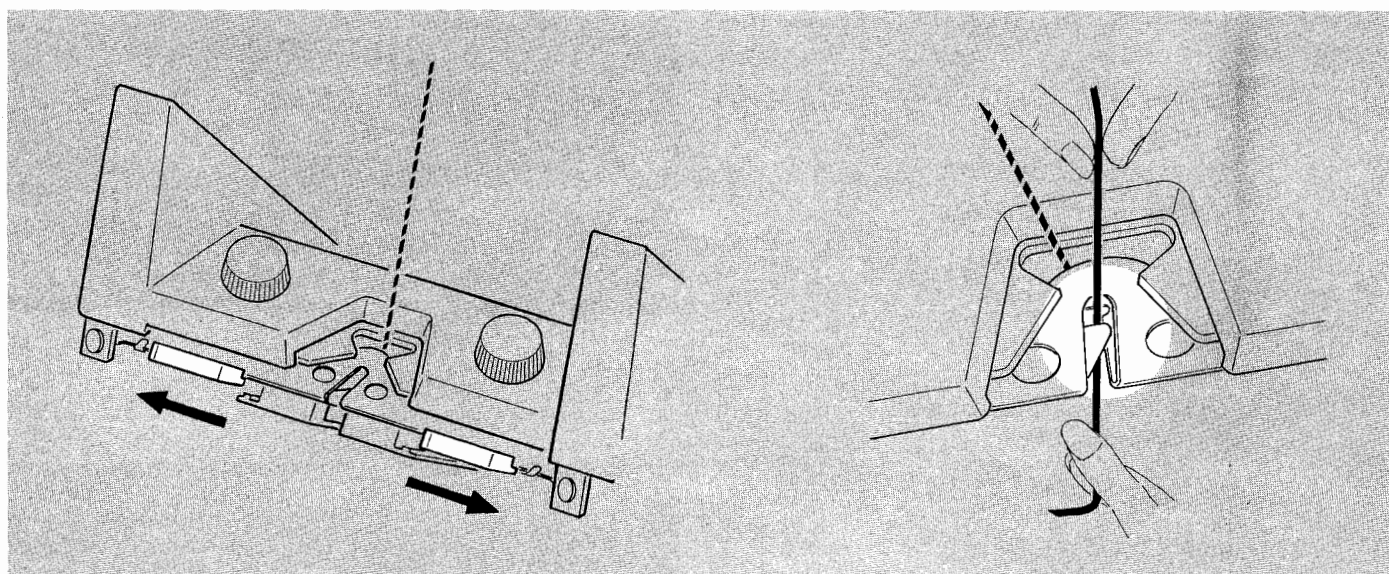
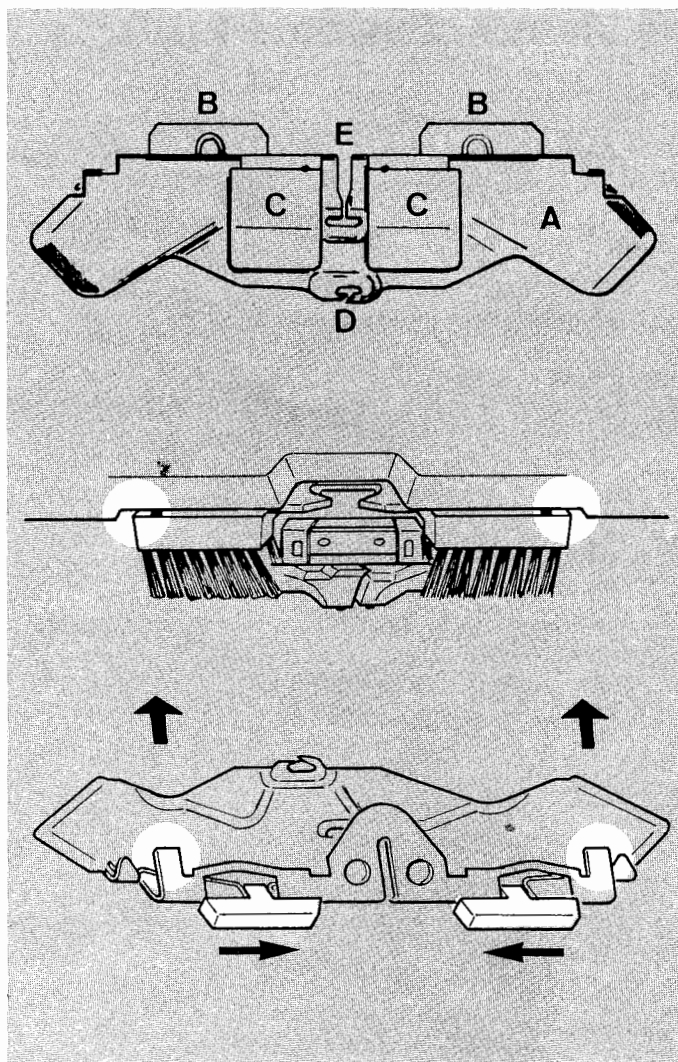

- Set the carriage as illustrated.
- Programme Memo II and knit.

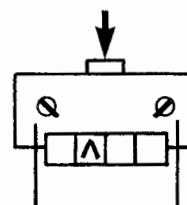

Jacquard method 1 (IV)

- Cast-on to your choice. At the last row, you must be in close rib with an even number of needles on each needle bed. The carriages are on the right-hand side.
- Attach the second yarn guide.
- Thread the second yarn and fasten the end at the left-hand yarn clip.
- Set the carriages as illustrated.
- Programme Memo II and knit.

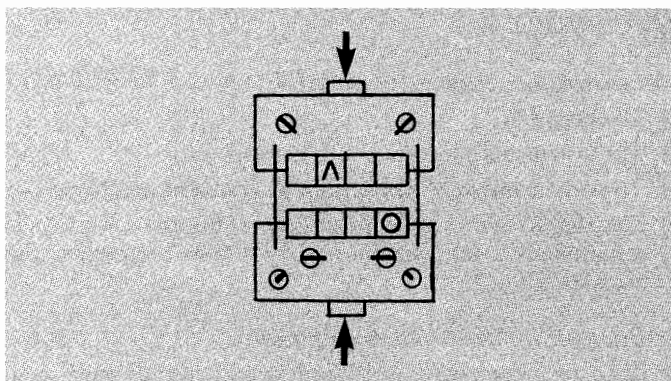

Jacquard method 2 (V)

This method is similar to the previous one, but the settings of the carriages are different.

- Set the carriages as illustrated.
- Programme Memo II and knit.

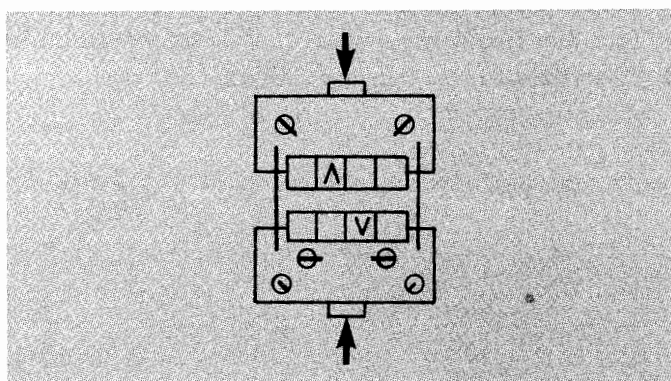

Jacquard method 3 (VI)

This method is similar to method 1, but the settings of the carriages are different.

- Set the carriages as illustrated.
- Programme Memo II and knit.

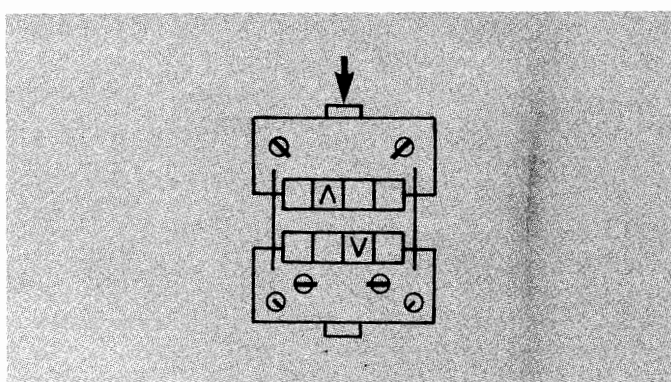

Norwegian Jacquard (VII)

- Select an even number of needles on each needle bed.
- Cast-on in close rib and knit the number of rows required before starting to knit Jacquard.
- Finish with carriages at the right-hand side.
- Insert the Jacquard claw at the left-hand side of the back carriage, signs  and stud on top of claw, into the fixing spring located between the left-hand brush of the carriage. Insertion is easier after unlocking and lifting the carriage. Remember to lock it again.

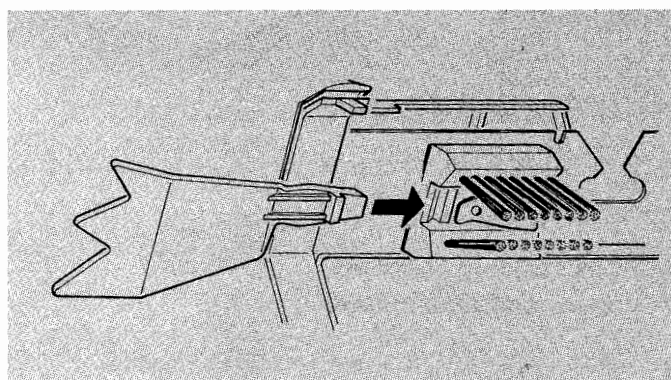

- Set the carriages as illustrated.
- Programme Memo II. (F: XXX)
- Knit one row with the main yarn. The carriages are now on the left-hand side.
- Unthread the yarn guide making sure to pass the yarn under the brushes to avoid it catching on them.
- Place the yarn into the back notch of the Jacquard claw, opposite to the symbol \uparrow representing the main yarn threaded in the right-hand side of the tension unit.
- Push the Jacquard claw forward.
- Thread the left-hand side of the tension unit with the second yarn making sure to pass it **under** the main yarn, then thread into the yarn guide.
- Fasten the end of the yarn at the left-hand yarn clip.
- Knit two rows.
- Unthread the yarn guide making sure to pass the yarn under the brushes to avoid it catching on them.
- Place the yarn into the front notch of the Jacquard claw, opposite to the symbol \downarrow representing the second yarn threaded in the left-hand side of the tension unit.
- Push the Jacquard claw backwards.
- Unhook the main yarn, pull it towards the front and hold it in front of the opening of the carriage, above the yarn guide (the yarn passes in front of the right-hand brush). When moving the carriages towards the right-hand side, stretch the yarn backwards and towards the left-hand side. It will thread itself automatically.
- Knit two rows.
- Unthread the yarn guide making sure you pass the yarn under the brushes to avoid it catching on them.
- Place the yarn into the back notch of the Jacquard claw, opposite to the symbol \uparrow .
- Push the Jacquard claw forward.
- Unhook the second yarn, pull it forward, etc. ... (see above).
- Knit two rows.*
- Repeat from* to*

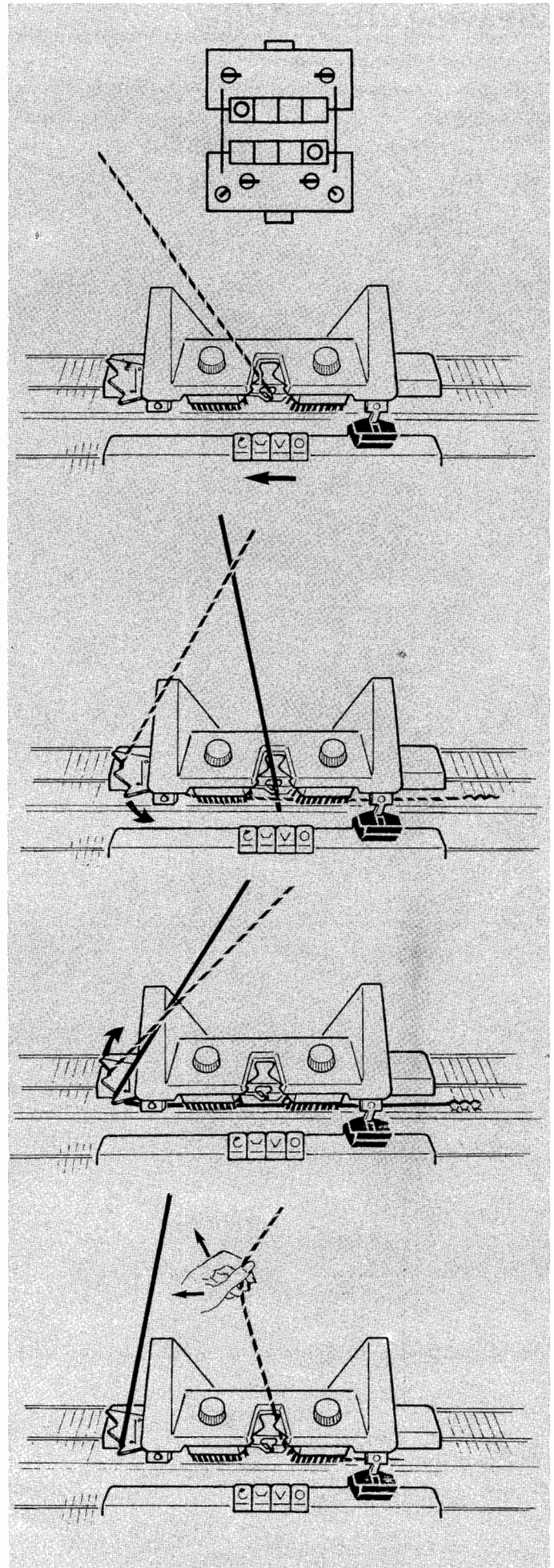

Weaving effect (VIII)

Weaving effect allows you to use heavy yarns.

- Cast-on to your choice. At the last row, all stitches must be on the back bed and your carriage on the right-hand side.
- Use the fine yarn to knit. It must be threaded in the left-hand side of the tension unit.
- Thread the heavy yarn in the right-hand side of the tension unit and fasten it on the right-hand yarn clip.

SINGLE BED MACHINE

- Swing the weaving effect device upwards as illustrated below.

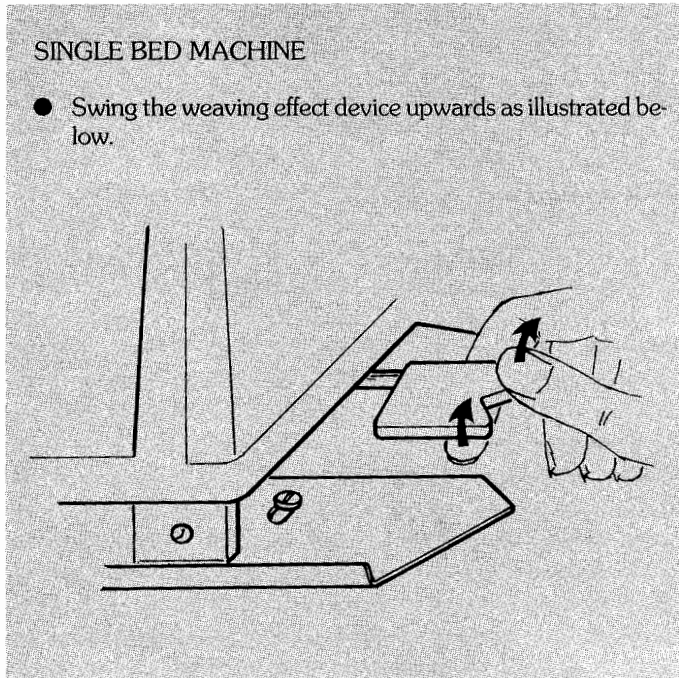

DOUBLE BED MACHINE

- Unlock the back carriage and lift it to insert the weaving brushes. The round brushes face you. One brush is at the right-hand side and the other is at the left-hand side.

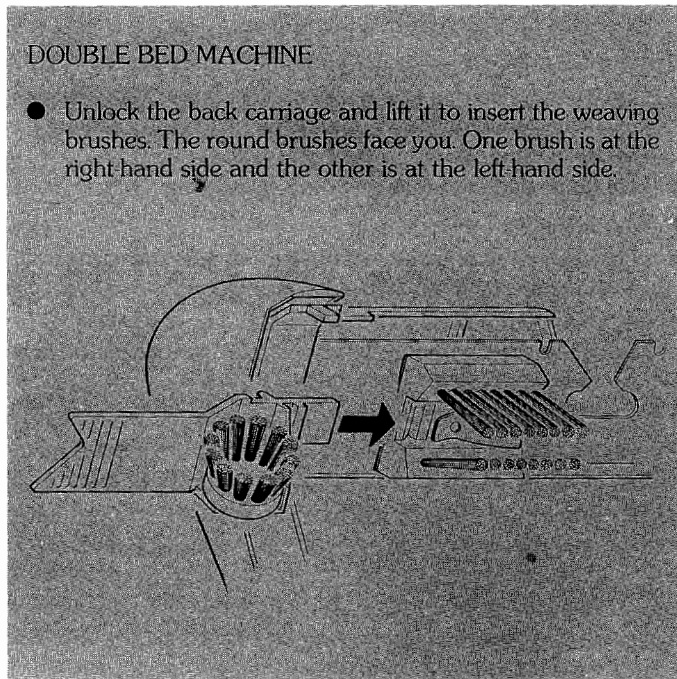

- The heavy yarn must always be ahead of the main yarn when you knit.
- Set the carriage as illustrated.

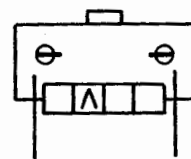

POSITION OF THE CURSOR STOPS

- Set the centre of the cursor opposite to the end needle.

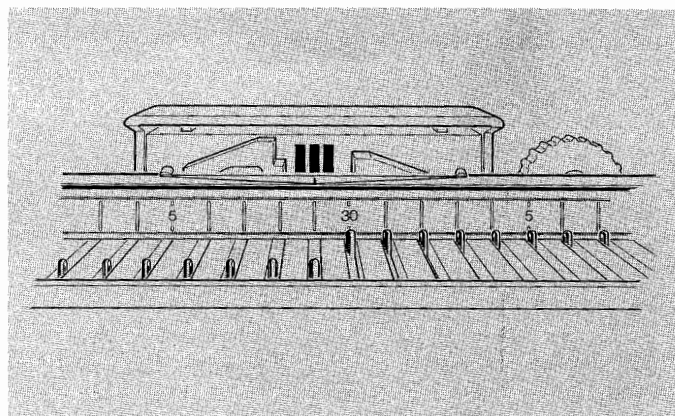

- Programme Memo II.
- During knitting, when the middle of the carriage reaches the last working needle, pull the heavy yarn towards you. Move the carriage further to finish the row. Release the heavy yarn.

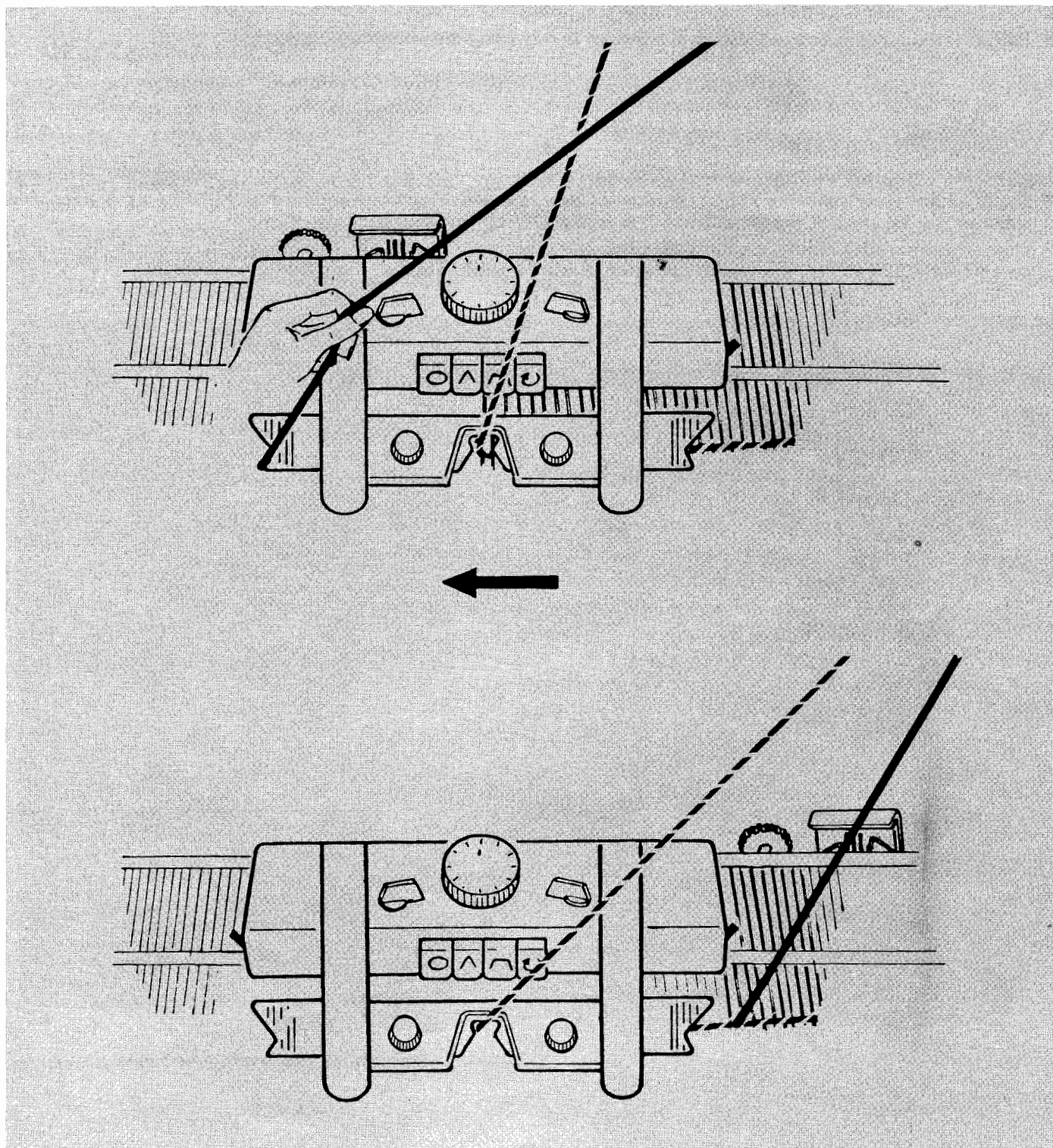

- Continue to knit making sure you remove the heavy yarn in time. To obtain perfect edges, move the second needle into position 2 on each row, at the carriage side.

If you have forgotten to remove the yarn:

- Lower the front bed and pull the yarn towards you.
- Replace the front bed in upper position.

On single bed machine pull the yarn behind and under the knitting retainer.

VI. Some hints

1. CURSOR AND CURSOR STOPS:

- Make sure that the carriage is moved far enough in order that the cursor is always carried by the correct selector block foot.
- When using the motor-drive, correctly position the stroke limits to obtain the above result.
- Before knitting, make sure that the cursor is on the same side as the carriage.
- Reposition the cursor and cursor stops when increasing or decreasing and when making a neckline.

2. INTERRUPTION OF KNITTING:

- Should you leave your knitting for a short time, leave the main switch in position ON **Ⓚ**. You may resume knitting as required.
- Should you leave your knitting for a longer period, take a note of the pattern line shown on the indicator as well as the direction of the arrow seen on the indicator. Set the main switch in position OFF **Ⓚ** and unplug the power lead.
- When resuming knitting, re-plug the power lead, set the main switch in position ON **Ⓚ**. Reprogramme Memo II and by means of the key PATTERN LINE ADVANCE, reset the programme onto the required pattern line in the correct direction.

3. Always remove the second yarn guide before moving the carriage across empty needles.

4. When knitting in Fair Isle or Jacquard, never bring needles into holding position 3 as they would be automatically recalled to position 1 by the Jacquard key.

Therefore, when making a neckline in two-colour work, proceed according to one of the four following methods:

- a) With the double ended eyelet needle, thread an auxiliary yarn through the stitches to be removed.
- b) Knit a few rows with a waste yarn, break it and remove the knitting.
- c) Take the stitches to be removed onto a hand knitting needle or a stitch holder.
- d) Transfer the back bed stitches onto the opposite front bed needles.

When knitting in Jacquard, use either method a, b or c.

- To knit the second side of the neckline, make sure to re-hang the stitches onto the original needles.
- Set the row counter on the same number when you have started to knit the first side of the neckline.

PLEASE NOTE: For types of knitting other than two-colour work, when dividing the garment for neckline, re-hang the stitches of the second side onto the needle hooks.

5. When dividing the garment, e. g. neckline, take a note of the pattern line you are on as well as the direction of the pattern reading in order to knit the second side in the same way as the first side.

6. Use the edge claws if necessary.

7. SINGLE DESIGN IN FAIR ISLE:

To avoid a gap on the edge of the design, proceed as follows:

- On the carriage side, slightly move the first needle knitting the main yarn without making the stitch slide behind the latch.
- Pass the second yarn under the needle, loop it back towards the left-hand side if the carriage is on the right-hand side, pass it under the needle again, then lay it onto the front flow combs.
- Lower the needle to position 1. When moving the carriage across, the second yarn will be fastened to the section knitted in main yarn.
- Gently move the carriage across the needles.
- Repeat this operation after each row.

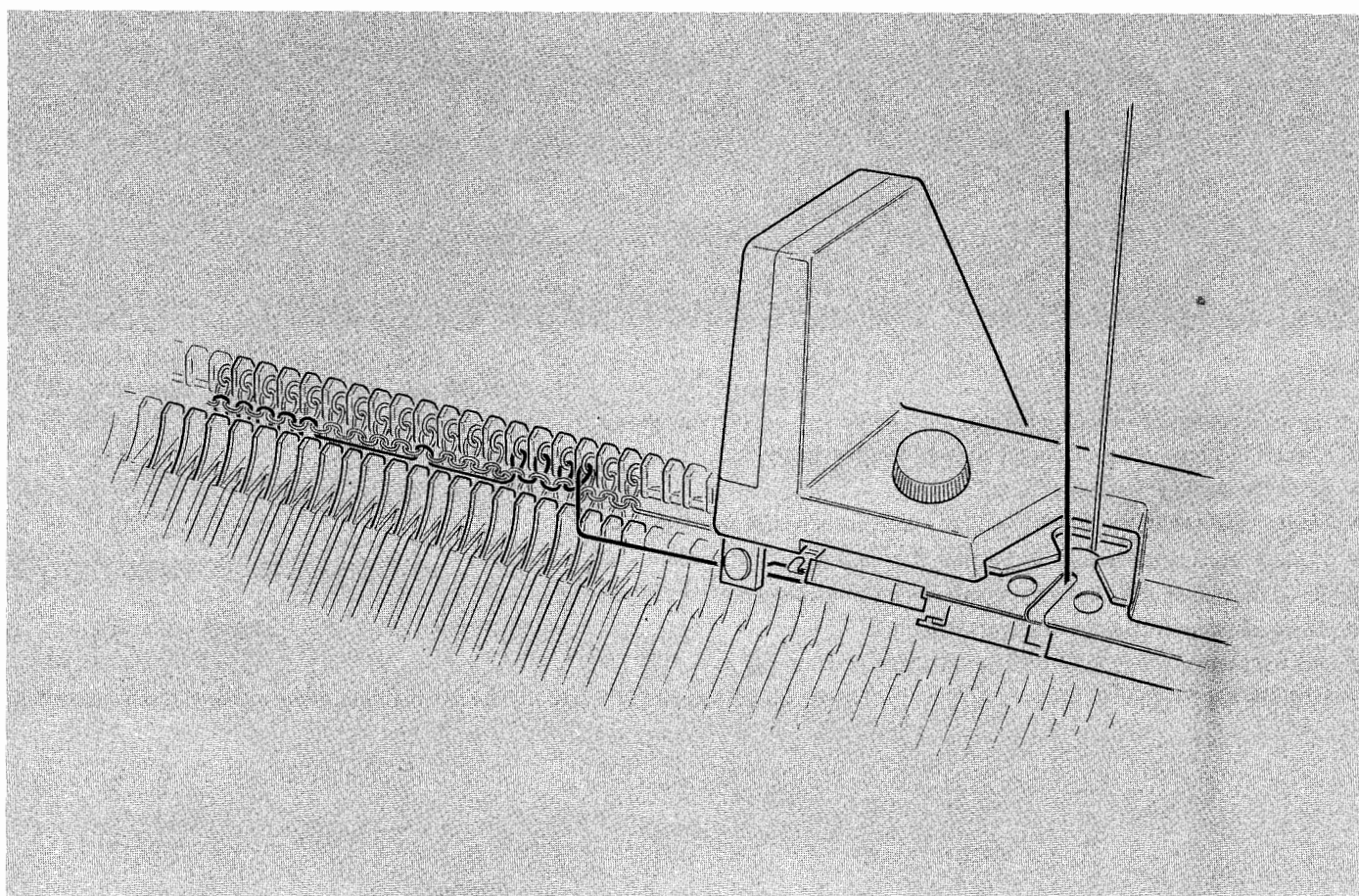

8. Always cover your machine carefully to protect it from dust.

VII. What to do if . . .

The carriage jams during knitting:

- Take a note of the pattern line which you are on as well as the direction of the pattern reading.
- When using the motor-drive, disconnect the engaging bolt and press down the speed controller to bring the drive guide to the end of the rail.
- Set the switch SELECTION STOP in lower position
- Loosen the cursor stop that has just been passed.
- Bring it against the cursor and push it in the direction it was knitting until it is disconnected from the carriage.
- If the second yarn guide is attached to the carriage, disengage the needle raisers as illustrated below (pull and turn them).

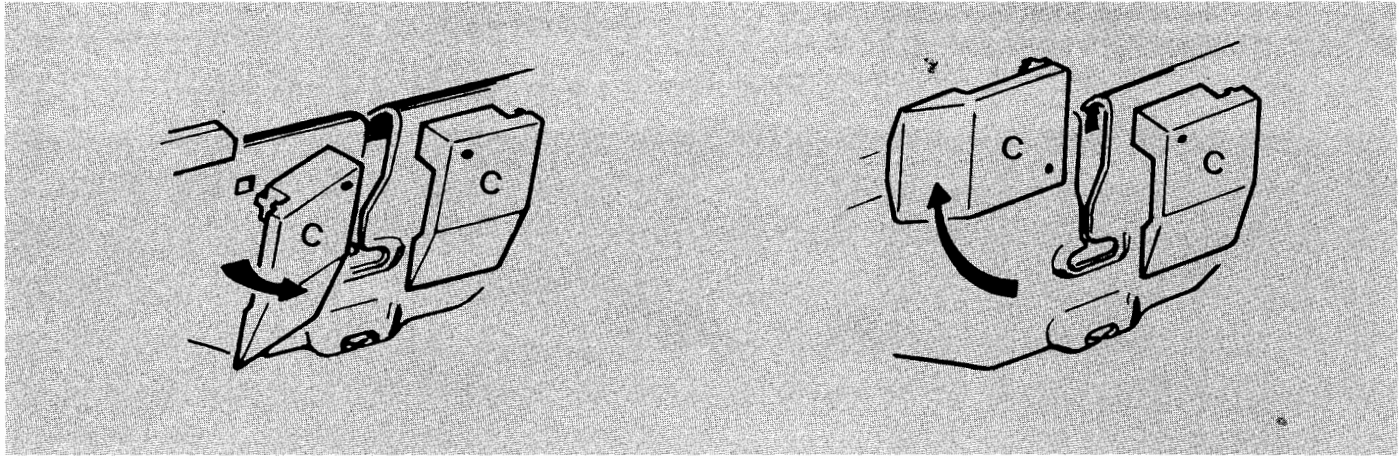

- Unlock the carriage and bring it back to its starting point.
- Lock the carriage back on the rail.
- Unpick the part of the row to bring the yarn back to the carriage side.
- Deduct this row from the row counter, if necessary.
- Reset the cursor and the cursor stop to their previous position, on the carriage side.
- Move all needles back to working position 1.
- Set the switch SELECTION STOP in upper position ▽.
- With the key PATTERN LINE ADVANCE + 1, reset, on the indicator, the pattern line to be knitted, in the required reading direction.

You have to undo one or several rows

- Take a note of the pattern line which you are on as well as the direction of the pattern reading.
- Set the switch SELECTION STOP in lower position • .
- Release the carriage if necessary and bring it to the right-hand side without knitting. Set the cursor to the right-hand side against the right-hand stop.
- Undo the rows and count them.
- Set the switch SELECTION STOP in upper position ▽ .
- Deduct from the row counter the number of rows you have unpicked.
- Using the switch PATTERN LINE ADVANCE, reset the programme onto the pattern line to be knitted.

PARTICULAR CASES:

a) Undoing rows using function XXX :

- Unpick until the main yarn is on the right-hand side and the second colour is on the left-hand side.
- For the first unpicked row in main yarn, re-set the pattern line shown on the indicator.
- For all following double rows unpicked in main yarn as well as in second colour, deduct one pattern line from the indicator.
- If the carriage, threaded with the second colour has stopped on the left-hand side, count the first unpicked row as a double row. Deduct one pattern line from the indicator.
- For all following double rows deduct one pattern line from the indicator.

b) Undoing rows using function □ .

- For the first unpicked row, re-set the pattern line shown on the indicator.
- Deduct only one pattern line from the indicator for all following double rows unpicked.
- Continue knitting with carriage at right-hand side.

c) Undoing rows using function .

- We recommend you unpick a complete design.
- Using the switch PATTERN LINE ADVANCE, bring the programme forward until the number 1 appears for the second time on the indicator.

You cannot cast-on:

- Check that the Jacquard keys have been cancelled.

The needles selected for two-colour work remain in holding position 3:

- Unpick one row.
- Using the single eyelet tool, bring the needles from holding position 3 back to working position 1.
- Replace the carriage to the side of the yarn.
- Check that the Jacquard key is correctly depressed.
- Reset, on the indicator, the number of the pattern line to be knitted, in the required direction.
- Deduct from the row counter the number of rows you have unpicked.

The design is not forming

Check that:

- The indicator is lit up.
- The switch SELECTION STOP is set in upper position .
- The cursor is on the same side as the carriage.
- The settings of the carriage and Memo II correspond to the instructions given in the catalogue illustrating the design.
- The cursor stops are correctly positioned.

The edge stitches of a single design knit both yarns:

Check that:

- The cursor stops have not moved during knitting.
- The edge claws are rehung every ten rows.

A tuck stitch or slip stitch is not correctly knitted:

If one or several needles (carrying tuck stitches or not) have not knitted for several rows, do not knit normally after the needle selection has changed, check that:

- There are not too many weights.
- The front bed is set in upper position.
- The flow combs are opposite.
- The cursor is correctly positioned (see page 2)
- The needles are not damaged.

Explanation of the symbols

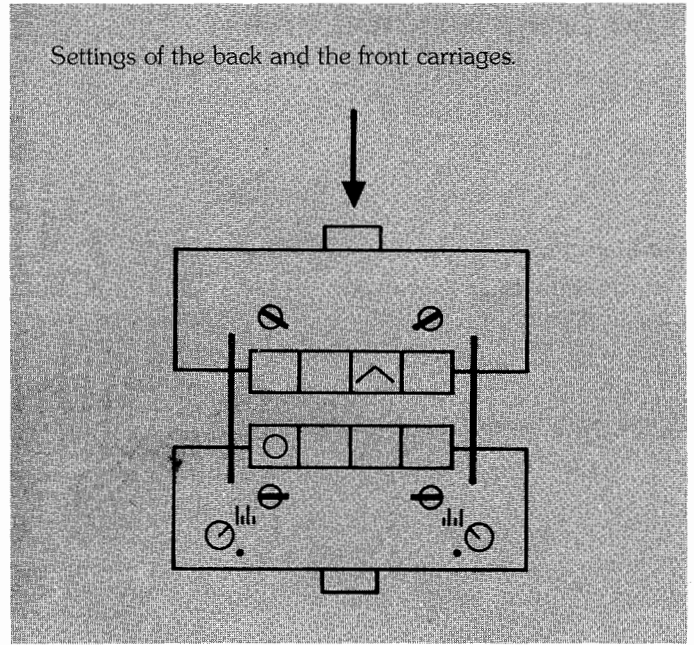
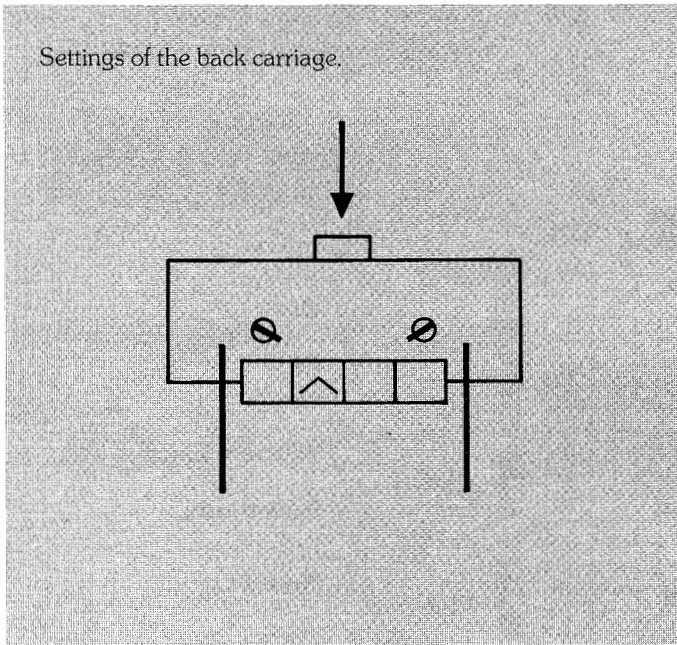

The arrow pointing towards the Jacquard key indicates that it has to be depressed simultaneously with the KNIT key. To cancel the Jacquard key, depress the CANCEL key.

NECESSARY ACCESSORIES TO KNIT CERTAIN PATTERNS:

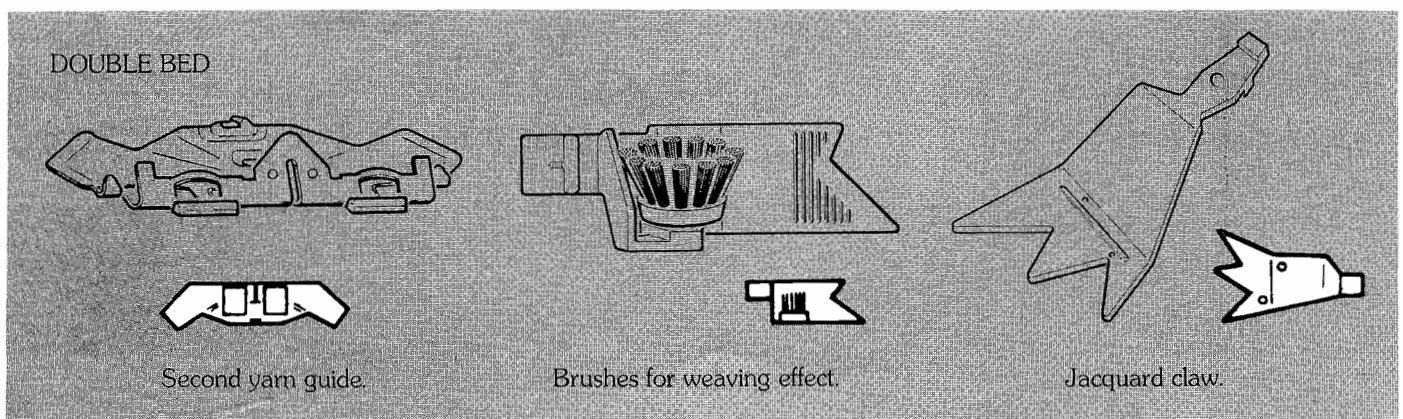
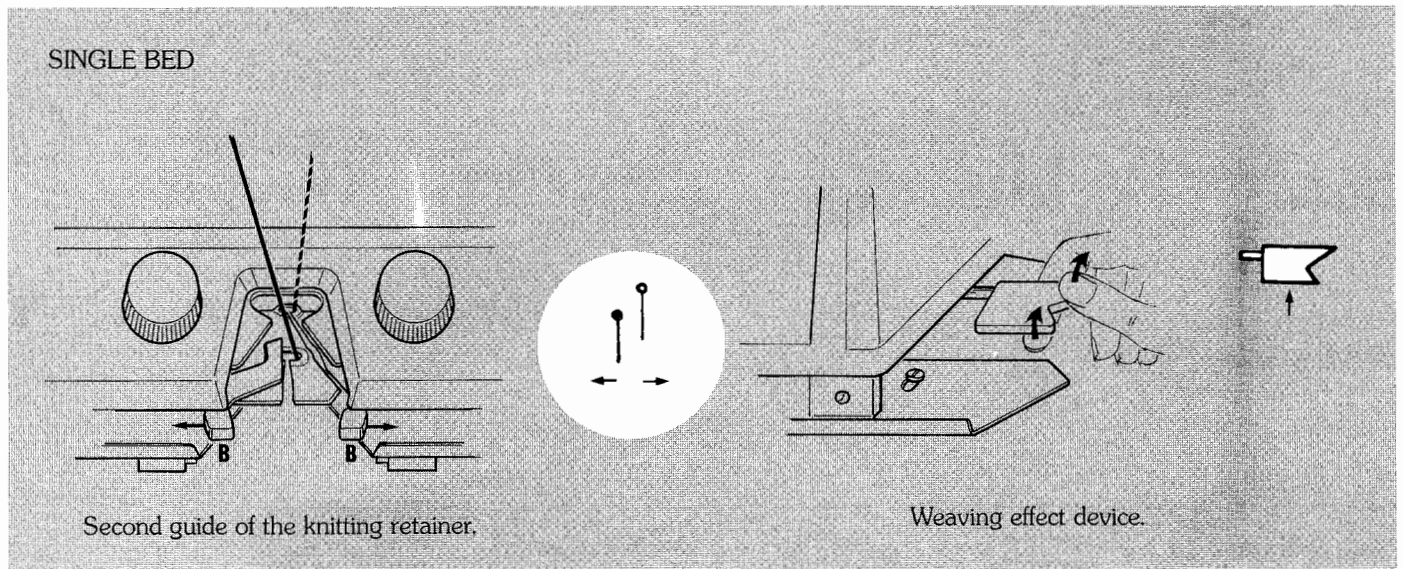

The programme-card

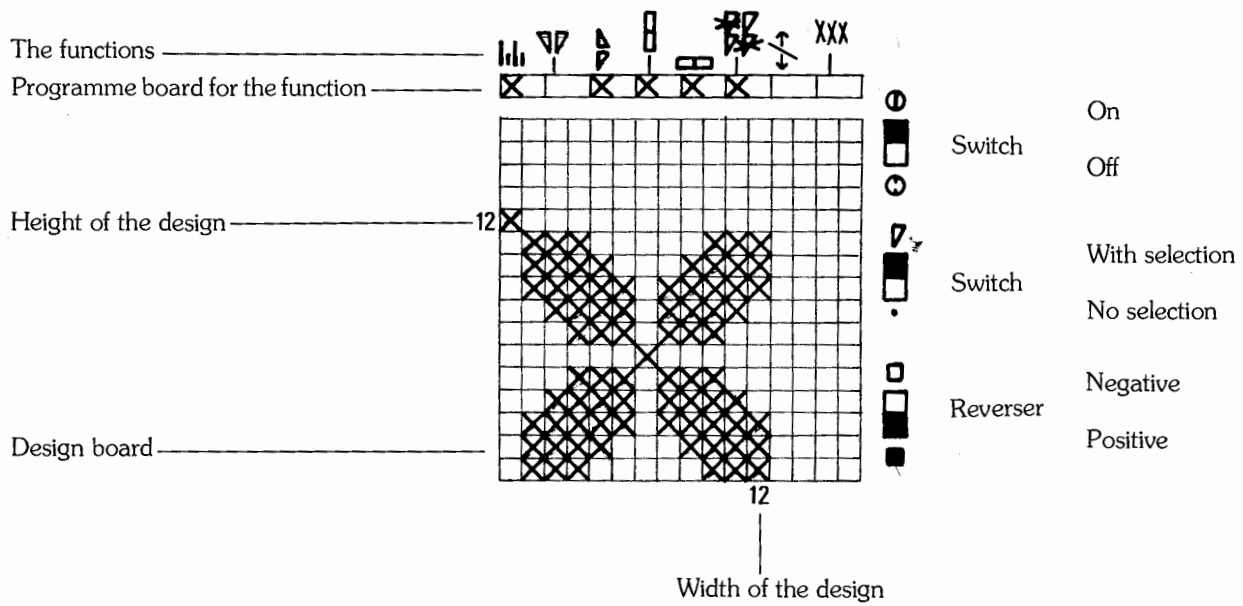

THE FUNCTIONS

Every other needle selection (bird's eye)		Horizontal symmetry	
Vertical symmetry		Twice each row	
Twice each stitch		Pattern space	
Row advance stop		Norwegian Jacquard	

When knitting any pattern, consult the stitch size chart below for:

- the recommended thickness of the yarn
- the stitch size
- the needle bed space
- the position of the flow combs
- the position of the front bed

HOW TO READ THE STITCH SIZE CHART



Thickness of the yarn in comparison with hand knitting needles. That indication is given on the paper band of each ball of yarn.

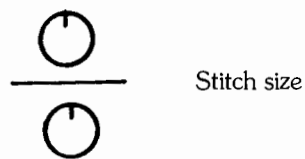

Stitch size



Front bed in normal position

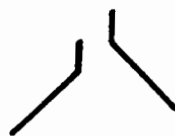

Front bed in upper position



Needle bed space



Flow combs alternate Flow combs opposite

	US 0.1 A 2	UK 14.13 2 1/2	US 1.3 A 2 1/2	UK 13.11 3	US 3.4 B 3	UK 11.9 3 1/2	US 4.6 B 3 1/2	UK 9.8 4	US 6.7 C 4	UK 8.7 4 1/2
I Tuck stitches	5	5 4 1/2	6	5 4 1/2	8	5 4 1/2				
II Slip stitches	5	5 4 1/2	6	5 4 1/2	8	5 4 1/2	10	3 4 1/2	12	4 4 1/2
III Fair Isle	6	3 4 1/2	7	3 4 1/2	9	4 4 1/2	11	4 4 1/2		
IV Jacquard method 1	2 2 1/2	3 4	3 3 1/2	3 4	4 4 1/2	4 4	5 3 1/4	4 4		
V Jacquard method 2	3	3 4	4	3 4	5	4 4				
VI Jacquard method 3	3 3/5	4 4								
VII Norwegian Jacquard	3	4 4	4	4 4	5	4 4	6	4 4	7	5 4
VIII Weaving effect	5	6 4 1/2	6	6 4 1/2						

HOW TO USE THE PATTERN STITCH DESIGNS SHOWN IN THIS BOOK

1. Set the switches as illustrated on the right-hand side of the diagram corresponding to your design.
2. Transfer the design onto the transparent paper. Please note that the same diagram can be used for one or more designs.
3. At the bottom and at the left-hand side of each diagram you will find the width and the height of the design.

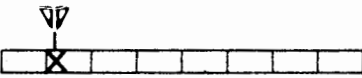
4. Above the corresponding diagram or next to the chosen design, you will see the functions  to be programmed when the letter F is shown on the indicator.

Particular cases

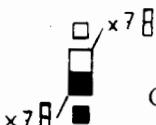
A.  Change the position of the reverser every 7 rows.

B. Set the reverser to the required position  if it is shown next to the design.

C. The functions to select for decorative designs (page 64 to 67) are shown at the side of each knitted design.

TUCK STITCHES (I)

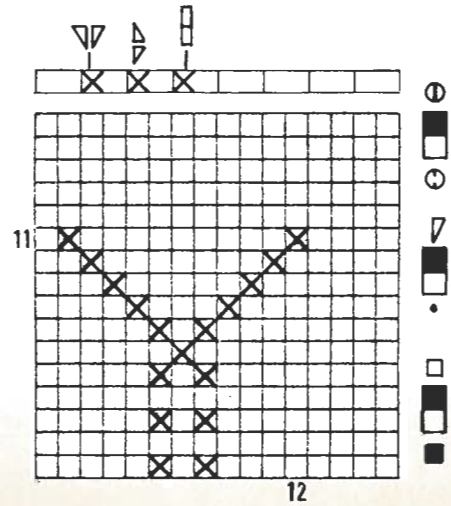
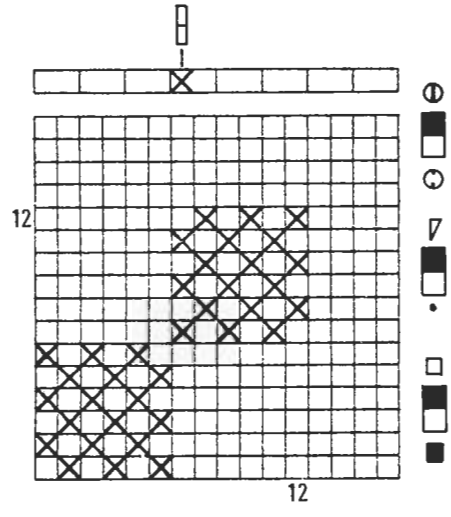
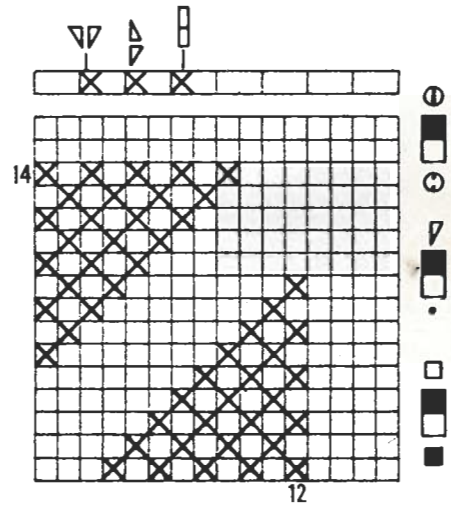
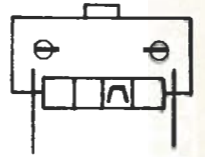

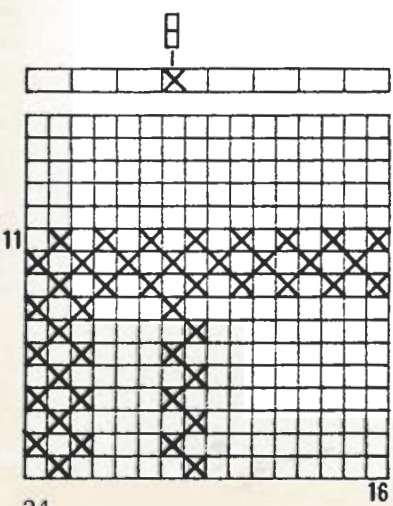
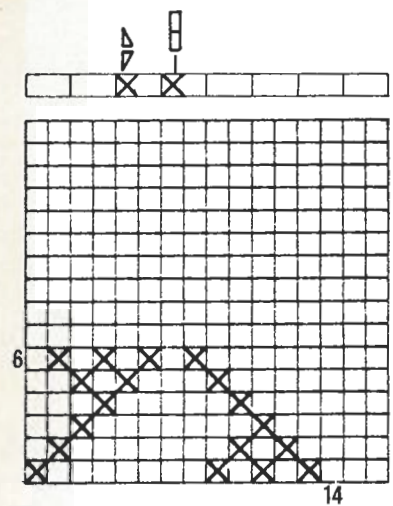
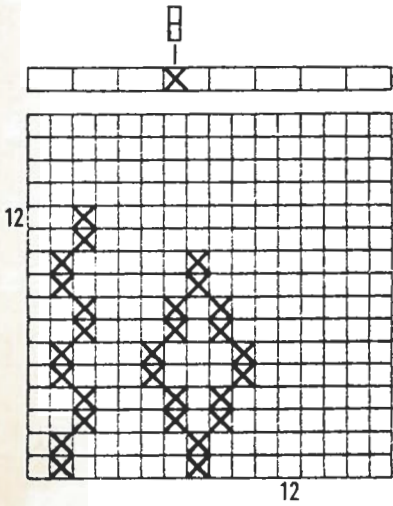
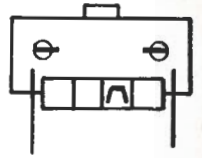
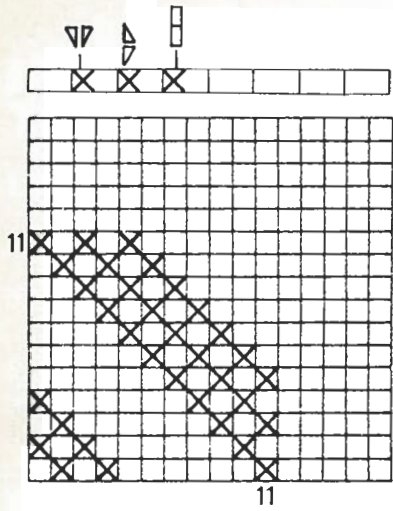

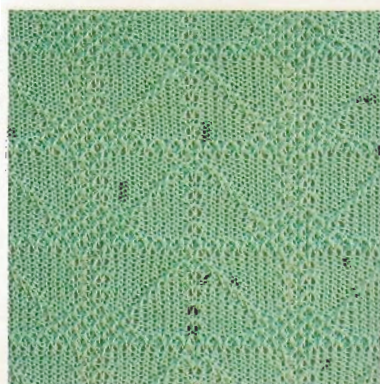
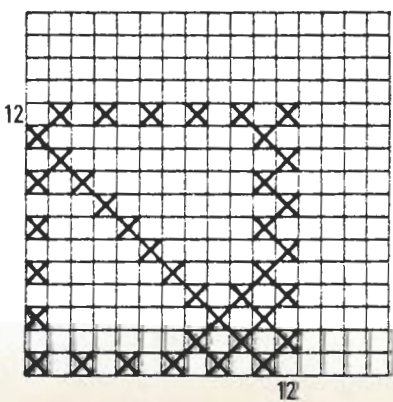
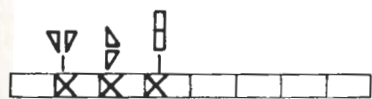
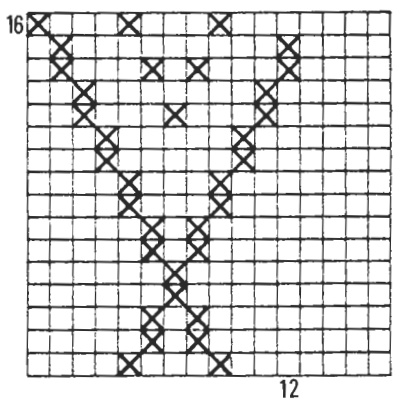
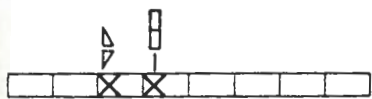
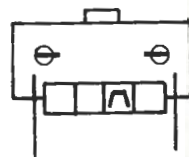
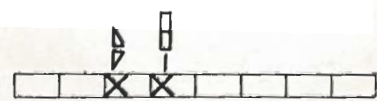
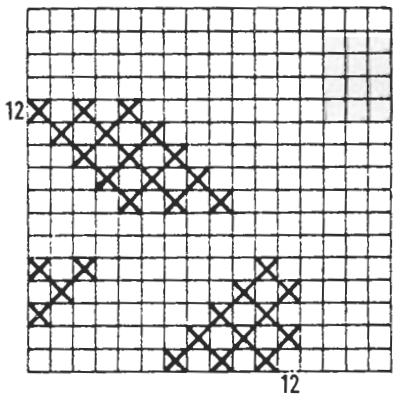
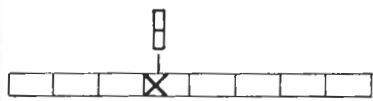

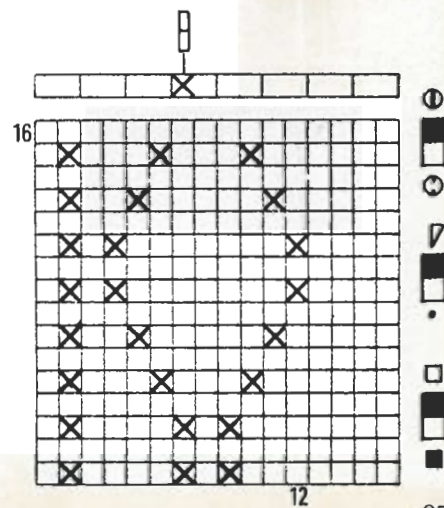
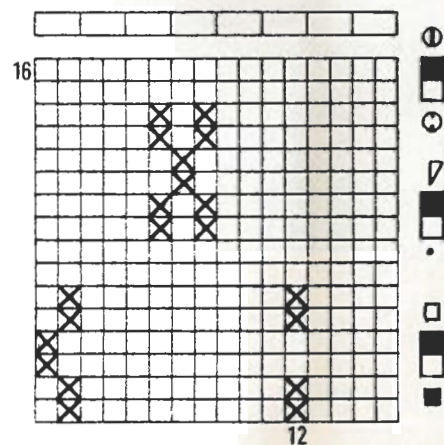
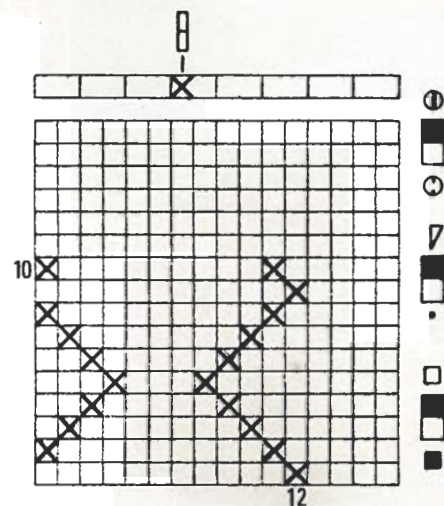
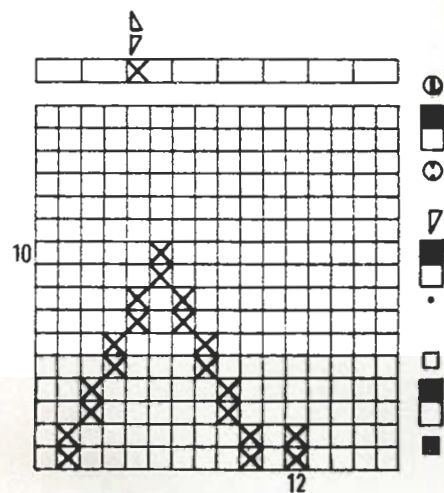
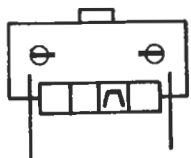

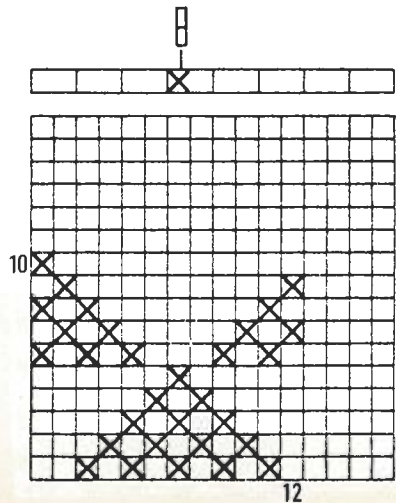
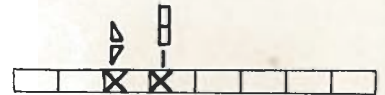
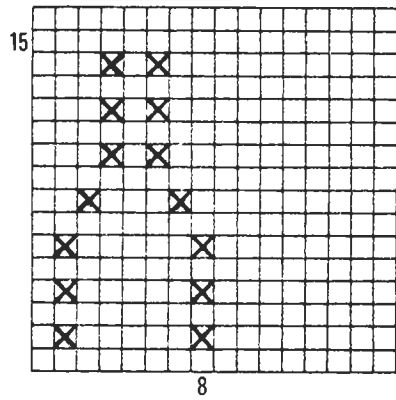
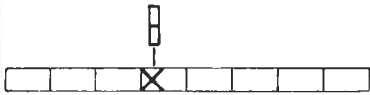
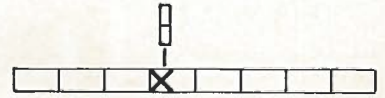
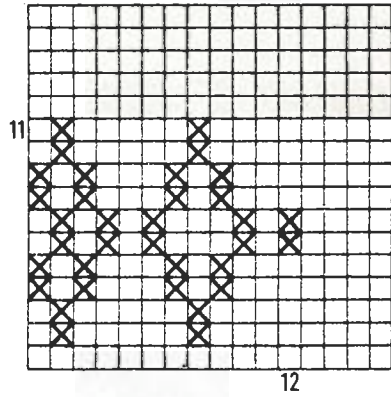
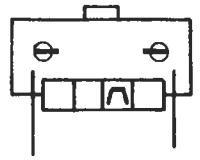

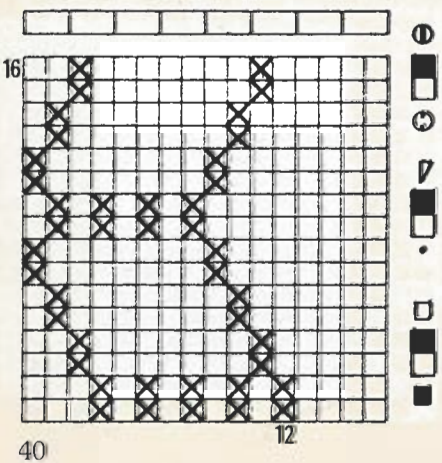
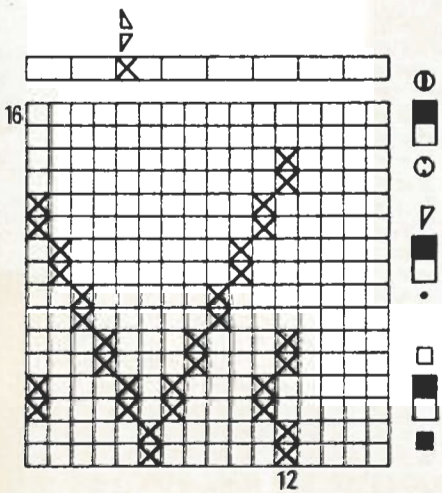
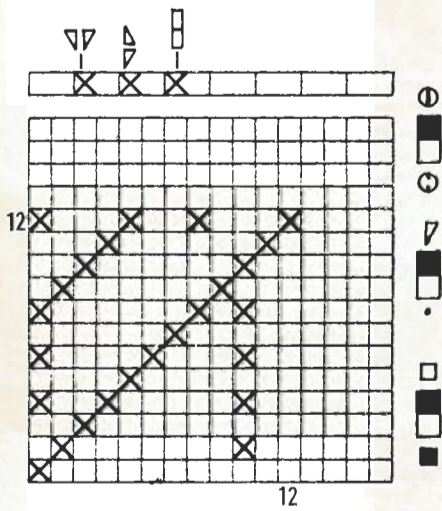
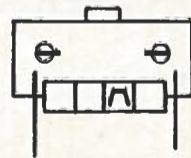
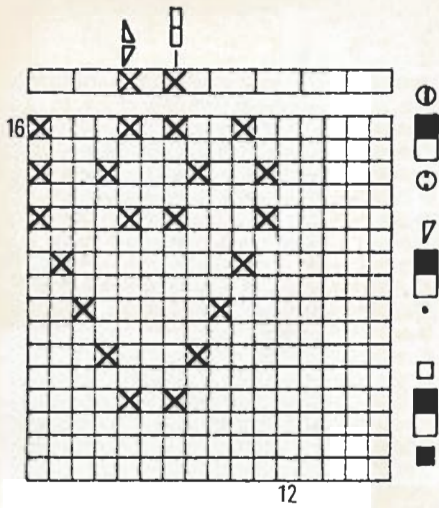

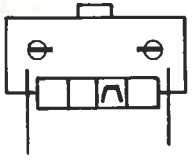

MULTICOLOURED TUCK STITCHES

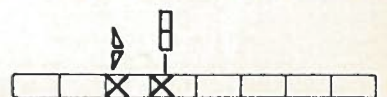
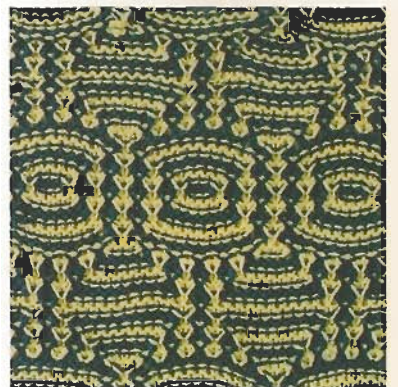
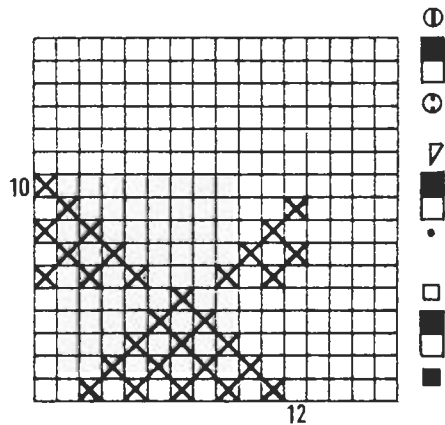
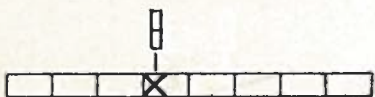
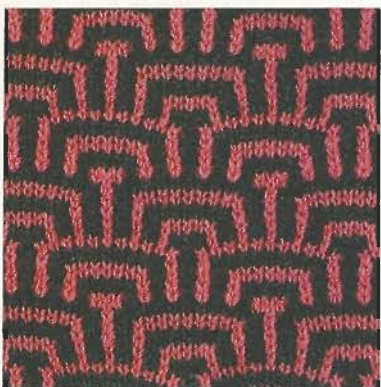
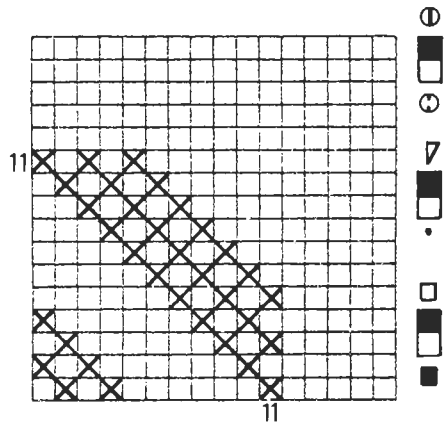
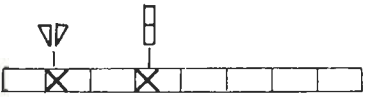
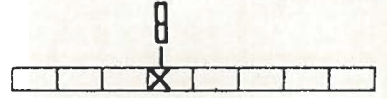
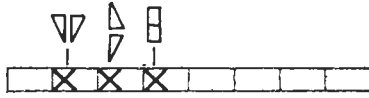
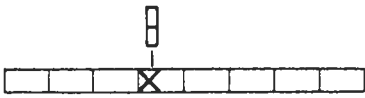
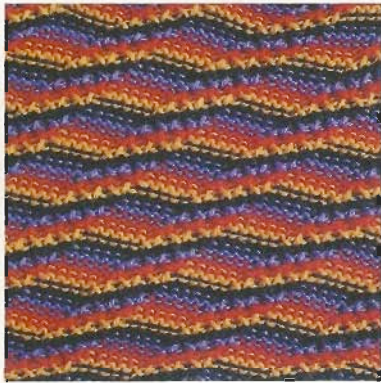

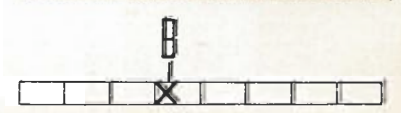
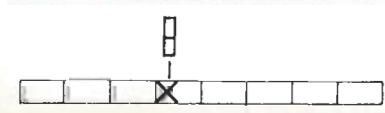
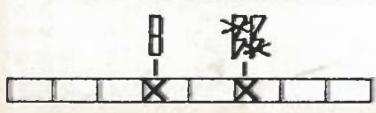
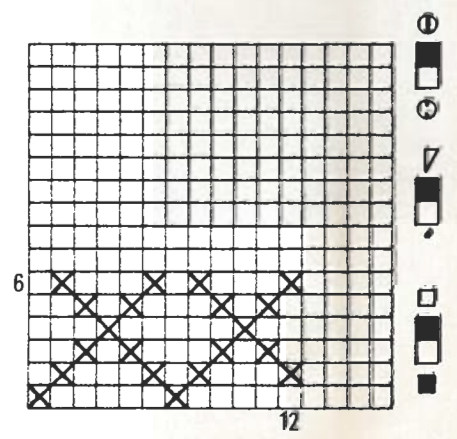
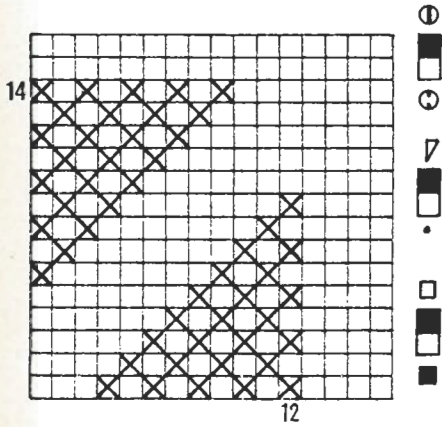
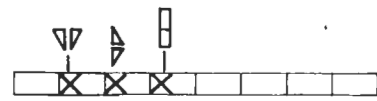
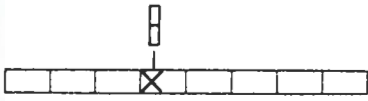
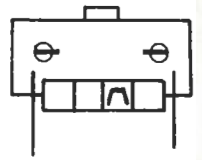

SLIP STITCHES (II)

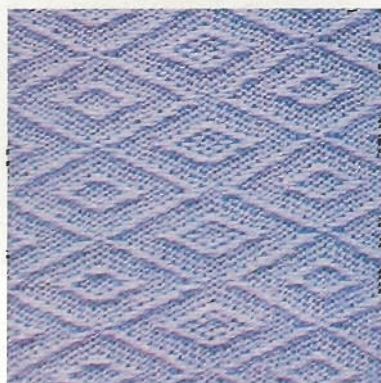
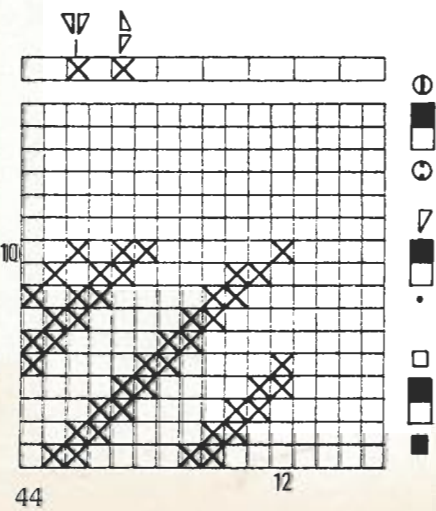
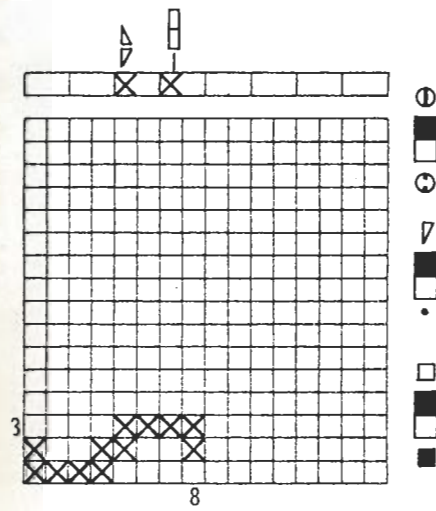
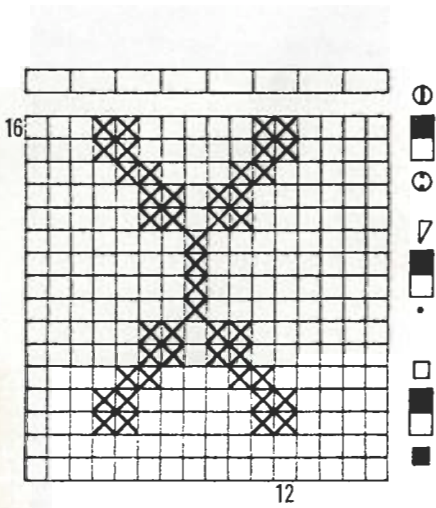
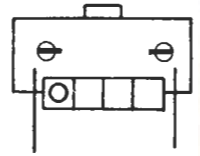

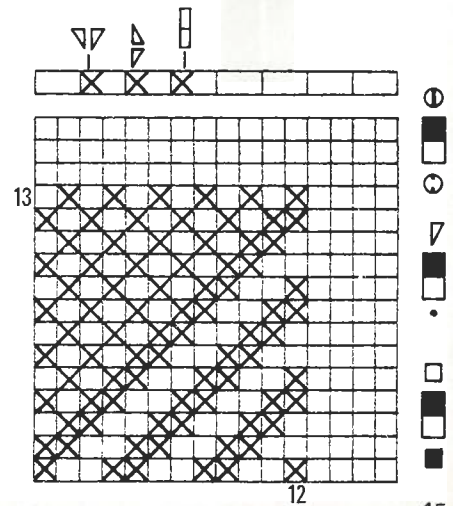
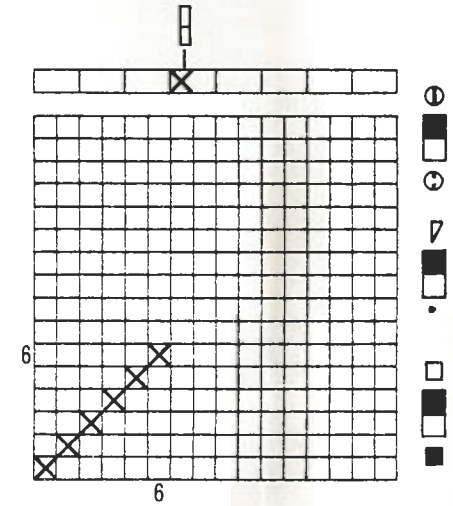
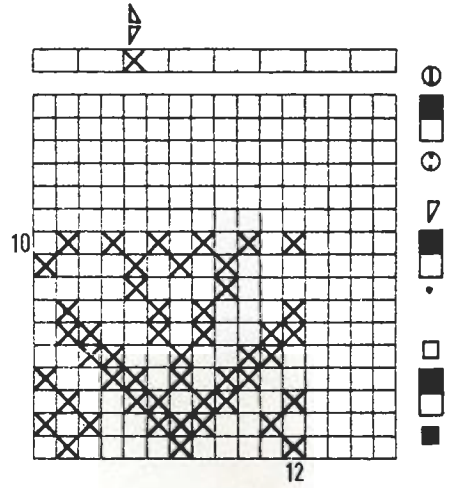
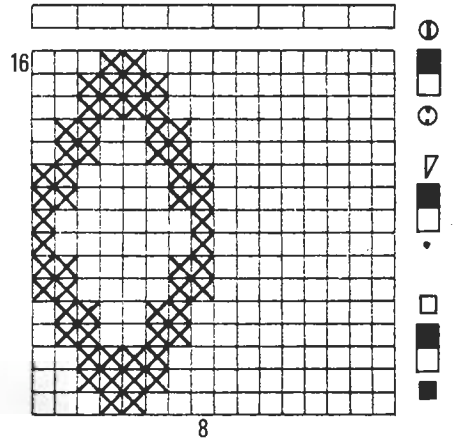
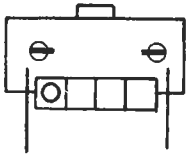

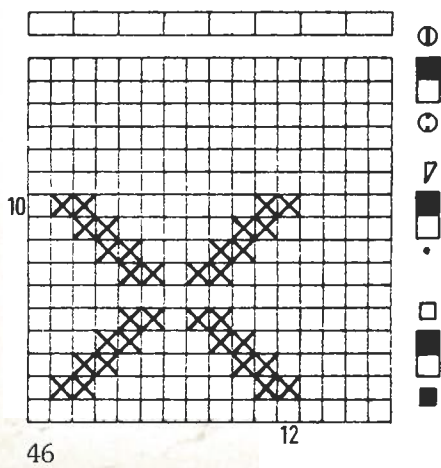
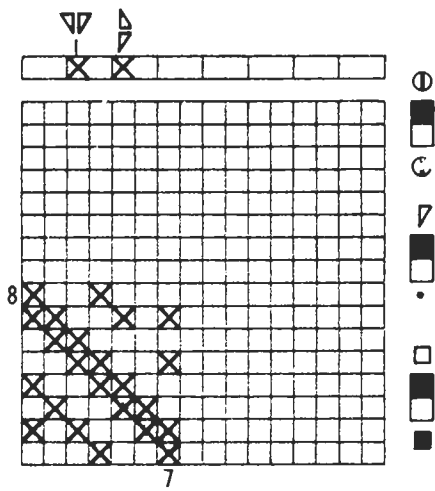
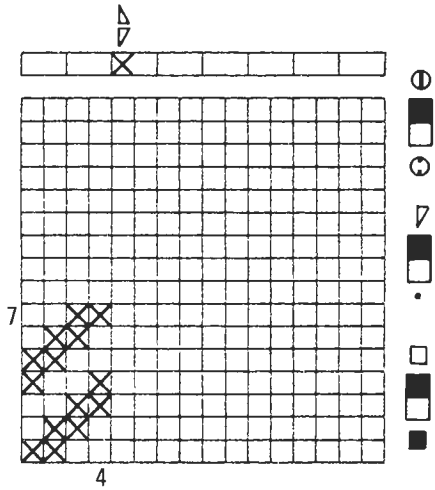
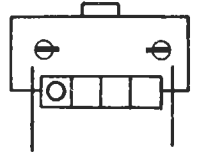
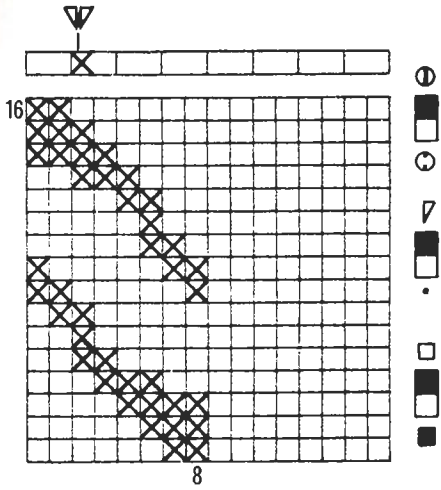

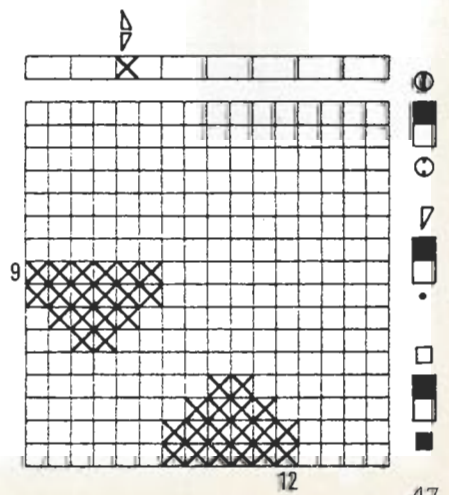
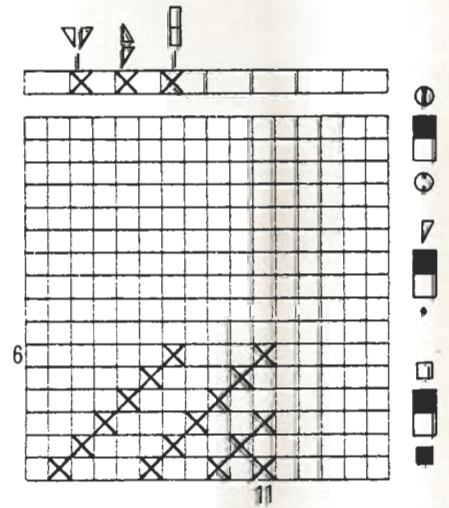
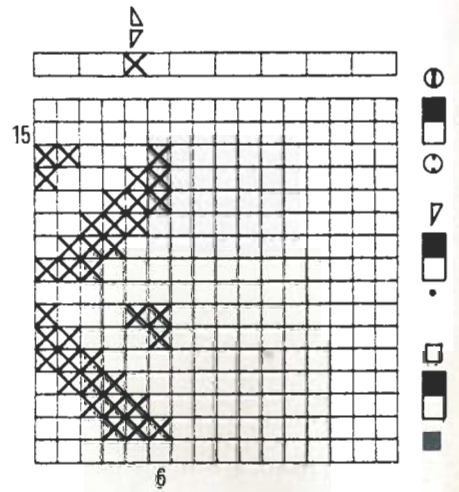
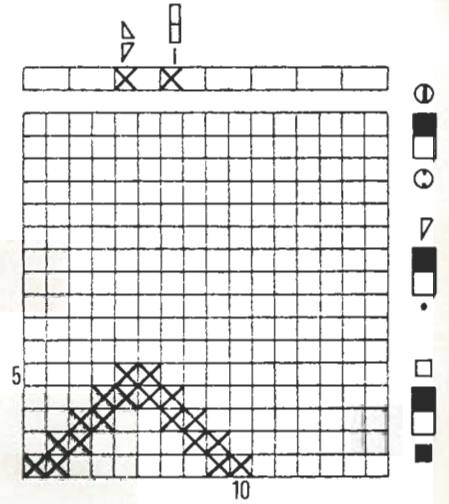
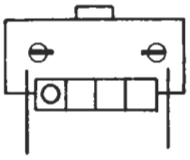

FAIR ISLE (III)



JACQUARD method 1 (IV)

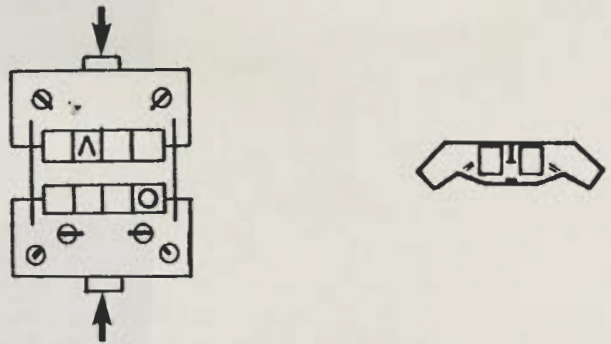

JACQUARD method 2 (V)

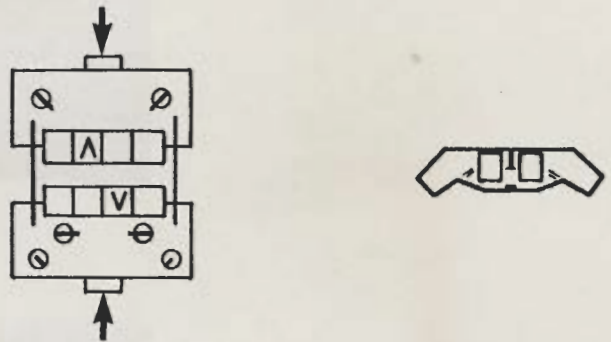

JACQUARD method 3 (VI)

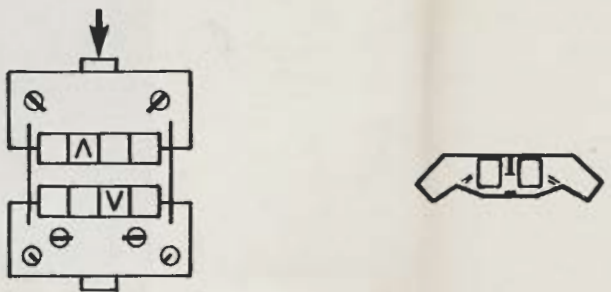

NORWEGIAN JACQUARD (VII)

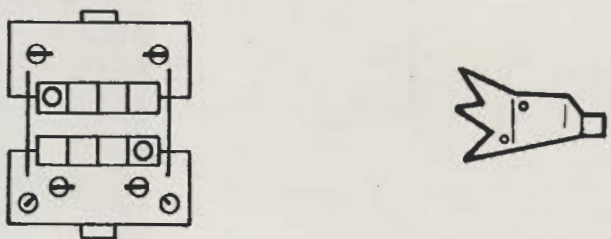

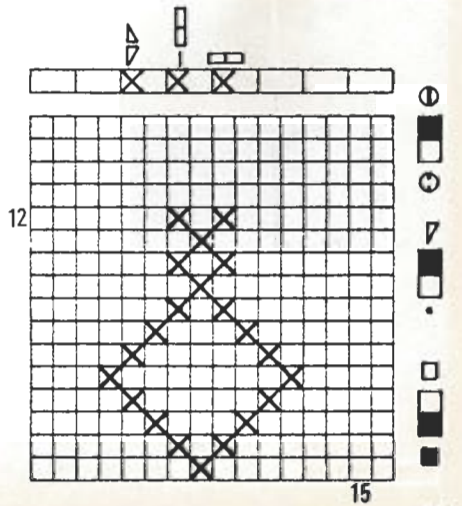
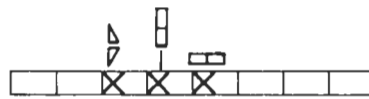
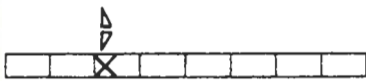
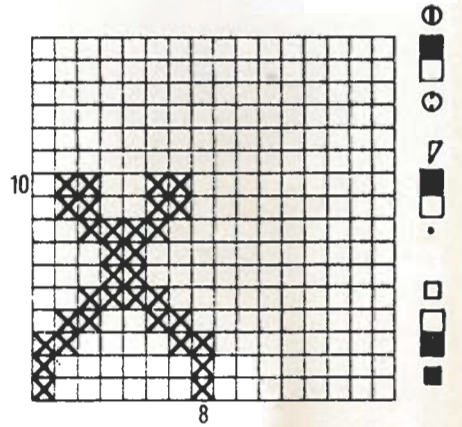
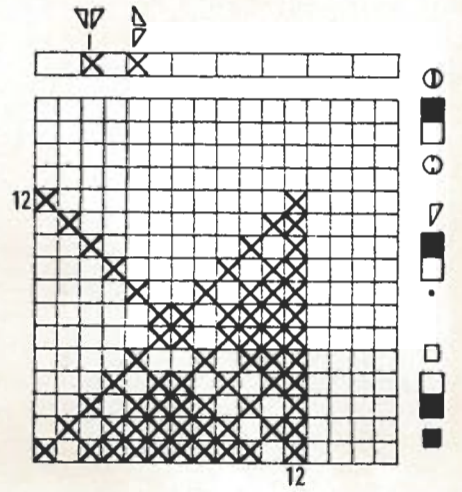
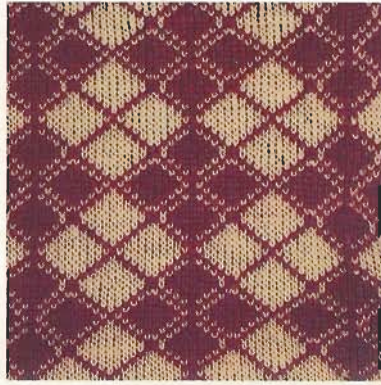

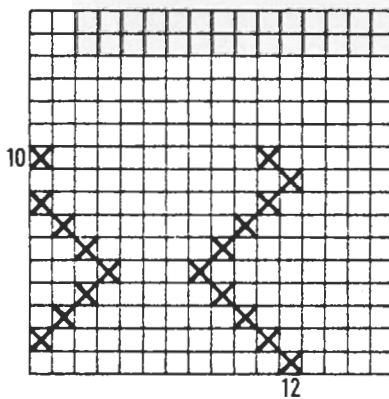
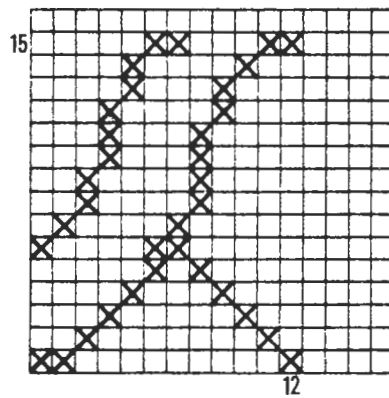
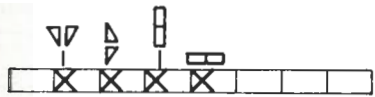
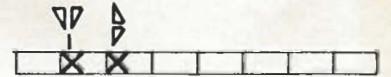
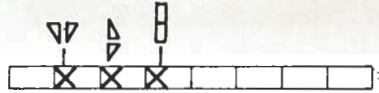
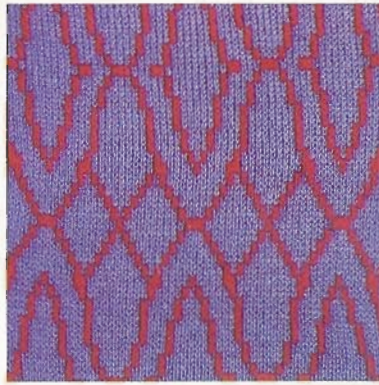
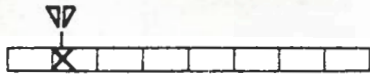



紮

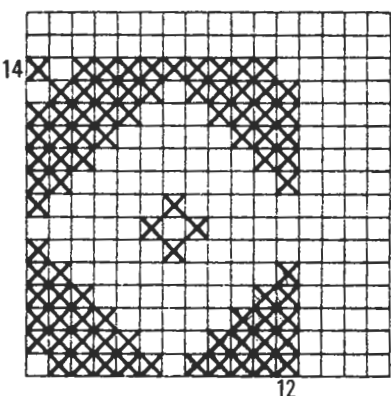
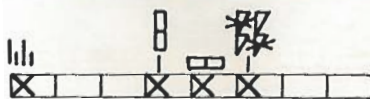
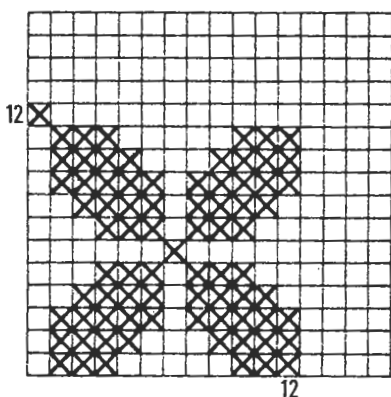
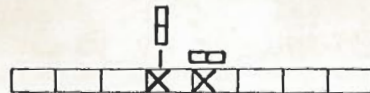

紮



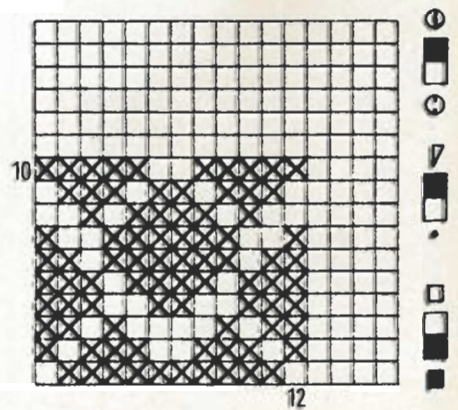
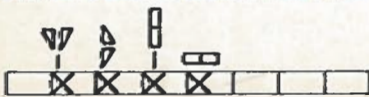
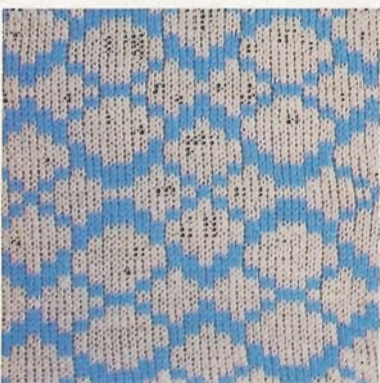
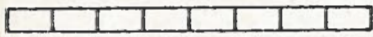
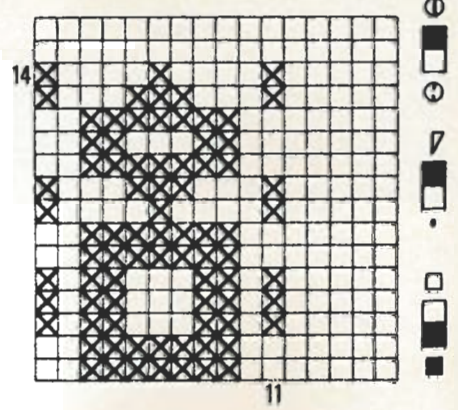
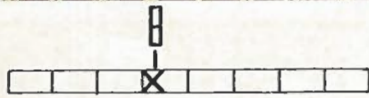
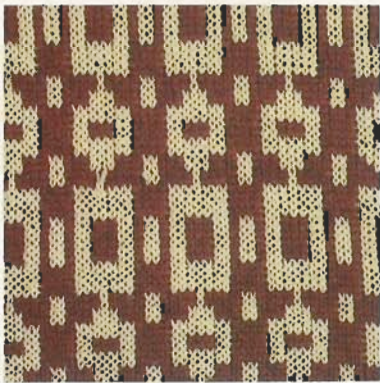
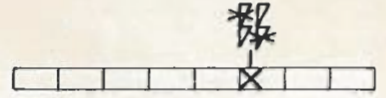
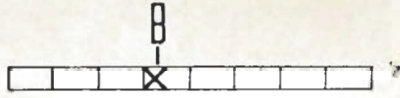
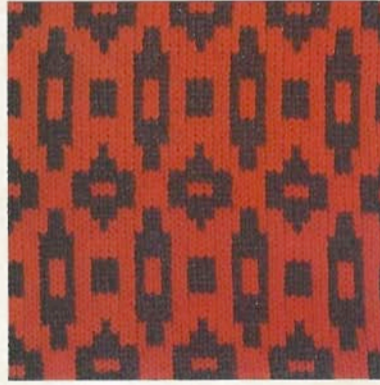
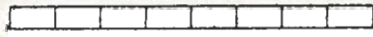
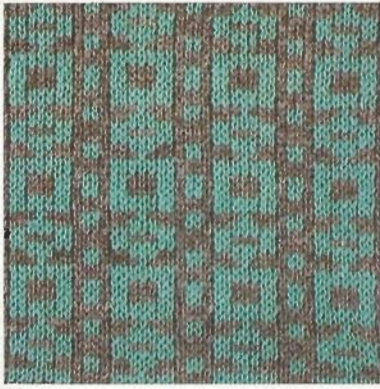

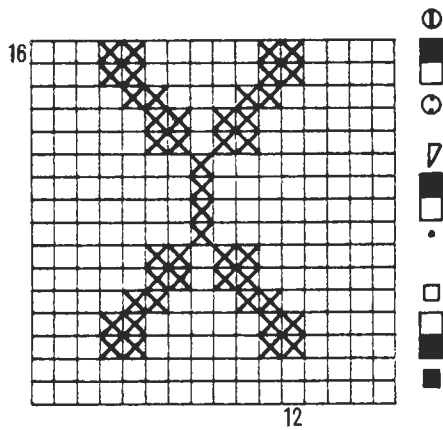
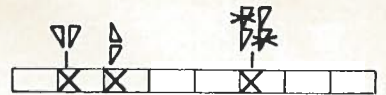
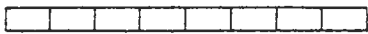
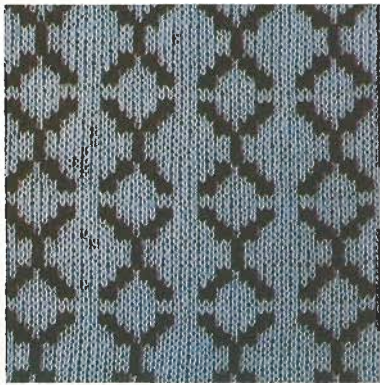

- ⊖
-
- ◉
- ▽
-
-
-
-

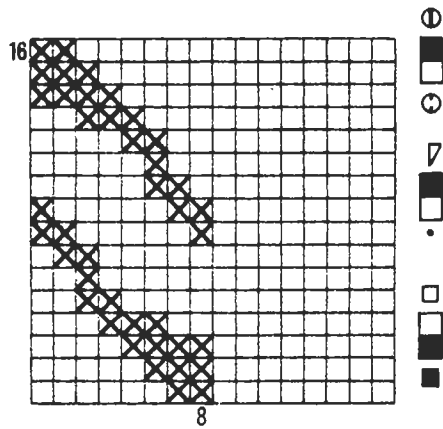
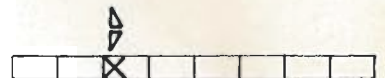

- ⊖
-
- ◉
- ▽
-
-
-
-



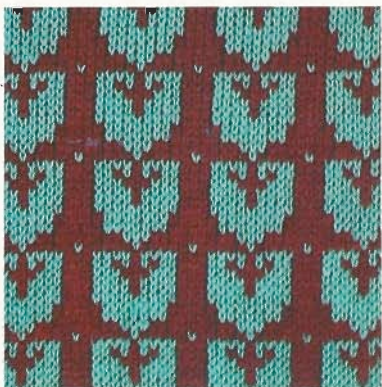
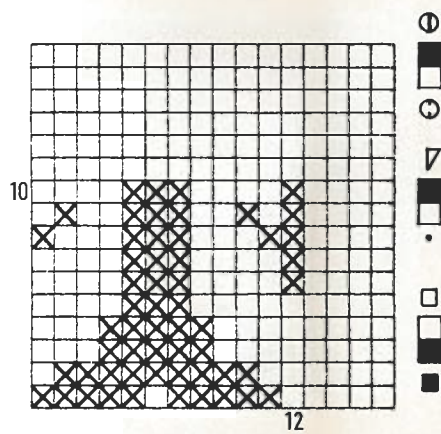
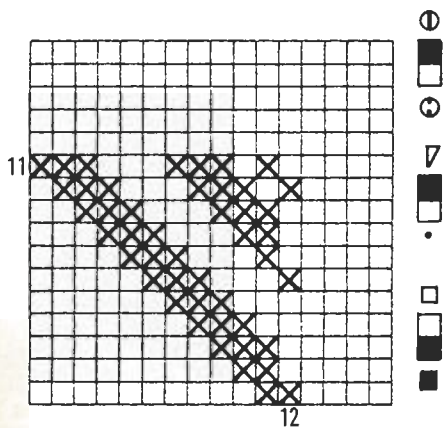
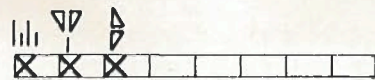
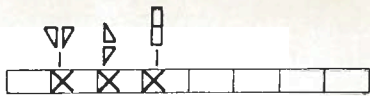
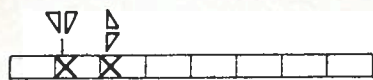

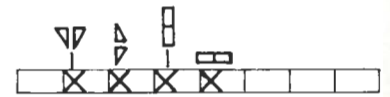
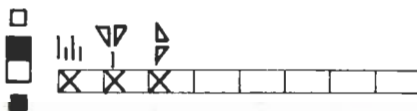
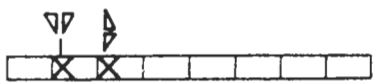
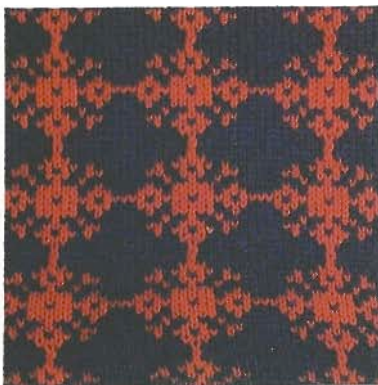
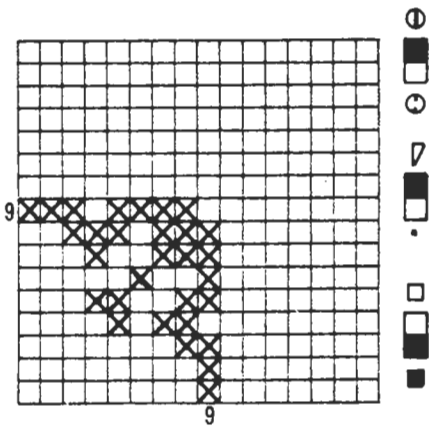
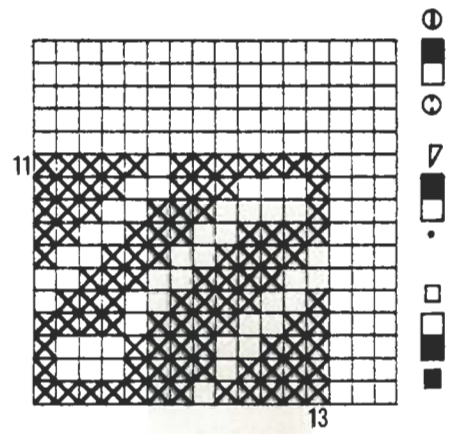
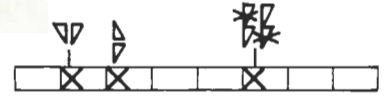
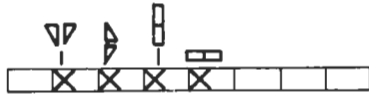

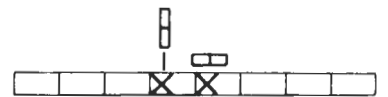
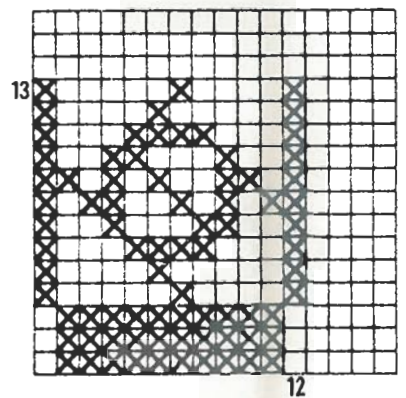
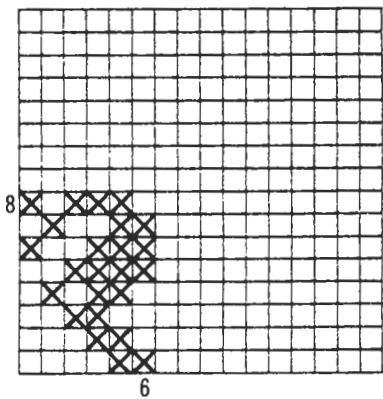
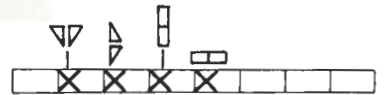
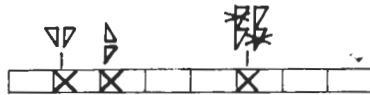
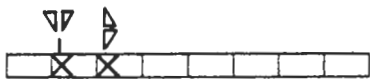
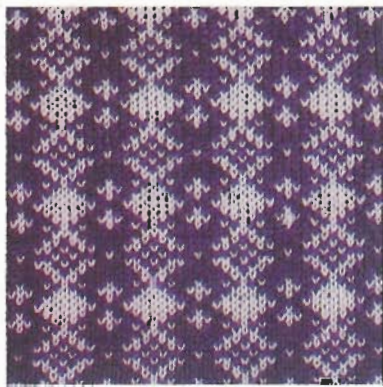

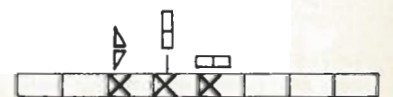
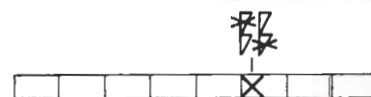
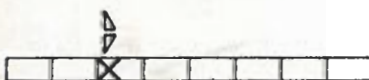
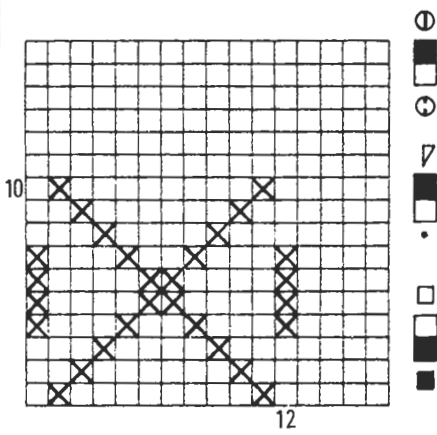
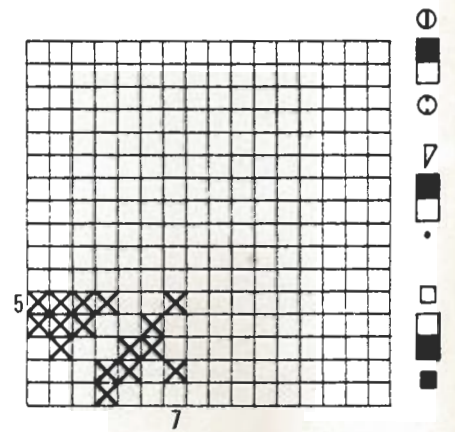
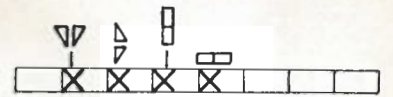
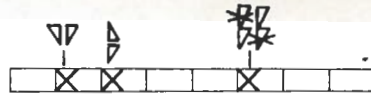
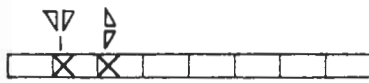

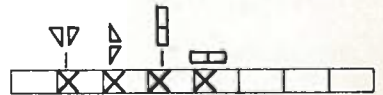
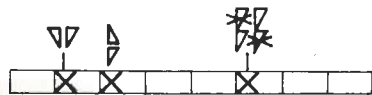
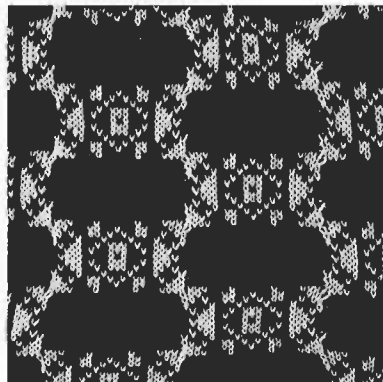
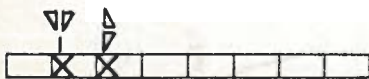
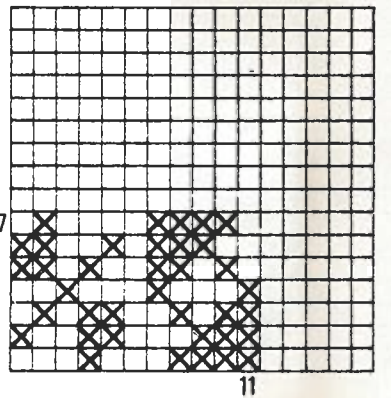
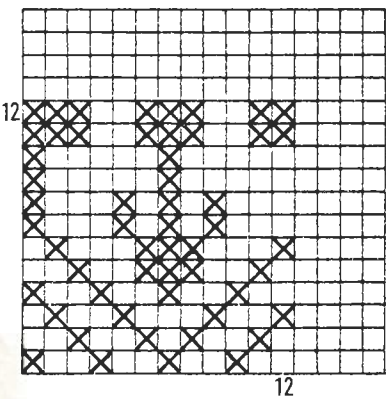
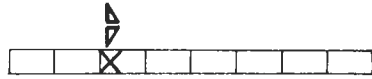

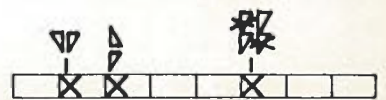
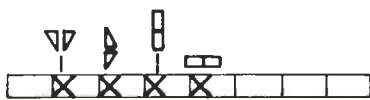
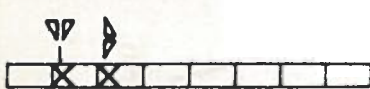
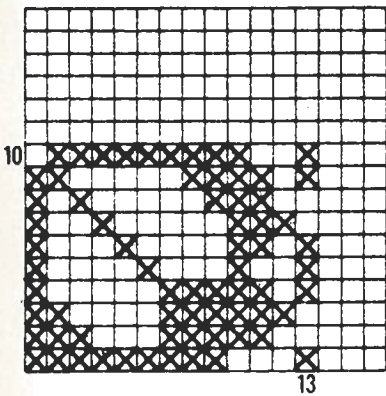
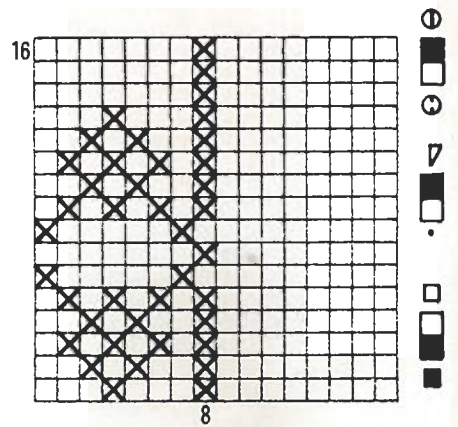
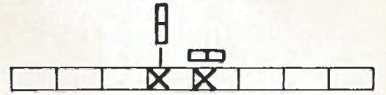
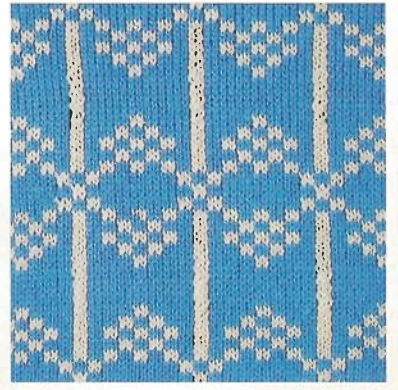
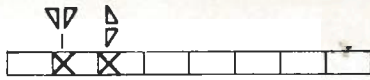
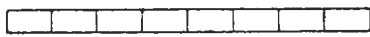
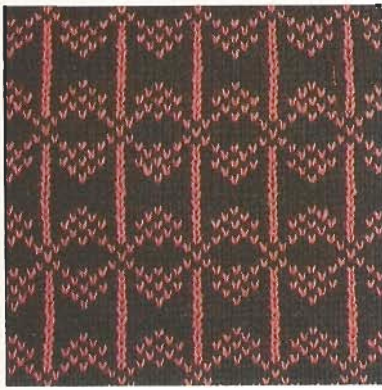

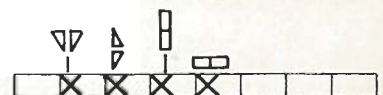
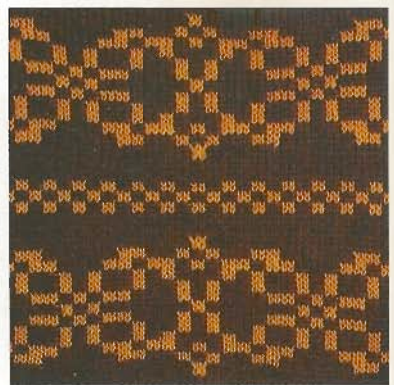
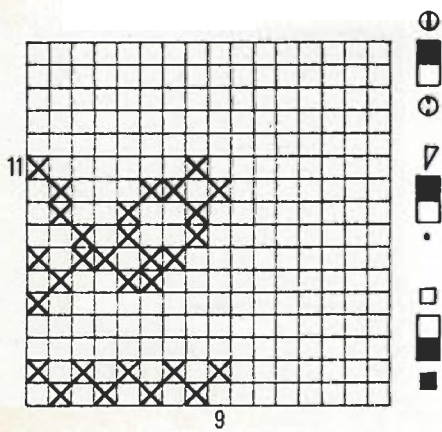
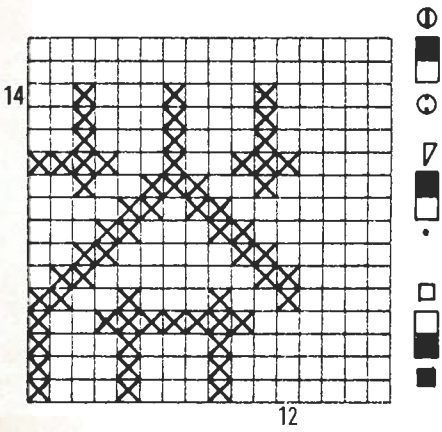
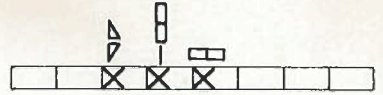
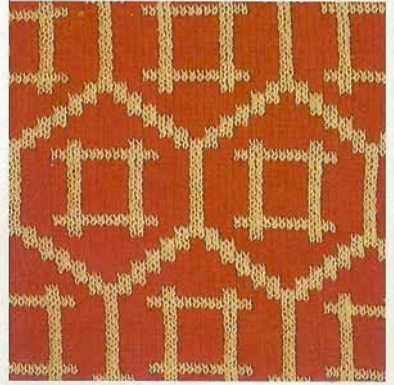
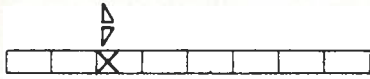

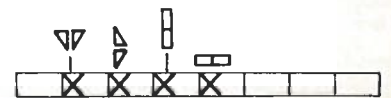
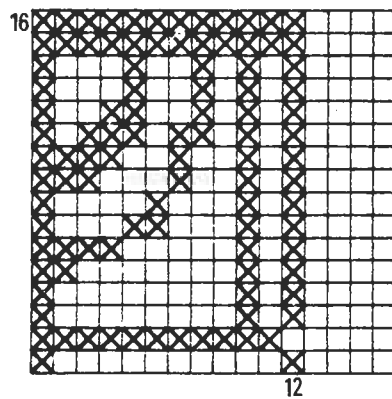
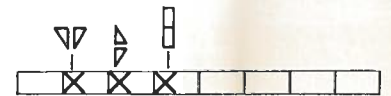
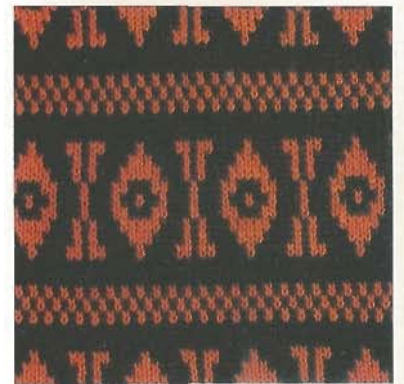
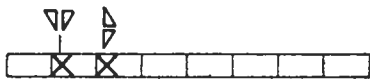
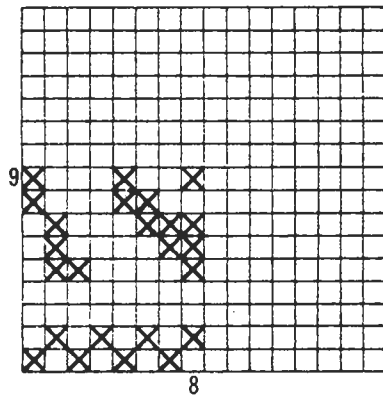
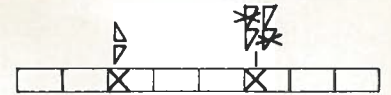
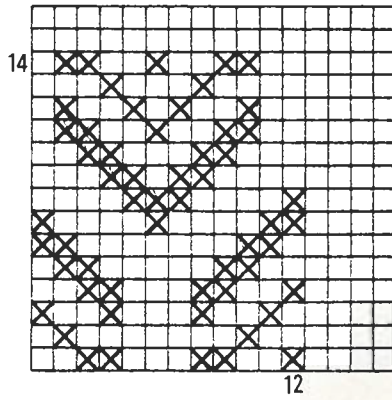

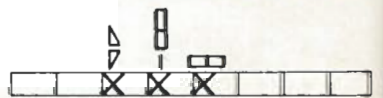
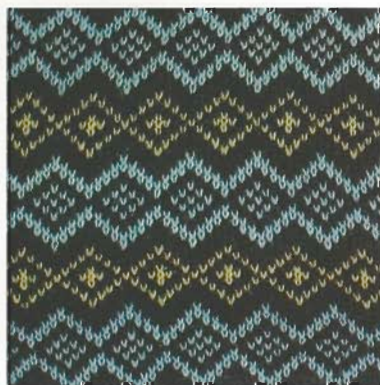
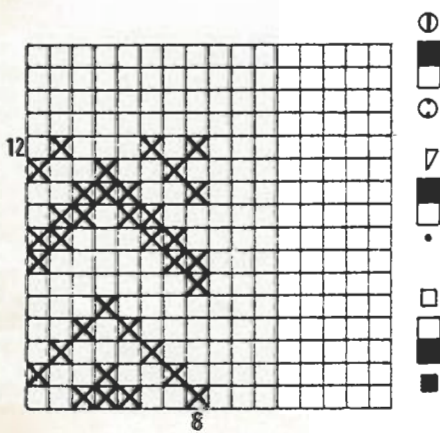
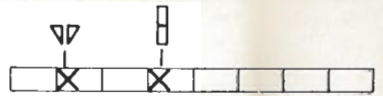
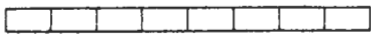
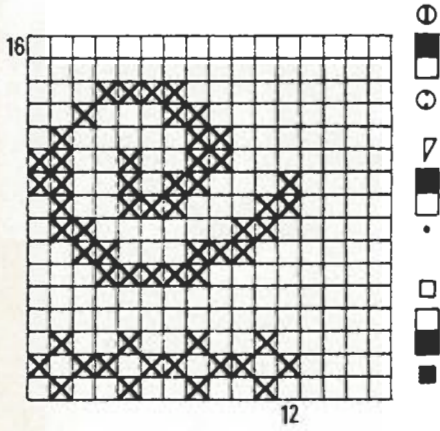
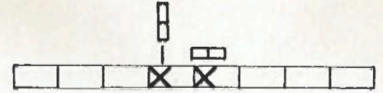
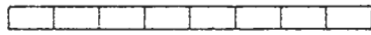
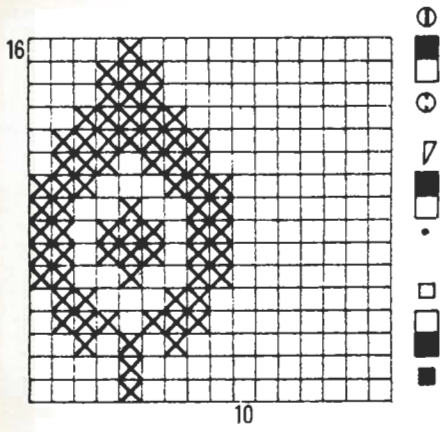

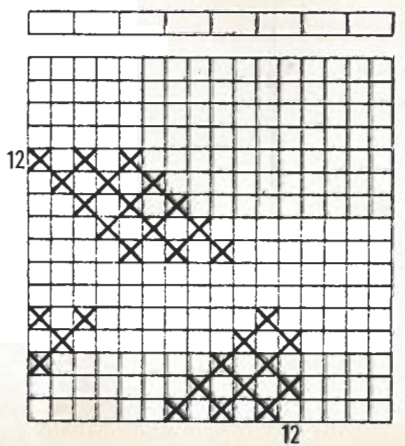
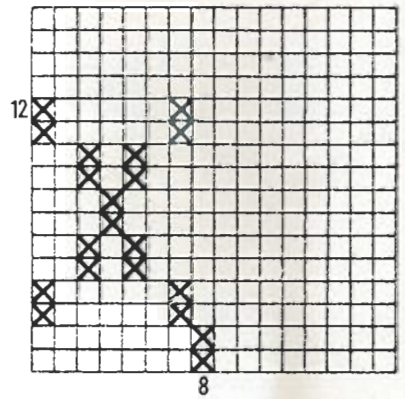
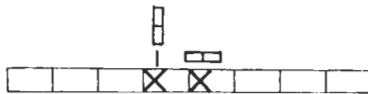
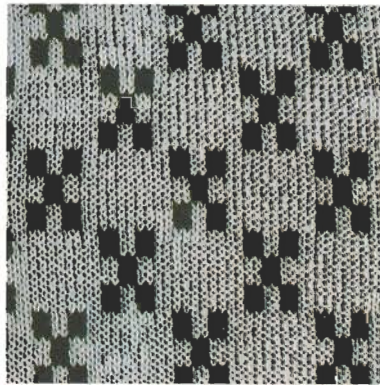
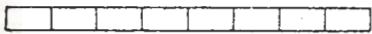
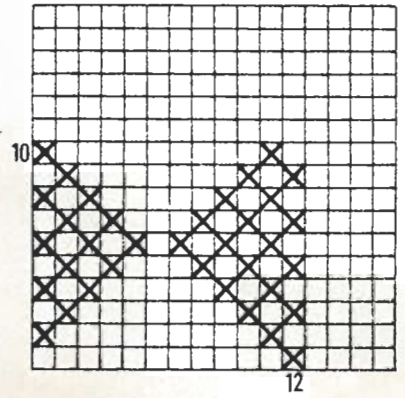
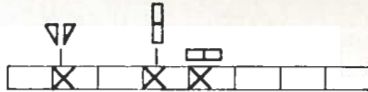
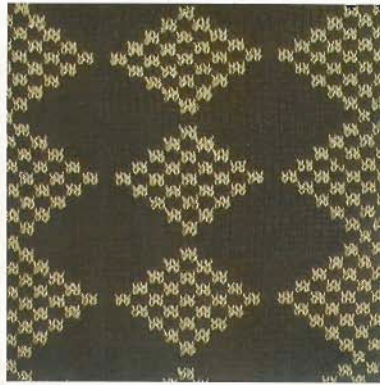
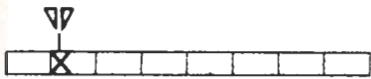

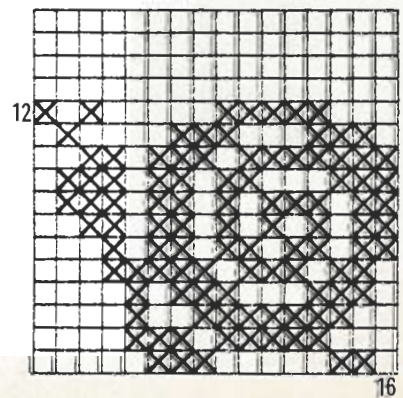
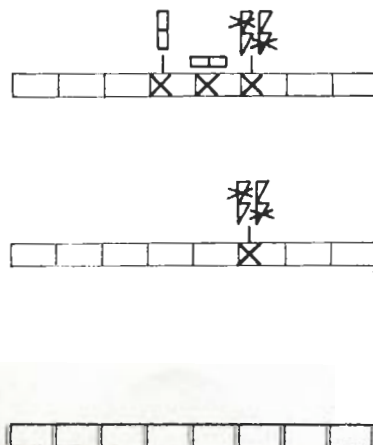
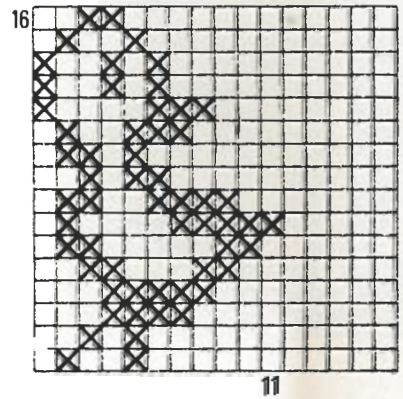
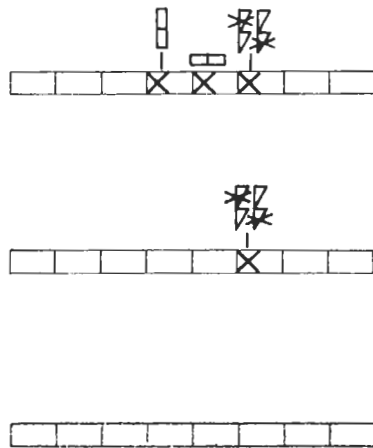
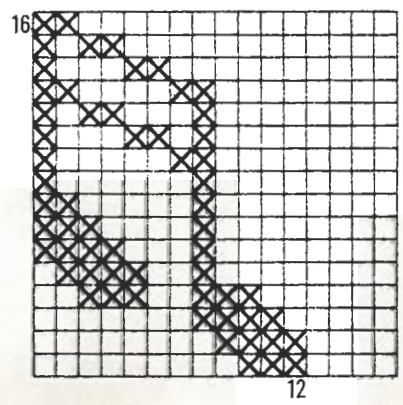
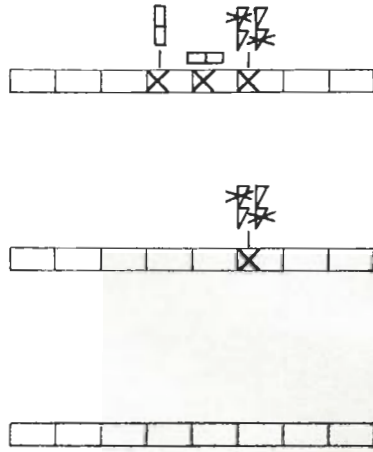
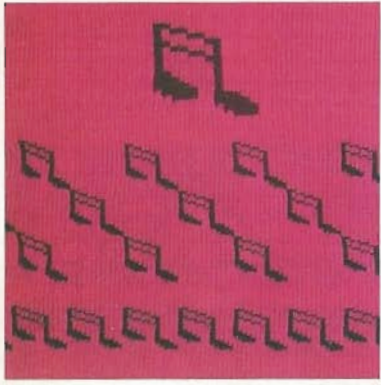

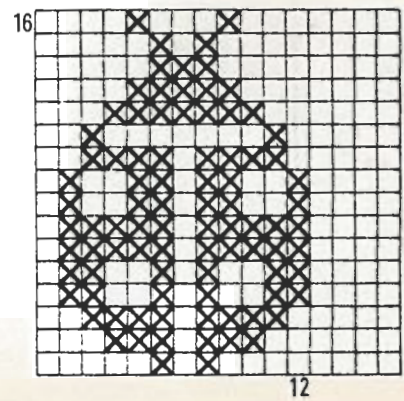
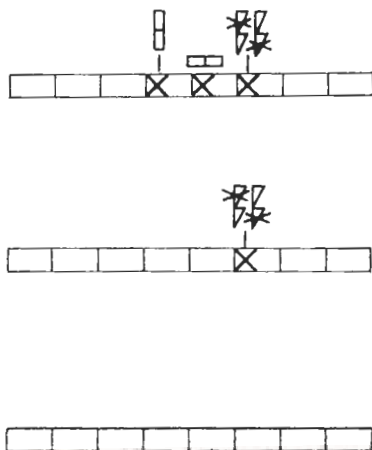
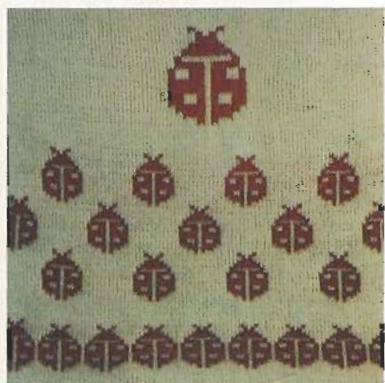
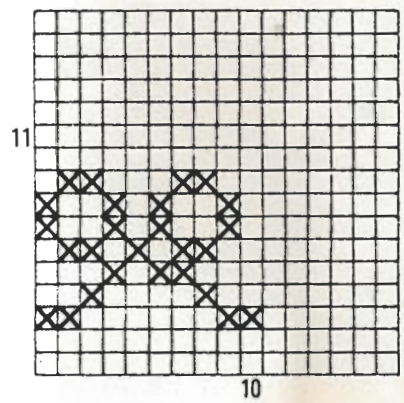
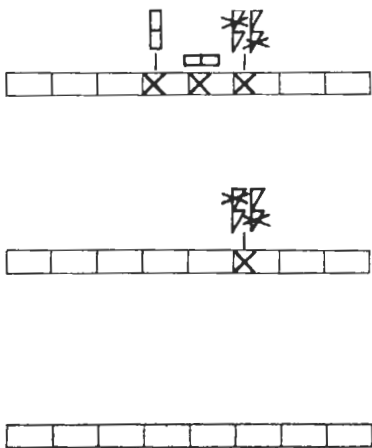
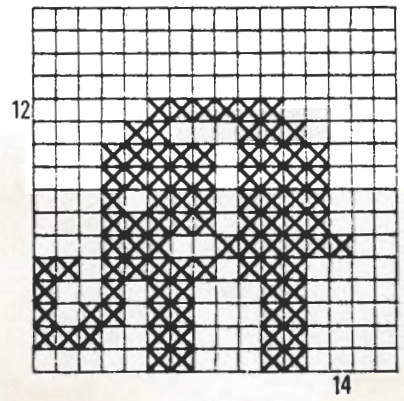
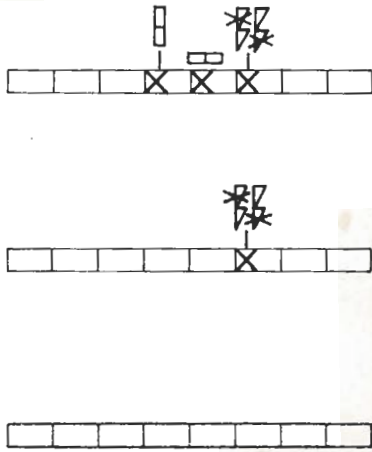

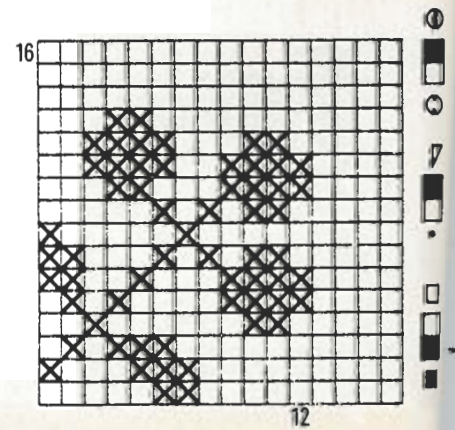
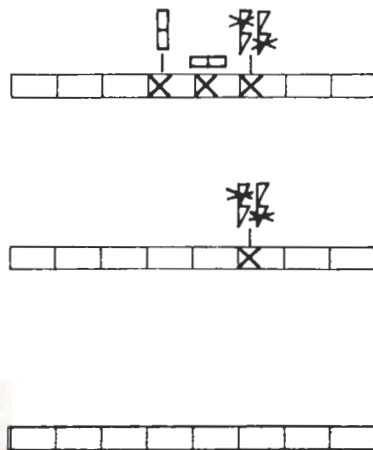
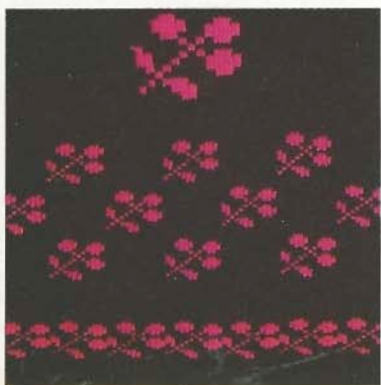
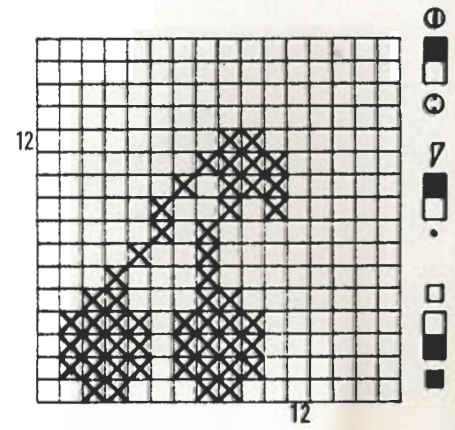
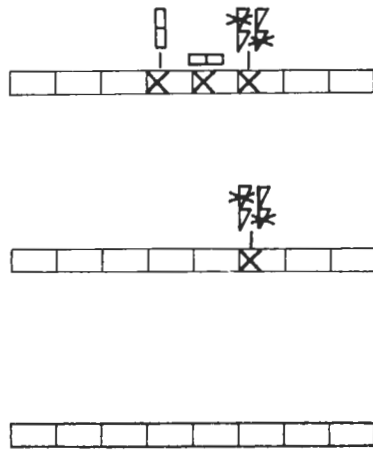
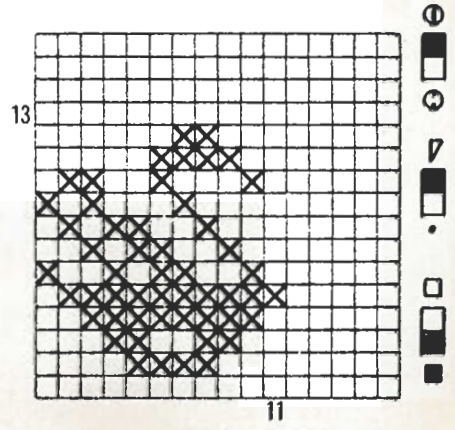
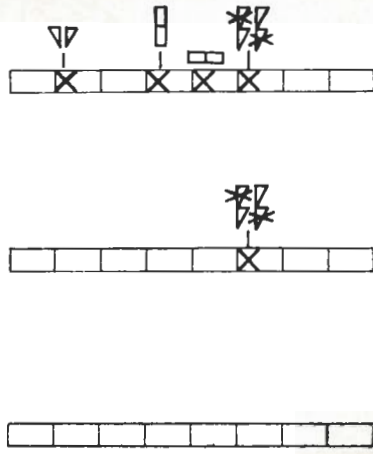

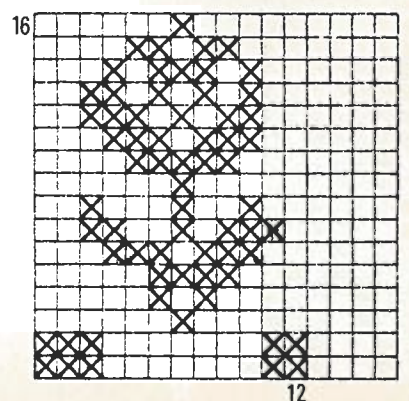
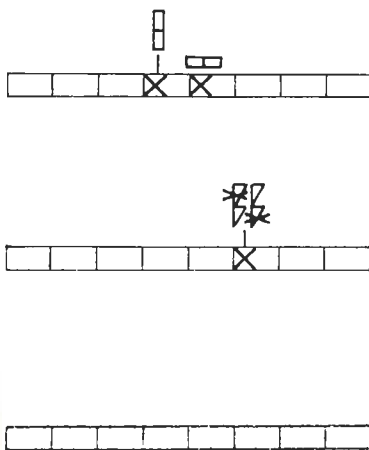
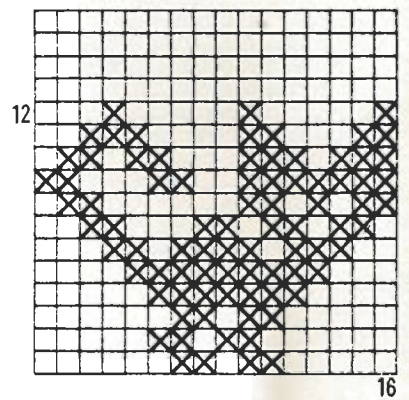
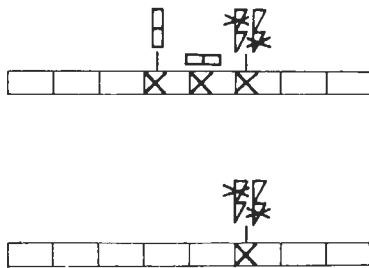
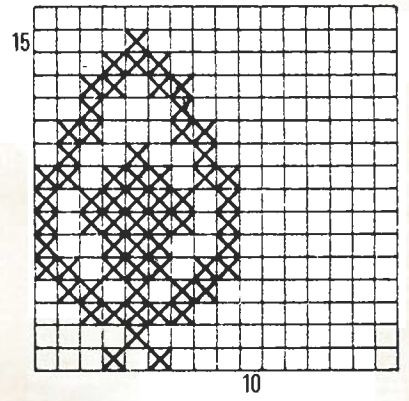
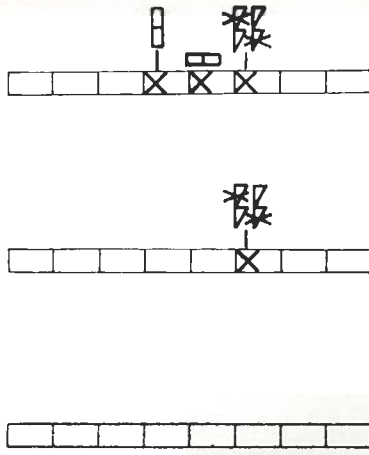

WEAVING EFFECT (VIII)

