

INSTRUCTION
BOOK



The
GOLDEN FLEECE
KNITTING MACHINE

INSTRUCTION BOOK AND GUIDE

FOR THE

GOLDEN FLEECE

KNITTING MACHINE.

IMPORTANT.

Read the paragraph on Page 8, headed "Unpacking the Machine," so that when the case containing the machine and its accessories reaches you none of the parts will be damaged in unpacking.

Keep the machine well oiled (see page 25).

Hold work firmly down and use buckle and weights provided. Always see that the latches of the raised needles are down before commencing to turn the handle.

Do not attempt to alter the various adjustments until you are fully informed of their uses.

When returning parts of machines for repairs, place your name and address on the parcel as well as inside, so that we may know from whom the parts are sent.

When ordering Needles, send a sample.

You are cordially invited to visit our TUITION PARLOURS

at our head office or Provincial Branches. The map below shows the location of our premises, which are easily accessible from any part of London. We also show how to reach our address by train, 'bus or tram.

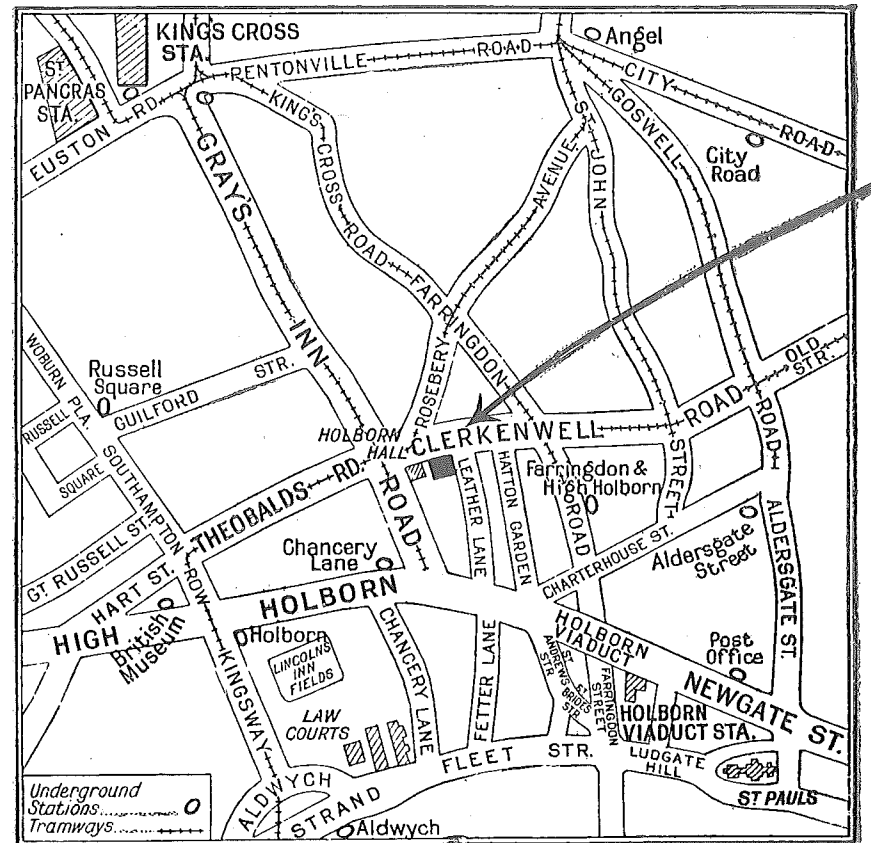

Our Offices and Tuition Parlours are on the south side of Clerkenwell Road, about one hundred yards East of Holborn Hall, which is at the junction of Clerkenwell Road and Gray's Inn Road. As the map shows, it is very near the top of Hatton Garden and Leather Lane, and also close to the lower end of Rosebery Avenue.

The nearest Railway Station is Farringdon Street Station, which, being on the Inner Circle of the Metropolitan Railway, is easily reached from any part of London. From the big terminal stations the visitor can reach Holborn Hall by the following 'buses and trams:—London Bridge, No. 18 Bus; Charing Cross, No. 35 L.C.C. Tram; Waterloo, No. 67 Bus; Victoria, No. 38 Bus; Marylebone, Baker St., Euston, St. Pancras, King's Cross, No. 18 Bus. From Liverpool Street or Paddington, the best route is by Underground to Farringdon Street Station. Buses that pass Holborn Hall are Nos. 18, 19, 38, 38B, 45, 67. Trams passing Holborn Hall are Nos. 3, 7, 21, 35, 43, 51, 55, 59, 65, 75, 81.

The Golden Fleece Knitting Machine

THE Golden Fleece Knitting Machine is not difficult to operate. The purpose of this instruction book is to teach novices how to operate it, and, by carefully following the instructions given in the pages that follow, any purchaser of a machine may become an expert knitter.

* * * *

At the same time it must be recognised that personal tuition is much better than instruction from a book and brings efficiency much more quickly. For that reason the learner is urged to take advantage, if possible, of the personal instruction obtainable in our Tuition Parlours at 91, Clerkenwell Road, London, E.C.1., or at any of our Provincial Branches. Every purchaser of a machine is offered the advantages of free personal tuition by expert instructors. As much progress towards proficiency can be made in one hour under a personal expert as by ten hours study of a printed book, however clearly the latter may be written.

* * * *

On the preceding page a map of a section of London is shown and from this map the reader will be able to see the most convenient route to the offices and tuition parlours of the Company.

* * * *

Those purchasers who, by reason of distance, are unable to take advantage of the personal tuition offered can learn from this Instruction Book, and in case of any special difficulty arising they are invited to write to the Company stating as clearly as they can the difficulty with which they are faced, and the Company will give them personal advice and explanation by letter. No charge is made for this service.

THE SOUTH BRITISH MANUFACTURING COMPANY, LTD.,
91, 93, 95 and 97, Clerkenwell Road, London, E.C.1.
and Provincial Branches.

Preliminary Remarks.

When you receive the machine please follow carefully the instructions given on page 8 regarding unpacking and fitting it up.

You will notice that the machine contains a half-knitted sock. That work has, of course, been done on the individual machine sent you. You can do equally good work, and, as you gain practice, much more elaborate work.

Please note that the best way to turn out socks is to do sock after sock without taking the work off the machine. It is not necessary—or even desirable—to cast off. After finishing one sock you simply knit about two inches with any odd wool or cotton and then proceed with the next sock, and so on. Then afterwards the socks are cut apart and the toes sewn up, as shown on page 14. This method of working saves you all the trouble of casting on new work, but if, for any reason, you take the work off the machine you can always cast on new work by using the tool called the “setter-up” as instructed on page 16.

Special Points to Remember ALL THE TIME.

The most important thing is to see that the needles are working properly. The needle latches (see page 8 for explanation) must rise and fall automatically—as the machine is worked. A stiff latch means a dropped stitch, and one dropped stitch will spoil a sock. Therefore, if a needle has a stiff latch replace it with a fresh needle. The stiff latch may be made to work freely by applying a little oil. If this fails to make it work freely, throw the needle away as useless. If used properly, needles will last for years.

Don't try to make too rapid progress in learning the machine. Learn one point thoroughly and practice it until you are perfect before proceeding to learn anything more advanced. Learn plain knitting thoroughly before trying ribbed knitting.

Don't play with the machine and turn the handle when there is no work in it. It may not matter, but, on the other hand, it may, and there is no reason to invite trouble. Don't let children play with the machine. To do so is not good for the machine and may be bad for the children.

The work in the machine must always be pulled down hard so that the stitches are as close to the top of the cylinder as possible. The weights are intended to pull down the work, but you must help with your left hand as you turn the handle with your right hand. And keep your eyes always open for stitches that are not properly down and push or pull them down. This caution is necessary only at the beginning. With a little practice you become alive to the need for keeping the stitches down and then you see that they are down without special effort.

The importance of the two points—seeing that the needle latches are working properly, and seeing that the work is pulled down hard—justify the emphasis placed upon them here. Remember these two points always and you will save yourself a lot of trouble.

The Principal Parts of the Machine.

The following description of the Golden Fleece Knitting Machine should be read through by the learner, but need not be committed to memory. So long as she understands the main parts of the machine and their purpose, a knowledge of others will come in practice as she gets used to the machine. Please study the illustrations of the machine on pages 6 and 7 as you read, so that you understand from the letters on the illustrations the part indicated.

- (A) Two thumb screws by means of which the machine is made secure to a table or bench.
- (B) Crank wheel with handle which is turned to operate the machine.
- (C) Counting Dial which indicates the number of revolutions. If, for instance, the leg of a sock requires 80 knitted rows before beginning to work the heel, the counting dial will show when the number has been reached without the need for counting the revolutions as they are made.
- (D) This part is called the Cam Shell, and the turning of the handle (B) moves it round the needle cylinder.
- (E) Needle cylinder which contains the needles. It does not move at all. The machine knits through the action of the Cam Shell (D) moving around the needle cylinder (E).
- (F) Yarn Carrier which travels round the needle cylinder as the machine is operated and feeds the yarn to the needles.
- (G) Buckle which grips the work being done and by carrying the weight holder and weights enables the stitches on the needles to be pulled down close to the top edge of the needle cylinder.
- (H) Bobbin containing the wool which has to be wound on it from the hank by the help of the bobbin winder (see page 18).
- (J) Yarn Stand Rod whose function is to support yarn stand top (K).
- (K) Yarn Stand Top with three arms each fitted with eyes. The yarn on its way from the bobbin (H) to the yarn carrier (F) passes through the yarn stand top (K) (see page 9 for proper method of threading the yarn).
- (L) Tension Screw, the turning of which makes the stitches longer or shorter, as desired, in accordance with the class of work being knitted. Read carefully the note on page 26.

The next three parts are parts of the ribbing attachment—which knits the purl stitches—and the learner is advised to ignore them until she has mastered the art of plain knitting.

- (M) Ribber Arm which carries the ribber dial (N). The ribber arm with the attached dial need not be inserted in the machine unless ribbing work is being done. Note however that plain work can be done even if the ribbing attachment is in position; in such case, the Ribber Needles will not be required.
- (N) Ribber Needle Dial or Horizontal Disc which carries the ribbing needles that do the "purl" stitches when the machine is doing ribbed work.
- (O) Tappet Plate, which is part of the ribber mechanism and contains the cams by means of which the ribber needles are controlled.
- (P) Dial Adjuster, for regulating Ribber Post, as explained on page 21.

For detailed instructions regarding the Ribbing Attachment please see pages 20 to 24.

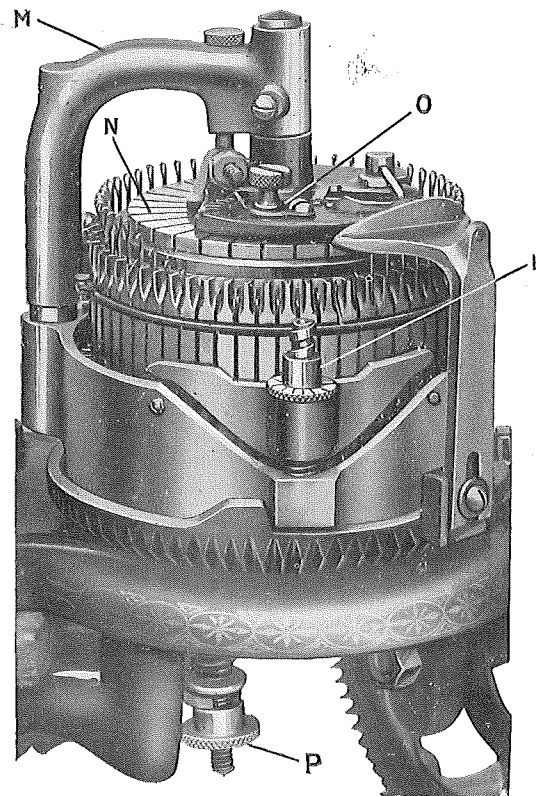

This illustration gives a view of parts of the Machine that are not seen clearly in the illustration on the next page.

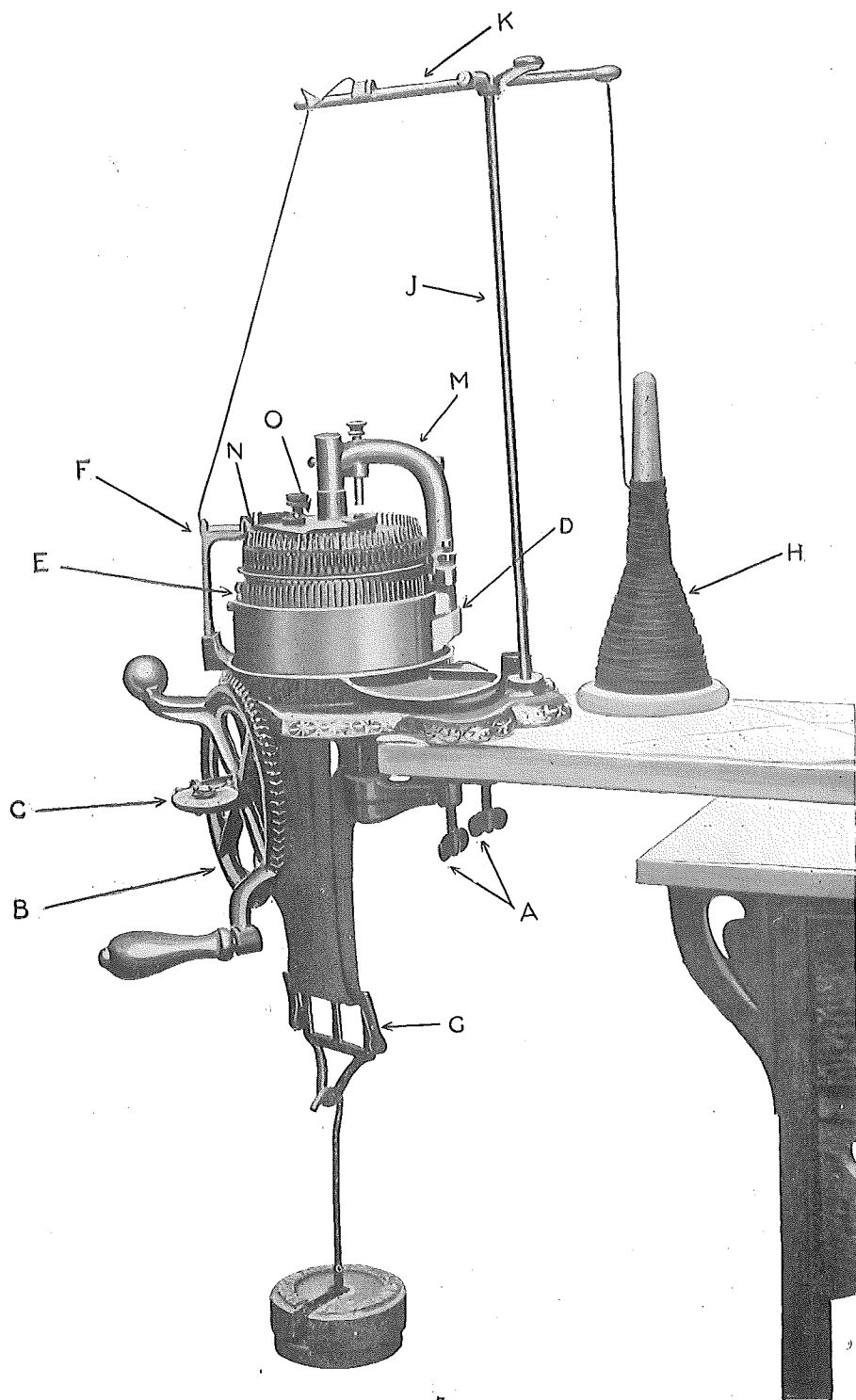

The NEEDLES of the machine are not shown large enough in the illustration on pages 6 and 7, so a drawing of a needle is reproduced here. The little hinged bar is called the Latch. It should rise and fall very freely as the machine is worked, and if the latch does not rise and fall freely, good work cannot be done. A stiff latch should be oiled (see page 25), but if oiling does not make it work freely the needle latch is probably bent and if this cannot be straightened the needle should be discarded and a new one put in its place.

Unpacking the Machine.

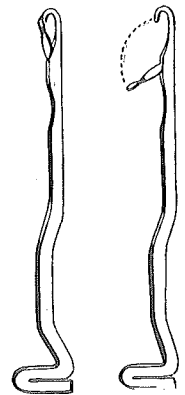

Do this carefully so as not to damage any part of the machine, particularly the needles. Place the packing case containing the machine on a table with the lid downwards, so that the address label bearing your name and address is touching the table. Now take off the bottom of the box. Remove the packing material and any loose parts, such as the weights, that you can reach conveniently. When this has been done turn the box right side up and remove the lid. Take out all the loose parts and accessories that remain and also the rest of the packing material. All that now remains in the lidless and bottomless box is the main part of the machine which is secured to a crosspiece of wood so as to keep it firm during transit.

Now you undo the clamp screws (A, page 7) take out the machine and fix it by its clamp screws to a table or bench. You will find that the half-knitted sock on the machine has its loose end tied to the crank wheel (B, page 7) so as to keep the stitches on the needles. Cut the string tying the work to the crank wheel and then attach the buckle (C, page 7) to the work and suspend the weight rod and weight from the buckle. The buckle will slide on to the work with the weight-holder end uppermost; then turn this end down and attach weights.

Do Not Turn the Handle Yet.

Fix the Yarn Stand Rod in its place (J, page 7) and then put on and tighten into position the Yarn Stand Top (K, page 7). Use the screwdriver in doing this, and note carefully that the correct position for the Yarn Stand Top is with the longest of the three arms right over the centre of the needle cylinder, as seen on page 7. The bobbin carrying the yarn is placed directly under the eye of either of the shorter arms so that the yarn will run off freely. Now thread the yarn through the Yarn Stand Top. There are several wrong ways to do this but one right way.

Take hold of the end of the yarn on the spool and thread it through the eye of either of the short arms of the top. Now thread it through the horizontal eye in the long arm under the copper wire

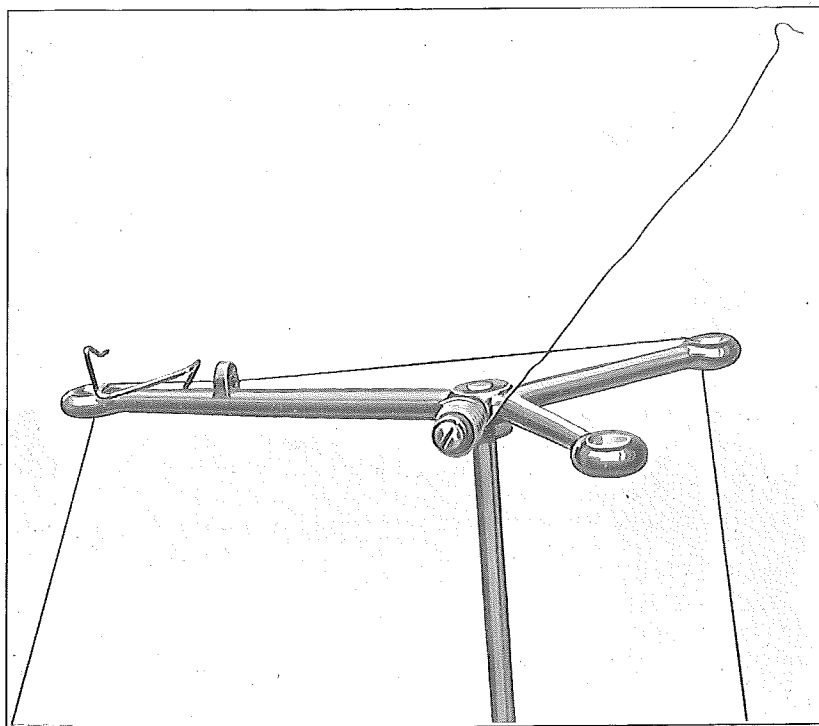

The Right Way to Thread the Yarn (Top).

hook and down through the eye at the end of the long arm. You ignore the long thin wire spring in the meantime as it is only called into action in making heels and toes and its use will be explained later.

You have now got the yarn threaded through the Yarn Stand Top. Now thread the end through the Yarn Carrier (F, page 7, or seen in better detail in the illustration on page 16.) Now tie the free end of yarn to the free end of yarn from the half knitted sock in the machine, making as small a knot as possible and making it as near the work on the machine as possible.

See that all the latches of the needles are *down*. If a single latch is up, the needle will not take the thread and there will be a slipped stitch. Therefore—the instruction is worth repeating—see that all the latches of the needles are down. If you find that any needle latch is up because it is too stiff to fall down freely you must remedy the defect or remove the needle and put in a new needle. But in any event you must make sure that all the needle latches work freely and that you start work with all the latches down.

See that the weights are pulling the work well down on the needles. This is important. The stitches should be just as far down on the needles as they can go—right down to the top of the cylinder rim. Pull the weights down hard so as to get the stitches right down and if necessary push the actual stitches down with the fingers but **SEE THAT THE STITCHES ARE PROPERLY DOWN.**

Now with your right hand on the handle get ready to turn the handle to operate the machine. Before actually beginning to turn give a last look to see that your stitches are properly down. Then turn slowly, noticing that the Yarn Carrier is feeding the yarn into the needles as it goes past them on its revolution.

As you turn the handle the Cam Shell (D, page 7) will move round the needle cylinder and the needles will sink down into the cylinder well, pulling the strand of yarn through the former stitches and making new stitches. As you see this happen you will begin to enjoy the fascination of knitting by machine—you will see how beautifully the Golden Fleece Knitting Machine does its work. If the work seems all right keep on turning the handle, but still turn slowly seeing all the time that the pull of the weights, assisted if necessary by hand pulling, keeps the stitches down to the rim of the cylinder. This is also very important.

Watch Carefully the Stitches as they are Formed.

If you find that any stitch comes off the needle, replace it on the needle by using the work hook, so that when the yarn is carried round for the next row, the stitch will be there to receive the yarn. If you find that the new thread of yarn has not made a stitch, but has simply helped to fill up the needle head, you may look for a stiff latch and remedy the stiffness or put in a new needle.

So, keeping on turning the handle, watching all the while that the new stitches are being properly formed, seeing that the latches are working properly and that the work is being pulled well down, you can increase your speed, turning more and more rapidly. If the knitted web is coming properly without a faulty stitch, and with no dropped stitches, you have the satisfaction of knowing that you have mastered the art of plain knitting on the Golden Fleece Knitting Machine.

At this stage it does not really matter whether you make a good sock or not. The first thing is not to make a sock—it is to knit, to gain acquaintance with the machine, to know how to remedy anything wrong as it happens. And always remember that if anything does go wrong, it is simply due to your lack of experience and through your not knowing quite what to do. Do not be discouraged if your first effort does not seem to be successful. Try again and before doing so read once again and very carefully the instructions given above. A little practice will give you perfection and you may be quite sure that perfect socks and more elaborate work than socks are being made to-day by thousands of women who imagined because they did not make perfect work in the first

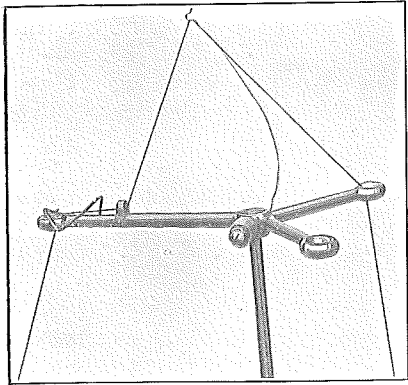

The Wrong Way.

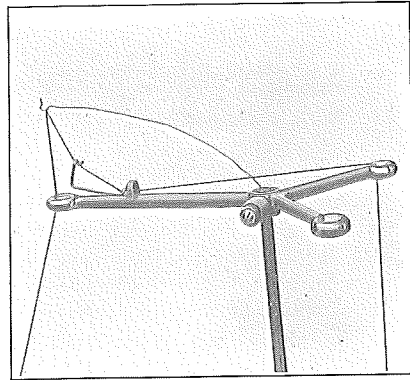

The Right Way.

half-hour that the machine was too difficult to operate or that they were too stupid ever to learn it properly. A little perseverance and confidence at this stage will help you wonderfully.

Beginning the Heel.

Assuming that you have got on well up to this point and are knitting a good sock web, you now want to progress further and make the heel. This is how you do it. First see that the yarn carrier (F page 7) is in front of the machine. On the outside of the needle cylinder you will find two red spots, one at each side directly opposite each other. From one spot to the other is exactly half the cylinder and therefore half the needles. Pull up with your fingers or push up with the little crescent-shaped tool called the Crescent all the needles round the back of the Cylinder from one red spot to the other red spot. By doing this you put these needles out of action because you have raised them where the Cam cannot act upon them as it revolves round the Cylinder. Now, using your fingers, loop the yarn in the yarn top into the loop of the Heel Spring. There is a wrong way to do it and a right way to do it. Do it the right way—the picture shows you how.

Half of the needles are now out of action and only the front half will knit when you work the machine. Pull the work down

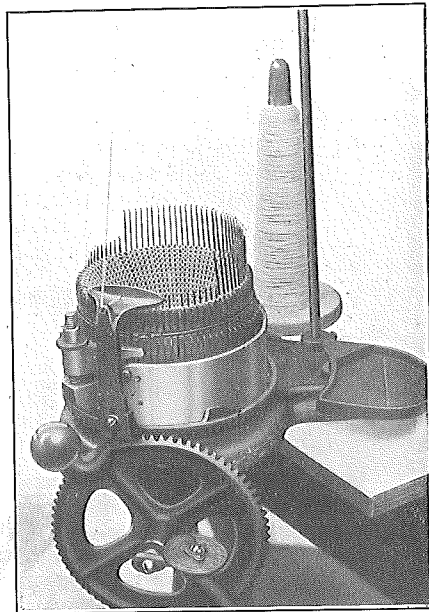

by hand at the front side which is the side where the heel is to be made. Turn the handle until the yarn carrier has made about half a turn when it will be just in front of the Yarn Stand (page 7) then stop. At this point the Cam has cleared the last needle in action. Now raise out of action the last needle on the right of those still in action. Now turn the handle backwards and the machine will make a row of stitches working to the left instead of, as formerly, to the right. Now you see the purpose of the long Heel Spring on the Yarn Stand Top. It pulls up the slack as you reverse the motion and enables the Yarn Carrier to feed the needles properly. In turning the handle backwards, as instructed above, see that you do so until the Yarn Carrier is opposite the Yarn Stand so that the Cam will have cleared the last needle in action on the left. Now raise out of action the last needle on the left and knit one row to the right again as before. Raise the next needle furthest to the right and knit another row backwards, raise out of action the needle in action furthest to the left and knit a row forwards; and so on, raising one needle out of action every time you reverse the direction of your knitting and going from left to right and then from right to left. Keep on pulling the work down with the left hand all the time and see that the first and last stitches in each row knit properly. Keep on knitting from right to left and left to right, as instructed above, until only ten needles are left in action. The last needle you pull up will be a left-hand needle. The last course you knit will be work to the right.

The Second Part of the Heel.

That is the first part of the heel done. Before proceeding with the second part you take the heel hook and putting it inside the work, hook it into the work, one hook being at each end of the ten stitches. Then taking the weights and weight hook off the buckle, hang them on the loop of the heel hook. Now with your fingers press down into action the first of the out-of-action needles on the right, **LIFT THE YARN FROM THE FRONT OF THIS NEEDLE TO THE BACK.** This is important. If you do not do so the finished heel will have holes in it. See that the latch of this needle is down, and, turning the handle backwards, knit one row to the left. Now press down into action the first of the out-of-action needles on the left, lift the yarn behind it, making sure that the latch is down and knit one row to the right. Repeat the process, needle down, yarn round, latch open, knit to left; needle down, yarn round, latch open, knit to right; and so on, backwards and forwards until only one needle at each side of the machine is still raised out of action. Now press down the last needle on the right side, as well as the one beyond the red mark,

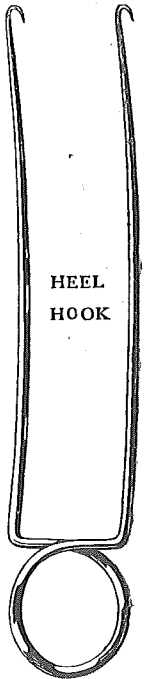

put yarn round both needles, raise the needle beyond the red mark, and knit to the left; repeat this on the left side, turn handle until the Yarn Carrier is in front of the machine and then press down into action all the needles that are still up out of action, take the wool out of the Heel Spring Loop, examine all needles to see that all the latches are down and turn the handle to the right again and keep on turning until you have knitted the length of the foot just as you knitted the leg. When you have done all this you are ready to make the toe.

Making the Toe.

To make the toe, follow the instructions given for the first stage of the heel. In order to be as simple and explicit as possible, we shall repeat the instructions. First see that the Yarn Carrier is in front of the machine. Pull up out of action half the needles exactly as you did for the heel. These will be the half at the back of the machine, between the two red spots on the sides. Loop the yarn into the Heel Spring. Don't forget, as you proceed, to see that the work is pulled down well and that the latches are open. Turn the handle until the Yarn Carrier is at the back of the machine in front of the Yarn Stand. Raise out of action the last needle on the right of those in action. Turn the handle backwards until the Yarn Carrier has made one round, and the Cam has cleared the last needle in action on the left. Raise out of action the last needle on the left. Knit forwards one row; raise out of action the last needle in action on the right, then knit backwards one row; keep on doing this until only ten needles are left down, but see that the last needle you pull up is on the left hand side of the machine.

When you have done all this, the Yarn Carrier will be at the back of the machine. You go on to do the second part of the toe exactly as you made the second part of the heel and again we shall repeat the instructions. With your fingers press down into action the first of the out-of-action needles on the right. Lift the yarn from the front of this needle to the back, see that the latch of this needle is down and, turning the handle backwards, knit one row to the left. Now press down into action the first of the out-of-action needles on the left, lift the yarn behind it, making sure that the latch is down, and knit one row to the right. Repeat the process, needle down, yarn round, latch open, knit to left; needle down, yarn round, latch open, knit to right; and so on, backwards and forwards until only one needle at each side of the machine is still raised out of action. Now press down the last needle on the left side, turn the handle forwards until the yarn carrier is in front of the machine, and then press down into action all the needles that are still out of action. Take the wool out of the Heel Spring Loop, examine all the needles to see that all the latches are down and, turning the handle to the right again, knit four rows.

When you have got thus far you have finished the machine work of the sock and all that remains to be done is to sew up the toe in the manner described below, but do not take the work out of the machine. It would be easy to do so. All that you have to do is to break the wool at the yarn carrier, turn the handle to the right and in one turn the work is free from the needles and ready to have the toe sewn up. But it is much better to keep the work on the machine and knit one length of many socks. Then you can cut the individual socks apart and sew up the toes of each of them. We shall see how to do that later, but meantime let us go on knitting another sock.

It is usual and useful to knit about two inches of circular web between each sock and its successor, and, in cutting apart, these two inches are, of course, simply waste. These two inches may be knitted of the same wool as you are using for the sock itself or you can use any odd wool of any colour for this two inches. Indeed, it is better to use odd wool of a different colour because then you can easily see which part of the work is sock and which part joining web.

Let us suppose that you have a few yards of wool of a different colour from the actual work. Break the wool close above the yarn holder and tie to the work end of the broken wool the end of the different coloured wool, making the knot as small as possible so that it will go through the yarn holder very easily. Having done this, knit on as before, turning the handle until you have knitted about two inches of webbing. Now break the yarn again and tie on to the work end the end of the sock yarn and begin another sock going through all the operations already gone through. Then when you have knitted a second sock, go on with another two inches of joining web with any odd piece of wool and then on to another sock.

Sewing up the Toe.

That completes the instructions for making a plain unribbed sock. Before proceeding to study the working of the ribber, we can see how to sew up the toes so as to make the finished socks.

Let us assume that you have a sock and wish to sew up the toe properly. The sock has either been taken from the machine after the sock was finished or it has been cut from the web by cutting through the joining web already described. In either case the toe should be laid flat, placed under a damp cloth and pressed with a hot iron. This makes the stitches firmer and less likely to run down. Having done this, rove back the four rows you knitted in following the instructions given above and this will take you back to where there is a small hole at each side of the toe where the actual finish was. These two holes guide you in stopping roving back.

Now you sew up the toe by hand, using an ordinary darning needle. For practice purposes at first it is good to use thread of a different colour, preferably darker, from the wool of the work. This enables you to see better if your stitches are just right. The

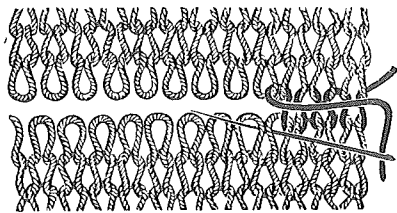

illustration herewith shows you exactly how to make the stitches that join the two sides of the toe-opening left by the machine. We can supplement the illustration by a few sentences to make it more clear if possible.

You will notice that each stitch has the needle passed through it twice. First the needle is put in through the first stitch and out through the second one on the same side—then in through the first one and through the second one on the opposite side—again through the second stitch and out through the third stitch on the first side and so on until the opening has been properly sewn up. If properly done with wool of the same colour as the sock itself, it will be impossible to distinguish it from the actual knitting, especially if care has been taken to make the stitches sewn neither slacker nor tighter than the stitches of the knitting.

The sock is now finished. It may be pressed if you like and the pressing is done by using an iron, not too hot, so as not to scorch the wool—and then if you propose to send the socks to shops to be sold they can be tied with tape into bundles of one dozen, making a half a dozen pairs in each bundle.

Putting the Work on the Machine Again.

All the foregoing instruction has been straightforward and we have assumed that everything has gone well with the learner in her progress so far. But there is one thing she must know something about and perhaps she has had occasion for the knowledge before she has finished her first sock. It may be that through the breaking of the yarn or for any other reason the work has come off the machine leaving the needles empty. What is she to do in such circumstances? We have already explained that the best practice is never to take the work off the machine but to knit sock after sock. And the expert has no difficulty in doing this. But the novice may have contrived to get the work off the machine unintentionally and wants to put it on again.

Before trying to get the stitches on the needles again, put the sock down flat on a table, put a damp cloth over it and press it with a hot iron—not too hot because you do not want to scorch it. This will make the stitches flat and firm. Unravel a row or two so that you get an even edge of flat firm stitches. Now with the little tool called the “work hook” you can put the stitches over the needles one by one until the whole sock is on the machine again. Then having joined up the yarn again if it has been broken



WORK HOOK.

you can go on knitting as before but don't forget the two important essentials—see that the needles are working freely and that the work is pulled down hard all the time. Never forget these two points.

Casting on New Work.

Now, let us consider the procedure of casting on new work. Suppose there is no work on the machine and you wish to start a sock. To do this, you use the tool called the “setter-up,” which is a circular arrangement consisting of a great number of wire teeth bent near the points. Look at the photograph below showing the “setter-up” in use. You hold the tool from below inside the cylinder and the teeth come up to a position just below the edge of the cylinder rim.

Having pulled the yarn through the two holes in the yarn carrier you continue to pull until you have a yard or a yard and a half of yarn through. Now get the yarn carrier right in front of you, on the side of the cylinder nearest to you. Turn the handle to the right so that the yarn carrier passes a dozen or fifteen needles, keeping the yarn from engaging the needles. Now turn the handle

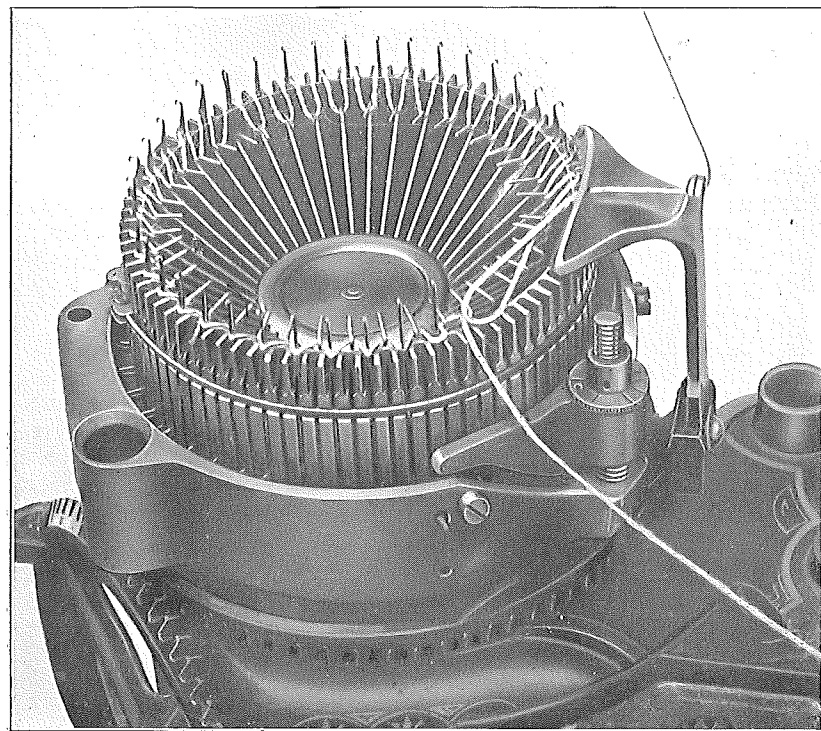

back again until the yarn carrier is in its original position—right in front of you. The position is now that the needles are depressed in front of the yarn carrier and a little way to the right of it. Begin with the first needle on the right that is not depressed. Hook the yarn round that needle and then round the nearest hook of the “setter-up”—then round the next needle and then round one of the teeth of the “setter-up.” Keep on doing this until you have gone as far as you can go round the cylinder and have come to the last needle on the left that is not depressed. If the “setter-up” has not so many teeth as there are needles that does not matter at all. One “setter-up” hook can serve more than one needle and although some of the “setter-up” hooks have two or more loops on each because they serve more than one needle that will be quite all right.

Now you have got looping done three quarters way round or a little more. Turn the handle slowly forward, allowing the yarn carrier to feed the yarn into the needles from where you first looped up, and turn slowly until the yarn carrier has gone about quarter way round the cylinder. The effect is to raise into feeding position all the needles that were depressed by the cam and you can now complete the looping of the needles and “setter-up” teeth. When you have done this every needle has some yarn around it. Turn the handle slowly keeping a watch for any needle latch that is not working properly. Keep on turning slowly and the web will begin to form under your eyes. If any stitches are missed or slip off, loop the yarn opposite the needle over the needle. Pull down the work well so that the needles are properly fed and the stitches properly formed. Now hang the weight hook and weights on to the end of the “setter-up.” Keep on turning, watching carefully for dropped stitches and making good any fault. If everything seems all right, increase your speed a little and the web will begin to get longer and longer. When it is long enough to be able to take the buckle, take off the “setter-up” and the weights, put on the buckle and the weight hook and weights and you have the work fairly going.

Regulating the Stitch.

Every Golden Fleece Knitting Machine is carefully adjusted before it is sent out and is ready to be worked. We have deferred till now giving any indication of the purpose and manipulation of a very important part of the mechanism—the Tension Screw. This is the milled brass screw in front of the Cam and is indicated by the letter L in the illustration on page 6. This screw can be raised or lowered. When raised the tension is tight and shorter stitches are made. If lowered, slack tension or longer stitches result. If the screw be too high, the stitches are too short and the needles fail to work, and the wool is merely carried round the machine without stitches being made. If the screw is a little stiff to move you can use a pair of pliers to assist you. And while moving the screw with your thumb and forefinger of the right hand or by

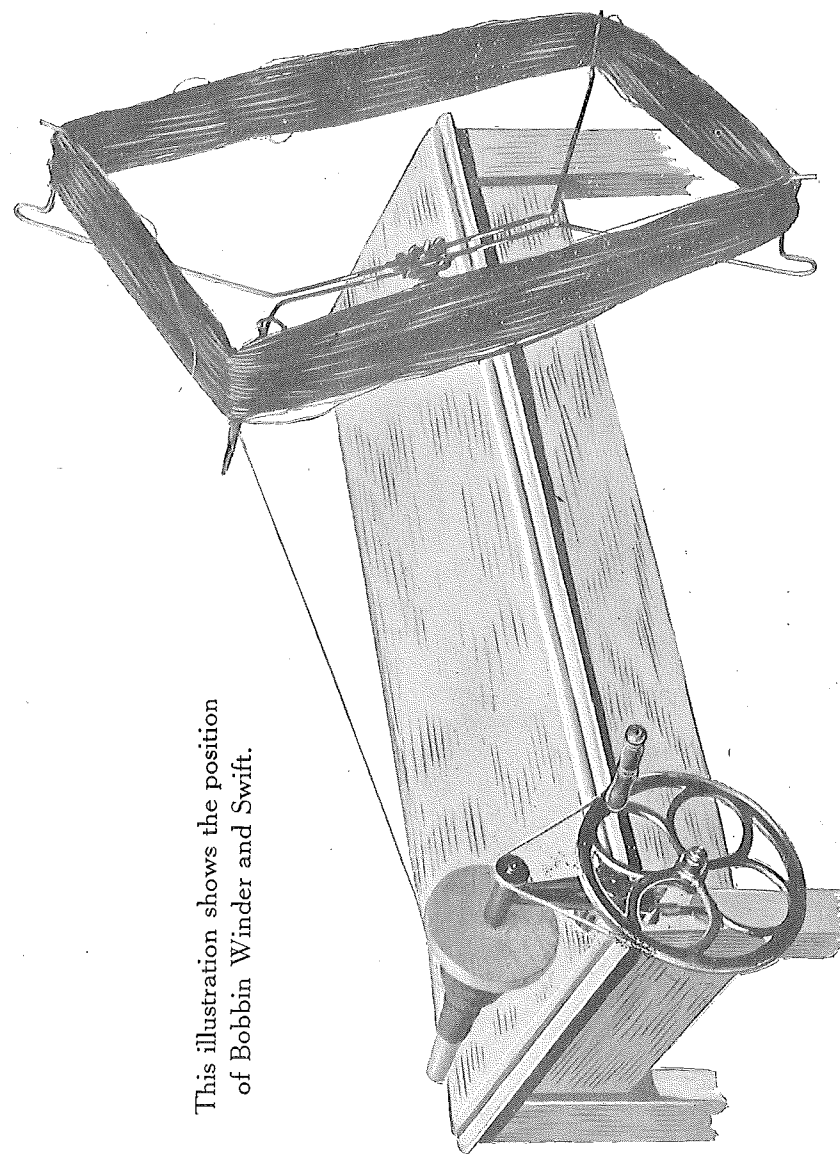

This illustration shows the position of Bobbin Winder and Swift.

using a pair of pliers in the right hand you may if you like press down the cam with the fingers of the left hand and thus make it a little easier to turn the screw. You will notice that the tension screw has numbers stamped on it. By a little experience and practise you can set the screw so that you get the length of stitch you want. To begin with, do not touch the Tension Screw. When you get the machine, the screw is in the right position for good average length of stitch. When you get used to the machine a little, you can loosen or tighten the tension screw and see the difference in length of stitch that you get by doing so. Thus you get to learn the particular tension that is just right for any particular class of work you have in hand.

Winding the Bobbins.

You buy the yarn in hanks and before using it on the machine you must wind it on the bobbin. The illustration indicates how this is done. The Winder is the attachment with the handle. You fix it to the edge of a table as shown in the picture and make it tight with the clamping screw. Push the bobbin on to the spindle. The wire arrangement is called the Swift. Fix it to the far end of the table as shown in the picture, and put the hank of yarn over the wires. Put a few turns of the yarn round the bobbin with your hand and then go on turning the handle of the winder. Guide the wool with the hand and wind firmly and evenly making the bobbin fullest at the bottom. A bobbin badly wound may make the machine work stiffly. With coarse wools it is a good plan to make the yarn going on the bobbin pass over some oiled wool which you can hold in your left hand. This makes the knitting easier on the machine, but light or fine wools should not be treated by this process as they would be spoiled by the oil.

Re-Footing.

Cut off the waste part and then press with a hot iron the work at the edge so as to make the stitches firm. Unravel a few rows of stitches so as to get an even row of stitches, which, after the ironing, will be fairly firm. Now put the work on the machine exactly as if the work had come off the machine. This has been explained on page 15. If the sock or stocking had more stitches than there are needles on the machine, you can put two stitches on one needle at regular intervals round the cylinders. Then you knit in the usual way until you come to the heel when you make the heel as already explained and then make the foot and the toe.

THE USE OF THE RIBBER.

Having learned plain knitting, the reader has now reached the stage when we may begin to understand and operate the Ribber. The Ribber, of course (see illustration below), is the attachment that enables the operator to knit purl stitches and thus make ribbed socks and stockings or ribbed flat work.

The Ribber when in use is placed with its disc inside the cylinder just at the top, as shown on page 7. When not in use the Ribber can be kept out of the way of the cylinder by having its supporting arm placed in the hole made to fit it on the back of the machine. There is no objection to having it in working position even if it is not in use at the moment, because it does not interfere with plain knitting, but it is generally more convenient to have it in the out-of-work position when only plain work is being done.

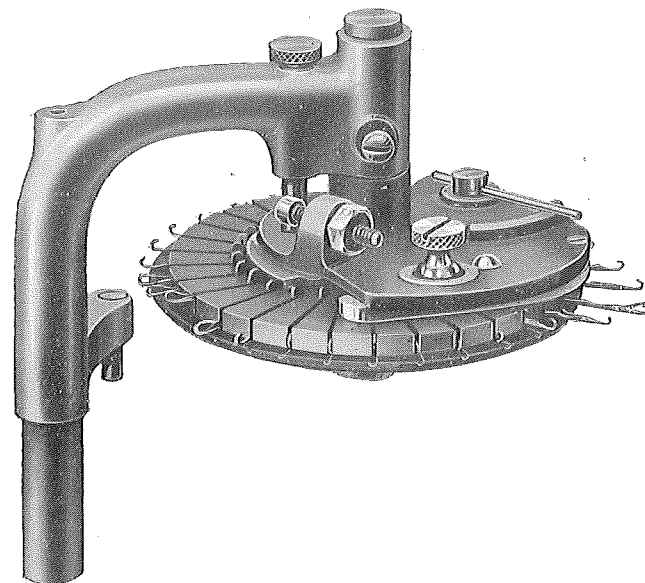

When you receive the machine the Ribber Dial (N, page 6) has no needles in it. You will find the needles in the small envelope tied to the Ribber Arm. The Ribber Dial is, of course, the circular plate with grooves for needles and is the main part of the Ribber. Note that the Ribber Needles are not identical with the Cylinder Needles. They are much shorter, and they work in their grooves horizontally instead of up and down vertically as the Cylinder Needles do.

Now for instruction regarding the Ribber. Fix the Ribber Arm on the Cam Cylinder, the two pins under the base of the Ribber Arm fitting into the two holes in the thick part of the Cam Cylinder, the Ribber Dial being over the centre of the Cylinder, as seen in the picture on page 6. The pins fit their holes quite tightly and they are meant to do so because the Ribber must be quite fixed in its place. If difficulty is found in getting the pins into their holes a touch of oil on the pins will help matters. Press the Ribber Arm down into its place until the point of the Ribber Arm Screw actually touches the top of the Cam Cylinder.

When the Ribber Arm has been well pressed home, turn the Dial as far as it will go in the direction in which the Yarn Carrier travels. When you have done this, the lug underneath the Ribber will press against the Ribber Post inside the Cylinder and it should continue to do so when it is being worked.

When you have got so far, notice if the grooves in the Ribber Dial are exactly central with the Cylinder Needles. This is very important. If the needles on the cylinder are not exactly opposite the centre of the Ribber Dial grooves you can adjust them by turning the Dial Adjuster (see illustration below), which is at the left-hand side of the machine under the Bed Plate. Every Ribber Dial sent out has been carefully adjusted, so probably you require to make no adjustment. The Dial Adjuster, when turned, operates on a lever inside the Cylinder close to the side, called the Ribber Post. You can turn the nut, which we have called the Dial Adjuster, to the right

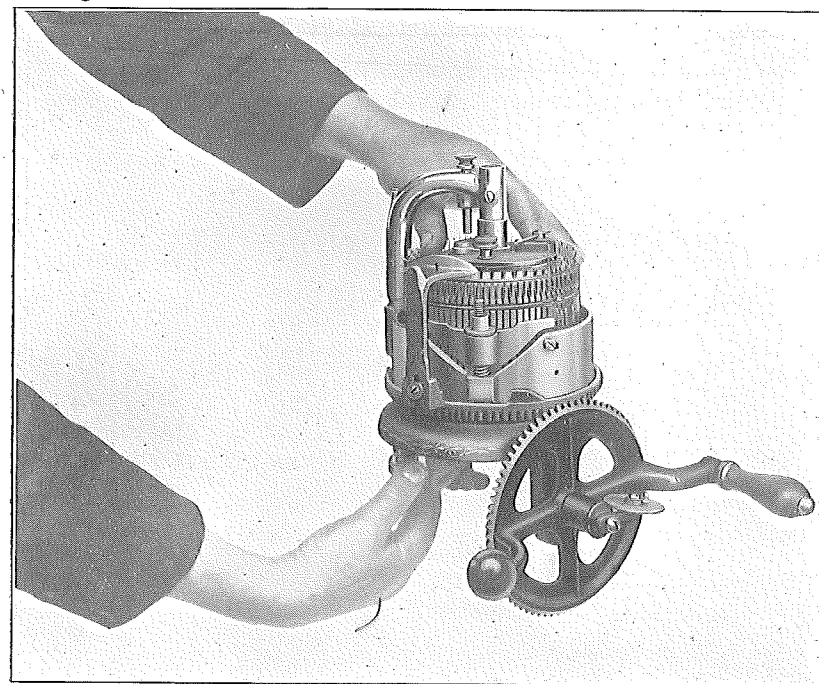
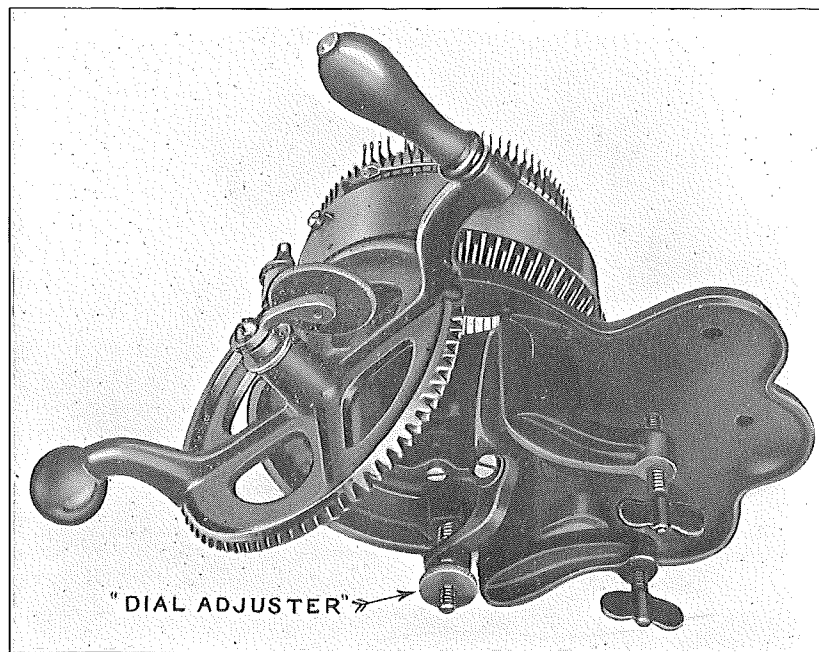

or to the left, as you find it necessary, in order to bring the Dial Grooves with their centres dead in line with the Cylinder Needles.

Having done this, hold the Dial firmly with one hand and turn the Tappet Plate (page 23) back in the opposite direction until the Time Screw (page 20) touches the Driving Pin.

Now we can place the needles in the Dial. You will notice that the Dial has exactly half the number of grooves that you find in the Cylinder. This means that if every groove in the Dial is fitted with a needle the work will be one purl, one plain—the closest ribbing you can get. Presently we shall see the different varieties of ribbing that can be done, but, meantime, we proceed with instruction on getting the Ribber to work.

Take off the clasp ring that circles the outside of the Cylinder. Bring the Yarn Carrier round to the front of the machine. Now take a Ribber Needle and open the latch. Hook this needle to a Cylinder Needle on the right hand side of the machine. The needle should be one which is opposite to one of the grooves in the dial. The stitch on the Cylinder Needle should be slid behind the Cylinder Latch and then forwards over the two needle hooks so that the stitch is now on the ribber needle, which can now be dropped into its groove on the Dial. The Cylinder Needle will of course be removed.

See that the Switch Pin (see illustration opposite) is at the

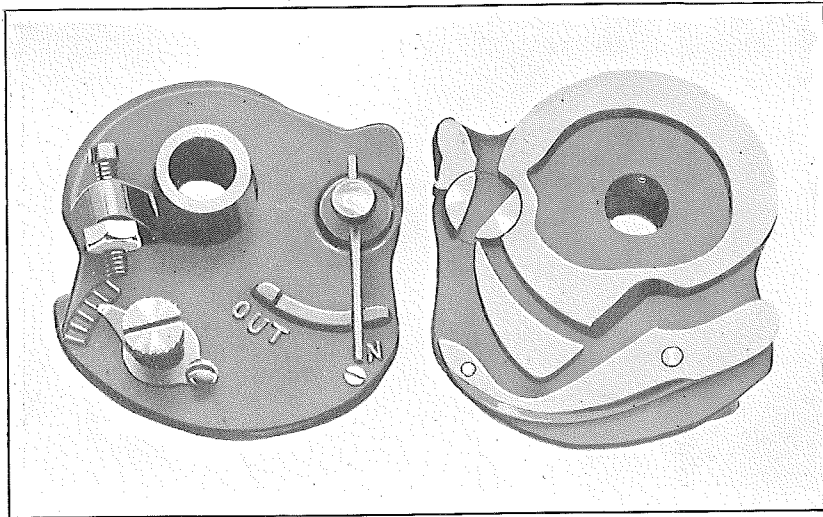

position marked IN and move the Tappet Plate forward gradually and thus make way for the rest of the needles by turning the Crank Wheel forward, taking care to pull the work down firmly so that the Cylinder Needles will continue to knit. Now we have got all the Ribber Needles in their grooves, and we shall assume that we have a piece of plain work on the machine and that we propose to change the pattern to ribbed work—one purl and one plain. Each Ribber Needle is now opposite a Cylinder Needle, but every

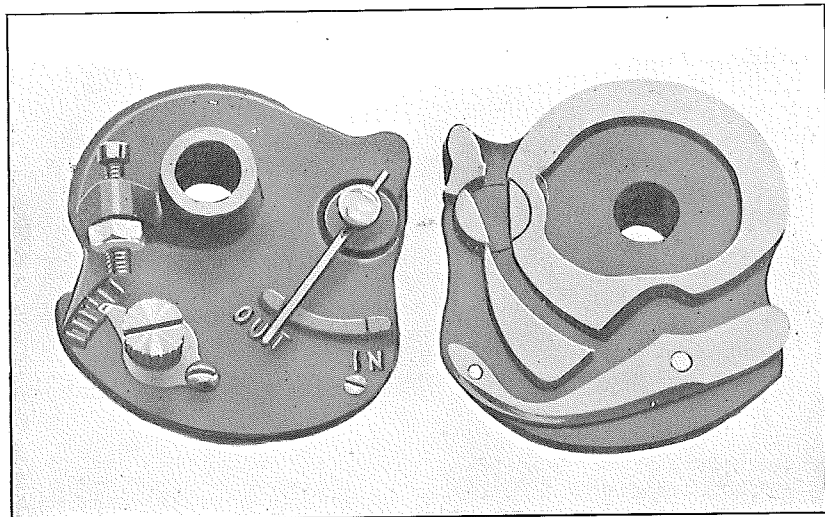

alternate Cylinder Needle has no Ribber Needle opposite it. Now put on the Clasp Ring again.

Now you can proceed to knit by turning the handle in the usual way. You can pull down slightly, but very steadily, and be sure you pull down vertically.

If you have followed these instructions carefully and everything has gone well, you have learned to work the Ribber. If you want to change from ribbed work to plain work you simply transfer the stitches from the Ribber Needles to the Cylinder Needles. First you put a Cylinder Needle into one of the empty Cylinder grooves and pull out the corresponding Ribber Needle until its stitch is behind the latch, then hook the Ribber Needle on to the Cylinder Needle, and, having seen that the Cylinder Needle has its latch open, slide the stitch on to it. When you have finished this operation the Ribber Dial will be quite clear of needles and all the stitches will be on the Cylinder Needles. Now you can proceed to knit as before, and, of course, the work now will be plain and not ribbed. You can either leave the Ribber where it is or you can take it out and put it into its place at the back of the machine.

The variety of ribbing possible is as follows:—

1	and 1	rib	=	1	plain	stitch	and	1	ribbed	stitch.
2	"	1	"	=	2	"	"	1	"	"
3	"	1	"	=	3	"	"	1	"	"
4	"	1	"	=	4	"	"	1	"	"
5	"	1	"	=	5	"	"	1	"	"
6	"	1	"	=	6	"	"	1	"	"

and so on, but the higher numbers, from 5 and 1 upwards are, generally speaking, more suitable for fine Cylinders of 108 grooves.

For a **1 and 1 rib**, all the Ribber Needles must be in the Dial, but only every **alternate** needle in the Cylinder, and the Dial must be adjusted so that the Ribber Needles are opposite the empty Cylinder grooves. This makes the most suitable welt for a gentleman's sock.

For a **2 and 1 rib**, all the Needles must be in both Cylinder and Dial, and the Dial must be adjusted so that the Ribber Needles are exactly central between the Cylinder Needles.

For a **3 and 1 rib**, every **fourth** needle is left out of the Cylinder, and every **alternate** needle out of the Dial; adjustment as for 1 and 1 rib.

For a **4 and 1 rib**, all needles are in the Cylinder, and every **alternate** needle in Dial; adjustment as for 2 and 1 rib.

For a **5 and 1 rib**, every **sixth** needle is **left out** of the Cylinder, and every **third** needle only is **left in** Dial; adjustment as for 1 and 1 rib.

Other ribs are formed in a similar manner to the above.

The Ribber Tension Screw and Pointer (page 23) make it possible to vary the length of stitch of the Ribber, and, of course, regular work requires that the length of stitch made by the Ribber should be as nearly as possible the same as the length of stitch made by the Cylinder Needles. It is better to try to get uniformity of stitch length by altering the Tension Screw of the Cylinder (L, page 6) and it is better to avoid altering Ribber tension if possible, because it may involve an alteration of the Timing Screw as well (see below). When the yarn is very fine or very coarse it may be necessary to alter the Ribber tension, and this is done as follows:—To make a long loose stitch unfasten the tension screw and move the pointer towards the centre of Dial, and when the pointer is in the desired position secure it in that position by making the Tension Screw tight.

The Timing Screw (page 20) should not be altered if it can be avoided. Before the machine is allowed to leave us the Timing Screw is adjusted to dead accuracy. When the machine is being worked the Ribber Needle must make its stitch neither too soon nor too late, but just exactly midway between the Cylinder Needle before it and the Cylinder Needle after it. If not properly timed the Ribber stitch is pretty certain to be dropped. Therefore, if you find that the Ribber Needles are dropping stitches, look for the trouble in the "timing." If the Ribber Needle seems to be taking its stitch too soon, turn the timing screw slightly to the right and if too late turn the screw slightly to the left.

General Hints.

Oiling the Machine.

The Machine should be kept well oiled, and oil may be applied with advantage wherever two metal parts rub together in working. The special parts to oil are:—

The Cylinder Grooves **with the needles in.**

The Dial and Dial Grooves **with the needles in.**

The Ledge inside the Shell.

The Crank Wheel Teeth.

The Crank Wheel Axle, or Stud.

The Worm on Crank Wheel Axle, which actuates Counter or Indicator.

Generally speaking, oil will do no harm except where it is likely to get on to the knitted work, but do not flood the Machine with oil. Oiling is best done frequently, and in small doses. The Machine

can then be kept neat and clean, and all fluff from the wool should be regularly cleaned off. A little trouble in this direction is well repaid by the sweeter running of the Machine. Only the best machine oil should be used.

Pay Attention to the Tension.

A careful record should be kept of the number of rows in the various sections of articles knitted, and of the tension at which they are knitted, as the latter affects very considerably the length of the knitting and the amount of wool consumed. The flange of the Tension Nut is numbered, and a record can be kept by noticing which number is to the front, and noticing also the height of the **top** of the nut.

If the Tension Nut is raised too high the wool will be carried round the top of the needles without forming stitches.

Care must always be taken that the two socks or stockings in a pair are **knitted at the same tension**, and that they contain exactly the same number of rounds in each part, otherwise they will not "pair" correctly when finished.

To suit some wools it may be necessary at times to alter the height of the Dial, and this is done by means of Ribber Arm Screw. To raise or lower the Dial, undo the small lock-nut, and turn screw to right to raise, and *vice versa*. When adjusted, tighten lock-nut again. The correct height for Dial is that it should just give comfortable room for the knitted work to pass down, allowing for occasional knots.

Regulating Height of Yarn Carrier.

An alteration in height of Dial may entail adjustment in height of Yarn Carrier. The correct height of Yarn Carrier is that the Ribber Needles, **with their latches closed**, shall just pass under without touching. If too high the Ribber Needles will drop their stitches; if too low they will catch and get damaged. It can be adjusted by undoing the screw in the slot at its lower end: tighten up again when set.

Selvedge for Men's Socks.

The quickest and best way of making this is by means of the **Selvedge Tappet**. (See illustrations on page 23).

Set Machine for 1 and 1 rib (see page 24), knit a few rounds, break wool, join on cotton and knit three or four rows for dividing, stopping Yarn Carrier at front of Machine. Break cotton, join on wool and knit **exactly one round**, and put Ribber Needles out of action by moving Switch Pin (see page 24) to the **OUT** position; then knit four rounds, holding the work **well down**, put Ribber

Needles in action again, and proceed to knit welt as usual. In moving Switch Pin, care must be taken to see that it goes the full distance, and rests in the **OUT or IN** groove, as required.

When putting Ribber Needles **in or out** of action, it may sometimes happen that a needle will be in such a position as to block the movement of the Switch Pin. In this case, work the Tappet Plate slightly forward so as to clear the needle; the Switch Pin can then be moved to the desired point.

For Selvedge for Flat Web see page 44.

Picking Up Slipped Stitches.

If a stitch slips off the needle from any cause it will generally, if the weights are on, run down through a number of rounds. The weights should be taken off immediately and the stitch picked up as follows:—

Take a spare Cylinder Needle and pass this down, hook end first, between the work and the Cylinder, with the hook pointing inwards towards the work. Pass the left hand up inside the Cylinder from underneath the Machine, take hold of the work and bring the dropped stitch within reach of the needle hook, get the stitch on to the hook, being careful not to split the wool, slide the needle through the stitch until the stitch is behind the latch, then turn the needle a quarter turn to the right, pull it slowly back until the latch stands out almost straight, but not quite, the stitch still being behind it. Then work the latch up behind the wool immediately above the stitch, this done proceed to draw the needle slowly back and the latch will take the wool inside the hook, allowing the old stitch to slide over and thus forming the new one. Having now a new stitch, inside the hook, slide the needle through the work again until the stitch is behind the latch, and repeat the whole operation until you get the stitch to the top, when it must be placed on its Cylinder Needle.

If the Ribber is in use when the stitch slips off the Cylinder Needle, the Ribber Needles must first be taken out, as directed in the next paragraph, and the complete ribbing attachment removed.

Picking Up Rib Stitches.

This is done on the same principle, except that, of course, it is done from the inside of the work instead of the outside. The whole of the Ribber Needles must be taken out of the Dial and left hanging to their stitches outside the Cylinder. The complete ribbing attachment can then be removed so as to allow free access to the work.

To Unravel Work While on the Machine.

This can only be done when the Ribber is not in use. Stop Yarn Carrier at front of Machine, push work up at the back so as to get the stitches inside the hooks of the needles; with Work Hook,

pull tightly outwards the cross thread of wool between two of the stitches and then pull this wool slightly upwards. This will free the last row of stitches and will cause the previous row to come over into the hooks. Get the stitches off about 20 needles at the back in this way, repeating the operation according to the number of rows it is desired to unravel, and raise these 20 needles out of action. Then knit round until Yarn Carrier is under the needles raised, and unravel the same number of rows off the remainder of the work in a similar way. With care, this can be done to any extent without dropping a stitch. Pull back the slack wool to the bobbin, raise 20 more needles leading up to the others so that the Yarn Carrier can be moved backwards in order to start knitting at the needle from which the wool hangs, and proceed to knit in the usual way.

If it be necessary to unravel when making the heel, pull the stitches into the hooks, draw the wool out tightly in a line with the hooks, then pull gently a little upwards and outwards, when the stitches will slide off. If in the first part of the heel, push a needle down as each row is unravelled; if in the second part pull a needle up each time.

To Knit Flat Web.

By this is meant knitted work which is flat instead of tubular when it comes from the Machine. It can be most conveniently done with **not less than one-third** of the needles removed from the Cylinder at the back of the Machine, knitting backwards and forwards with the **wool over Heel-spring**, just as in making heels. If specially desired, flat web can be knitted with all the needles in the Cylinder, but this involves putting a number of the needles in and out of action each course knitted. It is done as follows:—

Having formed the Selvedge, page 44, the **first** course must be knitted **backwards**. The Yarn Carrier must be under the first 24 needles upon which the Selvedge was put (for convenience sake we will refer to these as "batch A," and to the **last 24 upon which Selvedge was placed** as "batch B"), and the other needles must be pressed down into action, commencing with that upon which the **last** Selvedge stitch was placed, and working round the Machine backwards. When the Yarn Carrier is at the **left** of the Machine, press into action "batch A" and raise out of action "batch B"; knit round until last needle of "batch A" has knitted, then return and when Yarn Carrier is about half-way round raise **out** of action "batch A" and press **into** action "batch B." Knit round until last needle of "batch B" has knitted, then return, repeating the process each course knitted. By this means a good width of Flat Web is produced, of **any** length, and fairly large garments can be made with comparatively few joinings. Flat Web cannot be knitted with Ribber on Machine.

Releasing Upthrow Pointers when Blocked.

In knitting Flat Web it may sometimes happen that the Yarn Carrier will be taken too far, and the Upthrow Pointer get past one or two needles on the opposite side, which it is not intended to knit. Should this happen it will be found that in endeavouring to return the heel of a needle will block the passage of the Upthrow Pointer, and to remedy this that particular needle must be pressed down so as to give the Pointer a clear passage. A similar difficulty may arise by the Crank Wheel being accidentally turned back under other circumstances, especially when the Machine is set for 1 and 1 rib, and the remedy is the same except that in this case it will be necessary to **raise** one or two Cylinder Needles in front of the "forward" Upthrow Pointer so that it may regain its position **under the heels** of the needles.

Changing Cylinders.

Take off Ribbing Attachment and remove all needles out of Cylinder. Take out the two screws underneath which fasten the Cylinder to the Bedplate, and the Cylinder can then be lifted out. (In some machines it may be necessary to remove the Dial Adjuster before the Cylinder can be removed.) Put the new Cylinder in and start one screw, giving it two or three turns only; then start the other screw, **tightening up both gradually**. In changing Cylinders there is no need to disturb the Shell and Gear Ring, but lest they get moved out of place by accident, it is well, before starting, to turn the Crank Wheel so that the large knob is at the top and notice the position of the Yarn Carrier and Tension Cam. The Yarn Carrier is at the front of the Machine and the Tension Cam close behind it, the lug in which the Tension Cam Screw is fixed being between the two projections on upper side of Gear Ring, and the various parts must occupy these relative positions when the change is completed. If, in changing the cylinders, the upthrow pointers should fall out, it should be remembered that in replacing them the points should be pointing outwards and the longest side of the triangle should be uppermost.

Changing Dials.

Undo set-screw in the side of sleeve in which the centre stud for Dial is fixed; the stud will then slip out and the Dial and Tappet Plate may be taken off. Hold the Dial Stud, head downwards, in the left hand, place the new Dial on it with grooved face upwards, and drop the Tappet Plate over the stud on to the Dial. Then slide the Dial Stud into the Ribber Arm Sleeve, press home and fix firmly by means of the small set-screw at the side. The Tappet Plate should just move round freely, but must not have any play.

VARIETIES OF WORK.

The pages that follow give specific detailed instructions for many different kinds of knitting on the Golden Fleece Knitting Machine.

Gentlemen's Socks.

Plain and Ribbed Top.

Commence by forming Selvedge with the New Selvedge Tappet as explained on page 26, and knit 5-5 $\frac{3}{4}$ in. Ribbed Top (1 and 1 rib) for the welt; then place all the needles in the Cylinder where left out for rib, transfer the rib stitches on to these (see page 24), knit an 8in. leg, making 12 $\frac{1}{2}$ in. with ribbed top, and stop Yarn Carrier at front of Machine. Knit heel, foot (70 to 80 rows according to length required), and toe, and finish off, as explained in pages 14 and 15. Size of foot, 10in. to 11in.; medium, 10 $\frac{1}{2}$ in.

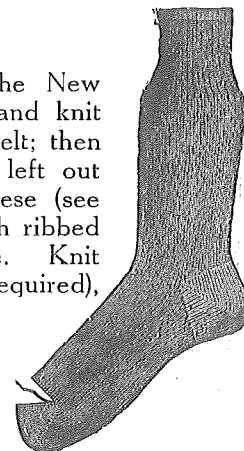

Gentlemen's Socks.

Ribbed.

Commence and knit welt, just as in foregoing paragraph, then put in additional Cylinder Needles to form 3 and 1 rib. Transfer the stitch from every alternate Ribber Needle to the new Cylinder Needle, taking Ribber Needle out, of course. Knit 8in. leg, stop Yarn Carrier at back of Machine, take 10 Ribber Needles out at front of Dial, transferring their stitches to Cylinder Needles, which must be put in the empty Cylinder grooves. (Some knitters take out the 10 Ribber Needles about 6 rows before the commencement of the heel, and this gives a large appearance to the heel). Bring Yarn Carrier round to front, take out Driving Pin to prevent Ribber Needles knitting, raise out of action the Cylinder Needles at back of half-cylinder marks, and knit heel as usual. At finish of heel, stop Yarn Carrier at front, press the Cylinder Needles into action again, insert Driving Pin, knit 6 to 7 round, then put in one Rib Needle at each side. Knit length of foot required, stop Yarn Carrier in front, knit toe exactly as heel, taking out of the Rib Needle on each side. Stop carrier at front and transfer every other plain stitch to Rib Needle to make one and one rib, knit a few rounds and join on cotton.

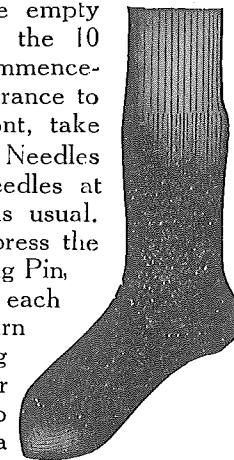

Ladies' Ribbed Hose.

4 and 1 rib. With Scalloped or Vandyck Top.

Put on Selvedge in usual manner with all Cylinder Needles in; knit one round (or, if you wish to make the scalloped top more pronounced, make two rounds, in which event there will be three cross-threads to catch up) put on Ribber without needles in the Dial, and regulate Dial for 4 and 1 rib; then proceed to put in every alternate Ribber Needle, at the same time catching up into its hooks **both** the cross-threads of wool (it will be noticed there are two between the Cylinder Needles. Tighten tension nut two or three points, knit 6 rows, slacken tension again, and knit length of leg required, say, 12 inches.

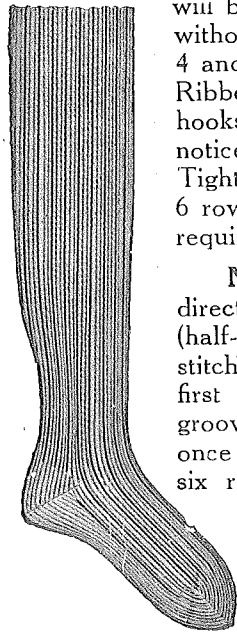

Narrowing Ankle.—Lift out two needles directly in front of Machine on the left of Rib Needle (half-way between the half-cylinder marks), place the stitch of the second needle on the third, place the first needle in the second groove, leaving an empty groove in front of Dial needle. Knit six rows, narrow once on each side of first narrowing, knit a further six rows, narrow again once on each side of last narrowing, and repeat this until the narrowings have gone all round the Machine. The result is then a 3 and 1 rib, and the Dial should be re-adjusted so that the Ribber Needles will now be central with the Cylinder Needles. Knit 45

rounds for ankle, and make heel, foot, and toe as in gentleman's sock, but shorter. Size of foot, 9 to 10 inches; medium, 9½ inches.

Ladies' Ribbed Hose.

With Hem Top.

A Hem Top is made as follows:—Take Ribber off Machine, have stitches on all Cylinder Needles and proceed to knit straight off, after the dividing cotton, there being no need to form a selvedge. Knit from 10 to 20 rounds according to depth of hem required; then pull the work up inside the Cylinder and place the first row of stitches on the needles (so that there will be two stitches on each needle) being careful not to twist the work; knit one round, put Ribber on and adjust for 4 and 1 rib; catch a stitch up on to each Ribber Needle from the **back** of the adjoining Cylinder Needle and proceed to knit stocking as usual.

Ladies' Ribbed Hose.

With 3 and 1 Welt.

Start without Ribber, all Cylinder Needles in, form selvedge in usual way, knit one round only, put on Ribber, adjust for 3 and 1 rib by putting in every alternate Ribber Needle, transferring a stitch on to same from the Cylinder Needle in front of it, which will then, of course, be taken out. Knit 3 or 4 inches, as desired, for welt; adjust Dial for 4 and 1 rib by putting in the other Cylinder Needles, catching a stitch on to each from the **back** of the **adjoining Cylinder Needle**. Proceed to knit stocking as usual.

If **Scalloped or Vandyck Top** be preferred, start with every fourth needle out of Cylinder and knit one round before putting Ribber on. Then put Ribber Needles in opposite the empty Cylinder grooves, catching up the **two** cross threads of wool to form first stitch, as explained on page 31, paragraph 1.

Ladies' Plain Hose, Fashioned.

On 80-Cylinder Machine.

A lady's plain stocking can be knitted and fashioned as follows:—

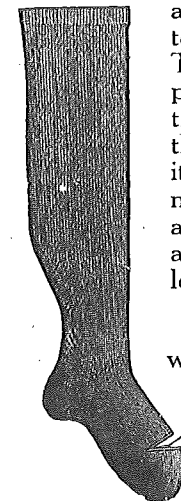

Commence with Hem Top, or Ordinary Selvedge, as preferred, knit 4 inches with tight tension, slacken tension, and knit usual length of leg prior to narrowing. Then begin to knit flat web with all needles in (see page 28) dividing at front of Machine, half-way between the half-cylinder marks. Narrow by taking out the third needle on **each** side of the division, transfer its stitch on to the fourth needle, and close up by moving the first and second needles into the second and third grooves. Knit 8 rows, narrow on each side again, and so on, narrowing 6 times in all, which will leave 60 needles in.

Raise out of action 15 needles at each end which will be used later for the heel. Knit the top of the foot backwards and forwards on the other 30 needles, say, 50 to 60 rows, according to length of foot required. Then commence narrowing exactly as in the leg, but knitting only two rows between each narrowing, and continue until only 6 or 8 needles left in the work. Now press down into action all the needles remaining in the Cylinder, and take off the Clasp Ring. Bring together all the 30 needles for the heel by moving one lot to the other side, and knit the heel on these in the usual

way. After finishing the heel, knit the lower part of the foot exactly like the upper part.

When the Stocking comes from the Machine, it will require joining up at the toe, the sides of the feet, and the back of the leg from the commencement of the narrowings to the beginning of the heel.

Men's Hose.

These are knitted same as Ladies' Hose except that the wool used is of stouter yarn, and the tension consequently a few points looser. They are usually made with the 3 and 1 welt top, the length of leg and foot being altered as required. Length of leg is generally about 22 inches over all.

A Youths' Stocking.

This can be fashioned by knitting Flat Web where the narrowings are to begin. Knit Welt and Leg as in men's plain sock (see page 30) and when ready to narrow, commence knitting flat web on all the needles, as explained on page 28. Let the division in the work come at the back of the Machine, and exactly half-way between the half-cylinder marks. Narrow on each side every ten rounds, by taking out the third needle from the division and placing its stitch on the fourth needle. Put the second needle in the third groove, and the first in the second, on each side. After sufficient narrowings have been made, knit the required length for ankle and make the heef half on each side, as in Child's stocking (see next paragraph). Knit the toe at the front of the Machine as

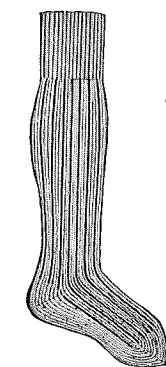

usual, and then join up the lower half of leg and the under side of foot, along with the toe, after the stocking leaves the Machine. The joining must be carefully done, and pressed so that no ridge is felt.

Child's Sock or Stocking.

Made on the Flat Web plan.

Have the necessary number of needles in Cylinder according to width of stocking (or sock) desired, form selvedge on these in the usual way, and make the length of leg required, by knitting backwards and forwards, just as in making heel and with the wool in heel spring. The ankle may be shaped by tightening the tension slightly. Finish the leg by knitting to the left.

The heel is knitted half at each side of the work. Raise out of action all needles except 12 at the left. Knit to the right, raise out of action the last needle knitted, knit to the left and right again (a double course), raise another needle, and so on, raising one needle each double course knitted until you have only about three needles left, then commence pressing these needles into action again, one each double course, placing the yarn behind the needle, just as in doing the second part of an ordinary heel, and then proceed until you have 11 needles in action (or one less than you started the heel with), then press all the remainder into action, knit right across and do the other half of heel at the opposite side in a similar way.



The toe is best knitted in the centre of the work at the front of the Machine, just in the ordinary way, but, of course, with a suitable number of needles, say, 24.

Smaller sizes, even doll's stockings, can be done by starting with fewer needles, and when first trying the experiment it is best to take at least 30 needles out of the Machine.

A mock rib top can be made for the welt by leaving out every alternate Cylinder Needle, and in that case it will be necessary to start with an **odd** number of needles. Knit welt with a rather tighter tension.

Child's Sock.

With Ornamental Body Part.

A very nice effect is produced by making a plain welt and then knitting the body, or leg part with a fancy "pyramid" stitch as follows, working on the flat web plan as on page 28:—

Raise out of action the first needle on the left hand side of Machine, and every fourth from the first needle you raised. Hold the work well down, and knit three rows; press into action all needles that are raised and knit two rows; raise the third needle from the end on the left hand side of Machine, and every fourth from the third needle raised; knit three rows, then press needles into action, and knit two rounds. Repeat this several times to give required length of leg; knit ankle plain, and finish as on pages 14 and 15.



Gentlemen's Cycle Stockings.

With Striped Top.

Commence with small hem top as in Ladies' Stocking (see page 32) and after knitting a few further rounds, run in stripe of 3 or 4 rounds of another colour. Join on original colour again, making striped top of 4 to 5 inches with 1 inch of main colour at commencement and finish, say, 6 to 7 inches altogether for the turnover top. Then take the work out of the Machine, turn it inside out, pick the stitches on to the needles again, and knit the leg in the usual way, commencing with 4 and 1 rib. The length of leg over all may be 24 to 27 inches, or 18 to 20 inches when the top is folded over.

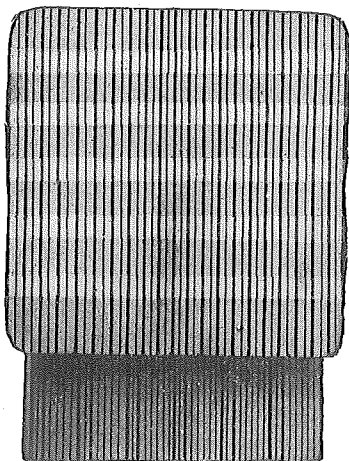

The pattern is proved by varying the width of the stripes, and may be elaborated by further ornamentation by hand after the stocking leaves the Machine.

Gentlemen's Cycle Stockings.

With Diamond Top.

This makes a very effective Cycle Top, though it requires a little patience to work out the first time. It is done on the principle of small heels all round the Machine, and the following particulars are for a 6-diamond top made on the 80-Cylinder Machine. Commence with small hem top as in paragraph 1 on this page, and run in stripe in the same way. Knit 3 rounds of original colour and 3 rounds of another colour (same as stripe or different, according to wearer's preference).

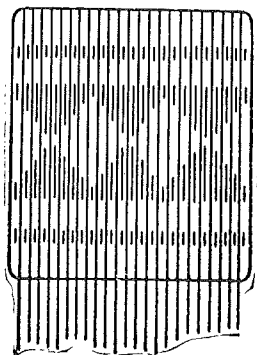

(a) Raise out of action all needles but 12, put wool over Heel-spring, knit backwards and forwards as in making heel, raising one needle each course knitted. See that both end needles knit each time, and particularly the last stitch when only one needle is left up. When this last needle is raised, press down into action the next 12 needles, and repeat the process all round the Cylinder. In passing from one lot of 12 to another let the wool remain outside the needles, and it will knit in later on.

(b) When the last batch of 12 has been knitted break the wool join on the colour you wish to use for the actual diamonds, press down the **sixth** needle from the last one knitted, knit forward (making sure that the needle knits), press down the next needle on the same side as the wool, place the **wool behind the needle**, knit backwards, press down another needle, and so on, just as in second half of heel until you have twelve needles in action again, the last course being knitted backwards. Then begin raising these needles again, one each course knitted as in section (a). When the last needle is knitted and raised bring the Yarn Carrier back a little so as to be able to knit **forward** the first course in the next diamond, press down the 11th needle from the last one knitted, and repeat the same process all round the Cylinder.

(c) Then change the wool back to the preceding colour, press down into action the **fifth and sixth** needles from the last one knitted. Knit forward and backwards until 12 needles in action, last course being knitted forwards. Raise the 12 needles out of action, move Yarn Carrier backwards a little press down into action the **sixth and seventh** needles from the last one knitted, and repeat all round the Cylinder as before. In the last half-diamond, before knitting forwards on the last 12 needles, press down into action **all** the needles as far as possible, knit half-way round, press down remainder, knit several rounds, run in original colour and stripe, finishing with original colour to match the commencement of the diamond top. Take the work out of Machine, reverse, and put stitches on needles again, proceeding exactly as on previous page.

Gentlemen's Cycle Stockings.

With Large Hem Top.

This method obviates the necessity for taking the work off the needles and reversing. No selvedge need be formed, but instead of the usual small hem top knit about 4 inches of the principal colour, then make fancy portion (diamond, striped, or other ornamental pattern), finish top with a further 4 inches of principal colour, then pull up the work inside the Cylinder and place the first row of stitches on the needles, forming a large hem top. When the stocking comes from the Machine, fold the hem over in the usual manner. The proper way to fold a hem top is so that the joining shall come at the middle of the inside, and the full pattern be displayed.

Gentlemen's Cycle Stockings.

With 1 and 1 Striped Rib Top.

The appearance of a 1 and 1 rib being practically the same on both sides, a Striped Cycle Top formed with this rib need not be taken off the needles to reverse, but can be knitted straight on and folded over afterwards in the usual way. A 1 and 1 rib Cycle Top should be knitted with slack tension, especially on a 80-Cylinder, otherwise it may come out too small.

Children's Combinations.

Knitted in four pieces in Vest Wool, or 4 or 5-ply Fingering, on 80-Cylinder Machine.

Set up, making selvedge with Selvedge Tappet as directed on page 26 with 1 and 1 rib. Knit 30 rows with tight tension; then transfer rib stitches on to plain needles, stopping with Yarn Carrier in front of Machine. Take off Ribber; lift all the needles at back half of the Machine out of their grooves and let them drop inside the Cylinder **with the stitches remaining on them.** Knit forwards, taking the Yarn Carrier to the back of Machine where the needles are out of Cylinder; loosen tension; put wool into heel spring; knit backwards and forwards four rows and increase one needle on the right side by moving two end needles a groove forward, putting a needle into the empty groove and catching with this extra needle a stitch from the **back** of the next needle to it. Knit another four rows in the same way and increase one needle again on the right, repeating this operation until you have 46 needles in the Machine. Then increase one needle every **sixth** row until you have 54 needles in, after which knit 36 rows. Cast off eight stitches; knit 130 rows; cast off 27 stitches; knit 16 rows and run work off Machine, being careful, of course, not to let any stitches slip back. This forms half **back** of combination.

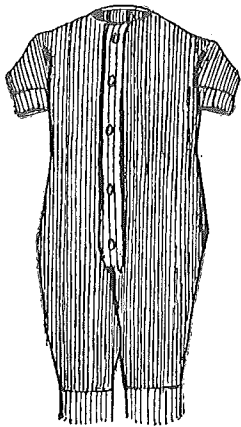

Now insert in front of the Machine the needles which were left hanging in the work with the stitches on them and, still using the take-up spring, proceed as before, but increase on the **left** side until you have 46 needles in. Knit 200 rows; cast off 27 stitches; knit 20 rows, and run work off Machine. This forms half **front** of combination. The two parts are then joined together at the shoulder with the knitting stitch just as used in joining up the toe of a stocking, and if this is neatly done the joining will not be perceptible. The two parts when joined together form one-half of the complete garment.

Make the two pieces for the other half in a similar manner, but reverse the sides for increasing and decreasing in each case. When these are completed, join neatly together and finish the neck and sleeves with the crochet stitch.

Sleeves can be knitted for the foregoing by commencing as for gentlemen's socks—1 and 1 rib, knit 20 rounds tight tension; transfer

rib stitches to plain; loosen tension; knit 25 rounds; break wool and tie on cotton; knit 3 rounds and change needles back to 1 and 1 rib for next sleeve. Press the stitches of sleeves before joining on to combination.

If preferred the front of the garment can be left open about 5 inches at the top.

Casting off stitches is done as follows:—Take out the needle which knitted the last stitch, catch the wool inside the hook and draw it through the stitch, this makes another stitch which must be placed on the next needle.

Muffler or Scarf.

Knit about 36 inches plain with all needles in Cylinder; then throw every alternate stitch off its needle and pull the work so that these stitches run back to the commencement. Finish off with fringe or tassel at each end.

Motor Scarf.

A very neat two colour Motor Scarf can be made by knitting two separate lengths as directed in previous paragraph, in two different colours. Lay the one flat on the other, join up each side with crochet or chain stitch, and finish off the ends with fringe.

Child's Toque or "Monkey Cap."

No selvedge is necessary. Proceed to knit straight on after dividing cotton, but with **very loose** tension. Knit 60 rounds and pull up the work to form hem top; knit further 20 rounds, still with loose tension, then tighten tension 4 or 5 points, run in stripe of 3 or 4 rounds, tighten tension slightly, knit 10 rounds original colour, tighten tension a further 3 points, run in another stripe, tighten tension again and knit length required, say, a further 9 to 12 inches. A third strip can be run in if desired.

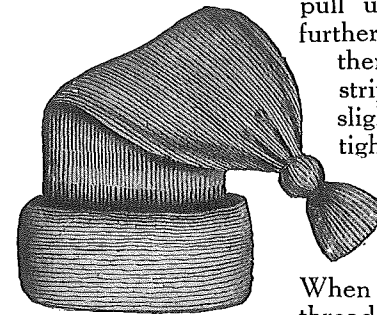

When finished, draw the end up, passing a thread of wool through the stitches, and finish off with a bob and tassel.

If desired, the roll (or head part) can be made to fold over twice (3 thicknesses) instead of the hem. In this case, a selvedge must be formed, and 100 to 120 rounds knitted before running in first stripe.

Cord.

A very neat cord can be knitted by having only 2, 3, 4, or 5 needles in the Cylinder at the front of the Machine. Commence the work by looping the wool round each needle, and to and from the weight hook between each stitch so that the work will be properly pulled down. Pass the wool over heel-spring, and knit round the Machine in the usual way. The effect is enhanced by using variegated wools.

Lady's Ribbed Vest.

In 3 or 4-ply Vest Wool.

Commence with Scalloped Top, as on page 31, knit 56 inches with **very loose** tension for the body part (This is double length, having to be folded afterwards). Run in dividing cotton, and knit in a similar manner two pieces, each 5 inches long, for sleeves, separating with cotton as usual.

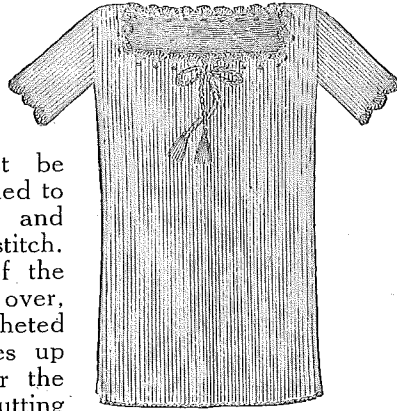

To Finish.—Body part must be pressed, two or three rows unravelled to get an even row of stitches, and finished off with loose crochet stitch. Then cut up evenly along one of the rib stitches, open out flat, fold over, bringing the Scalloped and Crocheted edges together, and join the sides up neatly, leaving 8 inches space for the sleeves. The neck is made by cutting out a rectangular piece, leaving the front one inch lower than the back. Finish neck with crochet or ornamental stitch and draw-cord.

Boy's Jersey.

2 and 1 Rib.

Set the Machine for 2 and 1 rib, knit 20 rounds with tight tension, loosen tension and knit 350 rounds; tighten tension again and knit 23 rounds. This forms the body part of Jersey. Run in dividing cotton, change to 1 and 1 rib, and form selvedge with Selvedge Tappet; knit 4 inches, put remaining Cylinder Needles in to form 2 and 1 rib, catching up a stitch on to each from the back of needle on the left, loosen tension and knit sleeve of length required. Knit the two sleeves, dividing with cotton, and knit 4 inches in 2 and 1 rib for collar.

To Finish.—Press body part, collar and sleeves. Unravel three rounds from body, and work a loose chain stitch round. Cut up and fold over and join up sides same as Lady's Vest, leaving 7 inches for sleeves. Secure stitches of sleeves and collar by running a thread of wool through. Cut across top of Jersey width required for neck, turn collar inside out, sew on firmly, and turn over to form roll.

Knee Cap.

Commence with Scalloped Top, 4 and 1 rib, as on page 31, knit 50 rounds, take off Ribber, transferring the rib stitches to Cylinder Needles, and raise 9 needles out of action at the back of Machine. Knit on the remaining needles to form the knee part, as if making the first half of a very large heel, raising one needle out of action each course knitted. During the first 12 rounds it will be found necessary to raise additional needles each time, beyond those already up, so as to allow the V cam to pass sufficiently forward to knit the last needle in action, and on the return course these additional needles must, of course, be pressed down again. After the first 12 rounds or thereabouts, a sufficient number of needles will be out of action to render this unnecessary. Continue decreasing until only 15 needles are left in action, letting the last course be knitted to the right, but stopping Yarn Carrier at front of Machine. Press all needles into action, put on Ribber, change to 3 and 1 rib, commencing with the 9 needles first raised out of action, and working round the Machine in the usual direction. Knit 50 rounds and finish off. Secure the stitches by passing a thread of wool through, or by any other desired means, when the work comes from the machine.

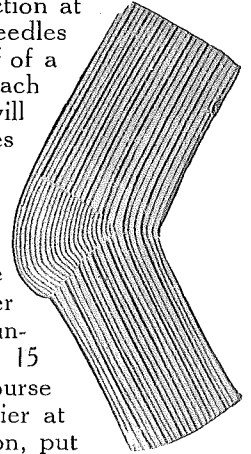

Ribbed Mittens.

Make $4\frac{1}{2}$ inch ribbed cuff just like welt of Gent's Sock, change to 3 and 1 rib, knit one inch, take out at front of Machine 6 Ribber Needles, inserting corresponding Cylinder Needles to which the stitches must be transferred. This will give 21 Cylinder Needles together, upon which the thumb will be knitted. Bring Yarn Carrier to the front so that the V cam is under these 21 needles, put in remaining Cylinder Needles, take off Ribber, transferring the stitches to the empty Cylinder Needles, and raise out of action all but the 21 needles for the thumb. Knit backwards and forwards (flat web) 40

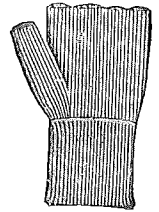

rows, holding work well down, break the wool, and then lift from **each** selvedge edge of the thumb stitches on to 11 needles, being careful that there are no holes at junction of hand and thumb. Bring Yarn Carrier round to the left, join on wool, and knit forwards to bring V cam under the 21 needles again, holding the thumb part well down. Put Ribber on, change back to 3 and 1 rib, and knit 40 rounds to complete. Finish off the ends of thumb and hand with chain or other suitable stitch, and press.

Plain Mittens.

Plain Mittens are made either with ribbed cuff or large hem for double cuff. In either case, about one inch plain should be knitted after the cuff before commencing the thumb. In this case the trouble of putting the Ribber off and on again in doing the thumb is saved. The end may be left open, or closed as in toe of sock.

Stripes may be run in either plain or ribbed mittens if desired.

Girl's Victorine, or Cape.

Start flat web on, say, 50 needles. Knit about 10 inches, raise one needle on the right, knit one course, raise another needle on same side, continue knitting to and fro, raising one needle each course and always on the right, until only four needles are left in action. Press all needles down again, knit one or two complete rows, and then decrease again one needle on the right each course. Repeat this until five of these taper sections have been knitted, and then knit 10 inches full width again. The cape may be wadded and lined, and fringed at the ends. The effect is considerably enhanced by using "Eis," "Ostrich," or other fancy wools. If a larger size be required add one or two more of the taper sections, and knit the plain part also a little longer.

Toilet Mat.

Neat Toilet Mats in white cotton may be made by knitting in taper sections as explained in previous paragraph. Six sections will make the complete circle, and the outer edge should be fringed or finished with some ornamental stitch.

Table Mats may also be made in wool, varying the colour for the different sections. If two needles be raised each time there will be twelve sections to the circle instead of six.

Babies' Overalls.

In White, or other suitable Wool.

A Baby's Overall, similar to the lower half of Children's Combinations, but with feet, is made as follows:—Commence with ordinary selvedge, knitting flat web, on 40 needles, slack tension. Knit 8 rows; then widen one stitch, knit 4 rows, widen again, and continue widening every 4 rows until 55 needles are in use. Then knit 8 rows, after which begin to narrow two stitches every 4 rows, and continue until 16 narrowings have been made. Run in dividing cotton, and knit another piece exactly like the above, following on with two other similar pieces, but with the widenings and narrowings on the opposite sides. Join up the four parts neatly to form the upper portion.

For the feet knit 40 rows on 54 needles, no selvedge being necessary; run in dividing cotton, and knit another 40 rows for the other foot. These pieces are doubled over to form the feet, and joined up to the ends of the legs with the usual joining stitch, as used in finishing the toe of a stocking. For the front part of feet, the knitted web is turned in to the shape required and joined up or worked over in any suitable way.

Finish off the waist with crochet stitch, and run in draw-cord both at the waist and ankles.

Baby's Jacket.

In Blue, White or other Colours.

A Child's Jacket is made on a similar plan to the Boy's Jersey, but is also cut down the front, the edges being worked over with a suitable ornamental stitch. The neck, instead of a collar, should have a fancy pattern crocheted round, and a draw-cord should be run through at the waist. Some of the fancy stitches are very suitable for articles of this kind.

If the sleeves are required narrow, they must be knitted flat web, and joined up as usual.

Fancy Stitches.

These fancy stitches make very attractive patterns, but in most cases the effect cannot be adequately realised in woodcuts, and we therefore recommend our customers to try a length of each in order to see the actual effect produced. They are well worth the trouble of working out, and they lend themselves to a variety of purposes, e.g., scarves, table mats, antimacassars, children's bonnets and caps, trimmings, &c. They can be knitted either "flat web" or all round the machine, and most of the patterns can be varied by altering the number of needles and the number of rows knitted between each alteration. Commence with ordinary selvedge in each case, knit a few rows plain and have tension **loose**. When knitting backwards and forwards always thread wool over heel-spring.

Chevron, or Herring-Bone Pattern.—Have needles in every groove, knit once across or round, put the stitch from each alternate needle on to the next needle to the right, knit one row, forming loops across the empty needles, change the loops one needle to the right; knit one row, change loops again, and repeat, say, twelve times; then change the loops to the left for the same number of times: afterwards again to the right until sufficient length knitted.

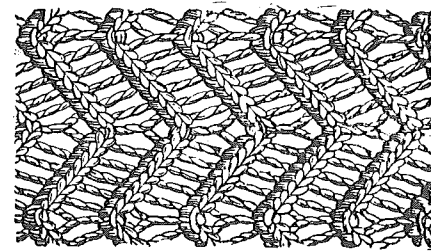

Net, or Filet Pattern.—Needles in every groove; raise out of action all but five; knit to-and-fro five rows, last row backwards; press into action the next five needles, knit across the ten, raise the first five out of action, knit five rows across the remaining five; press down the next five, knit across the ten, raise the previous five, and so on. Start the second row two stitches earlier or later to vary the position of the holes.

Bar and Diamond Pattern.—Change every alternate stitch to the left, knit across or round, forming loops, and back forming stitches on the empty needles; change the stitches formed with the loops to the right. Knit twice across, or round, as before, change to the left, and so on.

Honey-Comb Pattern.—Every alternate needle out of Cylinder. Raise every 2nd needle, knit 2 rows, press down the one lot of needles and raise the others, knit 2 rows, and so on.

Lace-Work Pattern.—Raise every 3rd needle, knit 3 rows, press all needles down, knit one row, raise same needles again, and repeat. This pattern is more effective with every alternate needle out of the Cylinder.

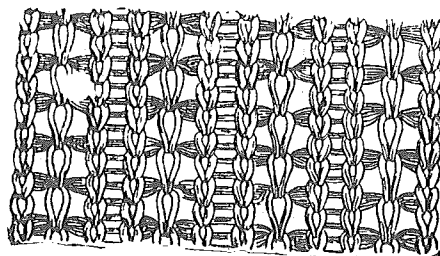

Lattice Pattern.—Transfer stitch from every alternate needle to the one on the left, knit one row forming loops, move the loops one needle to the right; knit one row, move loops to left, and so on.

Another form of Lattice Pattern is produced by moving the loops alternately to right and left in the same row, and reversing in the next row. Start on the same needle each time.

Pyramid Pattern.—All needles in Cylinder, raise every 6th needle, knit 4 rows; press all needles down, knit 2 rows; raise the middle needle of each group in the first section, knit 4 rows; press all down, knit 2 rows; and so on.

Special Ribbed Pattern.—This requires very loose tension. Change every 3rd stitch one needle to the left, knit one row forming loops, carry each loop over the needle both to its right and left so that it will then be in front of 3 needles; knit one row forming loops on the same needles again, carry them to right and left as before, and continue. This forms an exceedingly neat pattern.

Ribbon-Work Pattern.—Take off clasp ring, knit several rows take out alternate lots of 3 needles, letting them hang on their stitches inside the Cylinder, and thus leaving 3 in and 3 out. Knit 3 rows, put all needles in, knit 3 more rows, and throw out the other groups of needles in the same way as the first. Continue thus, throwing out first one set of needles, and then the other.

To Form Selvedge for Flat Web.

Raise out of action all needles not engaged in V cam. Holding down the work, knit forwards until V cam passes under the needles raised out of action, thus releasing those which were engaged in Cam, and these must now be raised also. Break the cotton, leaving a short length hanging, say, 10 or 12 inches, and pass this down inside the Cylinder. It will now be noticed that the Crank Wheel may be turned freely, without working the needles, which are therefore "out of action."

Thread Machine with wool, leaving about a yard hanging on the inside, over the Cylinder. Make a neat slip knot at the end of the wool, and drop this over one of the needles at the right hand side of the Cylinder, to form the first stitch. Then, taking the wool in the right hand, pass it **across the back** of the next needle away from you, round it, and in again at the side nearest to you; then along the back of the next needle farther away from you and round it in the same manner.

In doing this, **hold each loop down** (with forefinger of left hand) **close to top of Cylinder**, whilst making the next. The Yarn Carrier may be moved freely out of your way in either direction, as the needles are out of action, but care must be taken to keep the wool outside the needles.

The illustration below shows the direction and the method in which the wool should be twisted round the needles to form the loops, commencing from the right hand side, working towards back of Machine, and continuing in this same direction all round the Cylinder until a loop is on every needle.

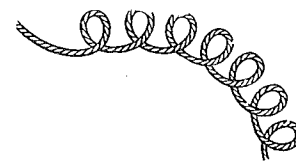

This Selvedge must be of medium tension—neither very tight nor very slack. Having placed loops on all the needles, have Yarn Carrier at front of Machine (the side nearest to you); press down into action about two-thirds of the needles, commencing with that on which the first loop was placed; **see that all latches are down**; take up any slackness in the wool; **pull work well down**; turn handle slowly forward; see that the wool feeds into the hook of the **first** needle; and knit half-way round. **(Whenever you stop knitting do not let Yarn Carrier move backwards.)** Having moved the V cam forward, the remaining needles can now be pressed down into action. Again, see that **all needle latches are down**, and proceed to knit slowly, holding work well down. There being a double stitch (the cotton and wool) on each needle, the Crank Wheel may work a little stiffly in knitting the first round. Practise the forming of Selvedge until thoroughly mastered, and do not attempt to knit too quickly at first. In this, as in other things, speed will come by practice

STANDARD SOCK (made on the 80-needle Cylinder).

Arrange needles for 1 and 1 rib as explained on page 24. Commence with four rows of selvedge stitches (see page 26). Knit 55 rows (about 5 inches) of ribbed top—1 and 1 rib.

Commence at the left half mark to take out every alternate Ribber needle and transfer the stitches to additional Cylinder needles. The needles will now be arranged for the 3 and 1 rib and will appear as follows:—

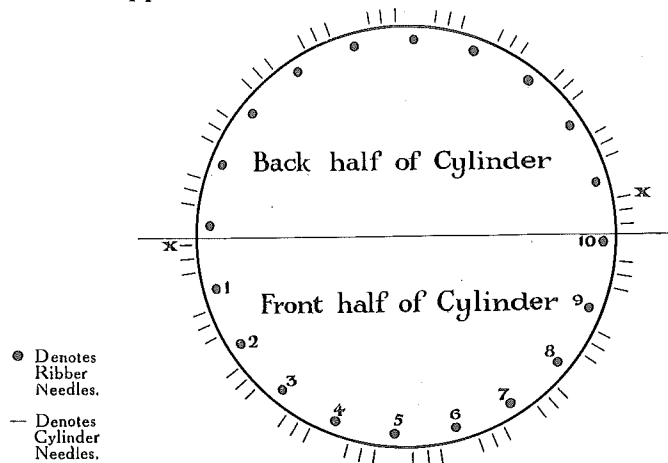

Note: When turning heel and toe—

1. Take out Driving Pin, and
2. Raise all Cylinder Needles in back half of Cylinder between and including those marked thus x

Knit 75 rows (about 8 inches) of 3 and 1 rib for the leg. Stop Yarn Carrier at the back of Machine. Take out the ten Ribber needles in front of Machine (numbered 1 to 10 in above diagram), transferring the stitches to additional Cylinder needles. Knit 10 rows.

Bring Yarn Carrier round to front of Machine, take out Driving Pin (this is the loose pin which fits in the Ribber Arm), so as to prevent Ribber needles working. Raise out of action all Cylinder needles between and including those marked thus x in above diagram, and proceed to knit heel in the usual way. (N.B.—Work until 17 needles remain down in front of Machine.) At the finish of the heel, press into action the Cylinder needles at the back half of the Machine and insert Driving Pin.

Knit length of foot required. The correct measurements for the various sizes are given on page 46. The number of rows should therefore be regulated so as to give these final measurements *after* the socks have been taken off the board pressed.

Stop Yarn Carrier in front, and knit toe exactly in the same way as the heel, being careful to take out the Driving Pin before proceeding. Replace Driving Pin, knit three extra rounds for unravelling when closing the toe, then join on dividing wool. Insert all ribber needles, transferring the stitches from Cylinder needles in every case.

The needles are now arranged for 1 and 1 rib again. Knit a few rounds with waste or dividing wool before commencing the next sock.

When you have completed your first pair of Socks send them to our Hosiery Works at 48a, Belgrave Gate, Leicester, for examination. We will keep one of them and return the other to you with our comments.

Sizes and Measurements for Ribbed Socks or Half Hose.

For those not fully conversant with the correct measurements for Gent's Half-Hose or Socks, this table will act as a guide. The measurement of leg and welt is governed by the size of the foot, and below we give the necessary particulars:—

Foot.	Welt.	Centre of Heel to Top of Welt.
9½ inches.	5 inches.	13½ inches.
10 "	5¼ "	14 "
10½ "	5½ "	14½ "
11 "	5¾ "	15 "

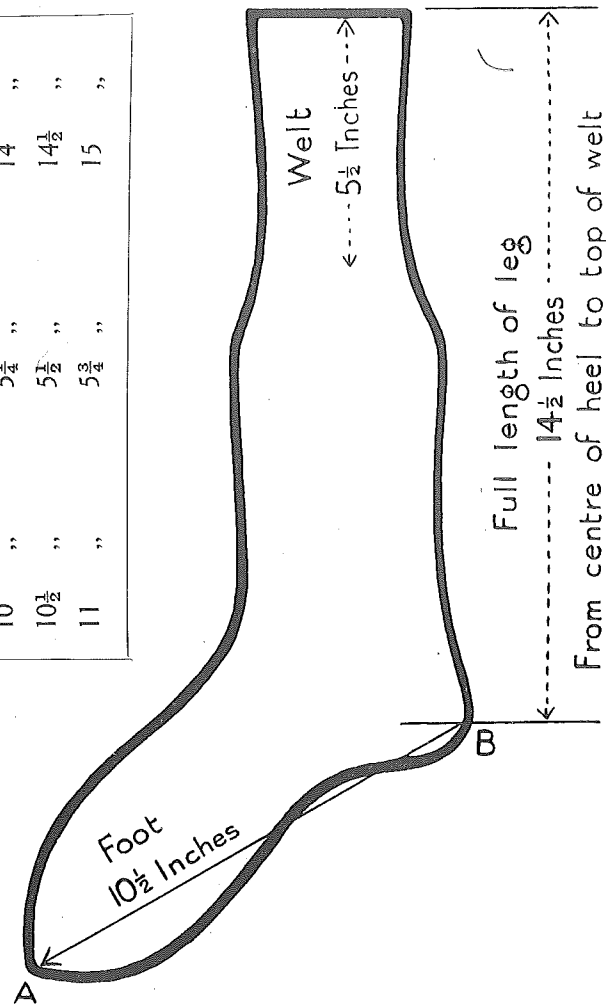

For the purpose of illustration we show a size 10½ in. sock, and this clearly indicates how the measurements are defined and the points from which to measure to arrive at the length of foot, leg and welt.

*Note:—*Measurement for foot to be taken from point A to point B.

Youths' or Boys' Fancy Turnover top Stockings.

Form Selvedge with Selvedge Tappet (see page 26) 1 & 1 rib, and after knitting a few rounds, run in stripe of 3 or 4 rounds of another colour. Join on original colour again, and so on, to form fancy top as desired. Length of welt (which forms turnover top) should not be more than $3\frac{1}{2}$ to 4 inches. Change to 3 and 1 rib for leg as in Gentleman's Socks and knit straight leg for the length required. Take 7 Ribber Needles out for heel, knit 10 rows with tension slightly tightened and make heel on the 31 Cylinder Needles at the front of Machine, if work is being done on 60 Needle Cylinder. If however the 80 Needle Cylinder is being used it will be necessary to take 10 Ribber Needles out for heel and make heel on the 43 Cylinder Needles at the front of Machine, taking out Driving Pin as usual. To finish second half of heel follow closely details given in pages 12 and 13. The toe is made in the same way as heel. In joining up the toe, it will be found necessary to join **two** stitches at the one side to **one** stitch at the other, about every third stitch.

Sizes are as follows:—

Size 3	7 inch foot, full leg length	$16\frac{1}{2}$ inches, and when turned down	13 inches
" 4	$7\frac{1}{2}$	18	$14\frac{1}{2}$..
" 5	8	19	15 ..
" 6	$8\frac{1}{2}$	$19\frac{1}{2}$	$15\frac{1}{2}$..
" 7	9	20	16 ..
" 8	$9\frac{1}{2}$	$20\frac{1}{2}$	$16\frac{1}{2}$..

Note:—Selvedge must be formed slightly tighter than leg, so that when turned over, the top lies evenly on the leg and does not become bell shaped.

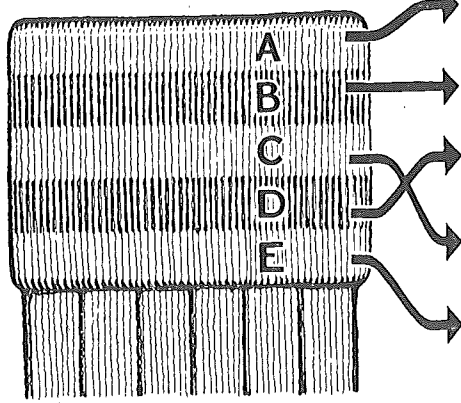

	Size 3	Size 4	Size 5	Size 6	Size 7	Size 8
Measurement (A) from top of Turnover to top edge of stripe	Ins. $\frac{3}{4}$	Ins. $\frac{3}{4}$	Ins. 1	Ins. 1	Ins. 1	Ins. $\frac{3}{4}$
Two Fancy Stripes (B and D) each measure in depth	$\frac{1}{2}$	$\frac{1}{2}$	$\frac{1}{2}$	$\frac{1}{2}$	$\frac{1}{2}$	$\frac{3}{4}$
Measurement (C) between Stripes in centre of turnover	1	1	1	1	1	1
Measurement (E) from bottom edge of bottom stripe to bottom of turnover	$\frac{3}{4}$	$\frac{3}{4}$	1	1	1	$\frac{3}{4}$
TOTAL DEPTH OF TURNOVER	$3\frac{1}{2}$	$3\frac{1}{2}$	4	4	4	4

NOTE CAREFULLY.—It is very important that top and bottom borders must be equal in depth.