

LINKING MACHINE

MOD. DL 1000

INSTRUCTION BOOK

Congratulations on your purchase of this Linking Machine, DL1000.

This machine is a top quality product which will enable you to make up knitted garments with accuracy and save you a lot of time.

For best results from your machine, may we suggest that you read the following instructions carefully.

CONTENTS

NAMES OF EACH PART	2
INSTALLATION	3
FUNCTIONS OF EACH PART	4
Release Dial	4
Hand Wheel	5
Hook Needle	5
Point Needle and Scales	5
Tension Dial	6
Lock Knob	6
START LINKING	7
Threading the machine	7
Hang open stitches	8
Hang side edge	9
Start stitching	9
Finish stitching	10
Cut the yarn end using Yarn Cutter	11
Keep the yarn without cutting	11
When linking long fabric	12
Continue to stitch another fabric without cutting yarn	12

LINKING TECHNIQUES	13
Join stitch to stitch	13
Join side edge to side edge	13
Join stitch to side edge I	14
Join stitch to side edge II	14
Hold a fabric between stitches	14
Hold a fabric between stitches on ribbed fabric ...	15
Hemming	16
Work chain stitch on a garment	16
Shirr with elastic thread	17
In case of coarse gauge fabric	17
WHAT TO DO IF	18
The yarn is entangled	18
Change the Hook Needle	18
CHECK POINTS	19
MAINTENANCE	19

NAMES OF EACH PART

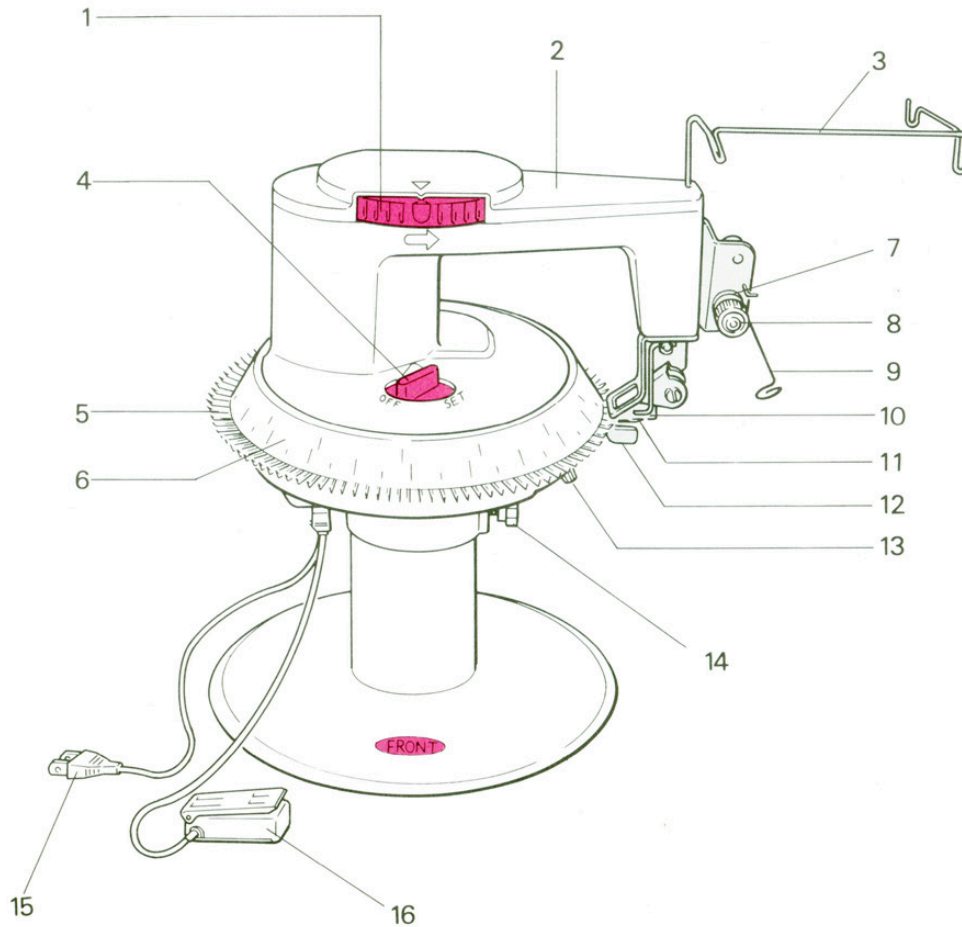

1. Hand wheel
2. Arm
3. Yarn rod
4. Release dial
5. Point needle
6. Crown
7. Tension disc
8. Tension dial
9. Tension spring
10. Yarn guide
11. Hook needle
12. Fabric presser
13. Needle clamp
14. Lock Knob
15. Plug
16. Foot Controller

Accessories

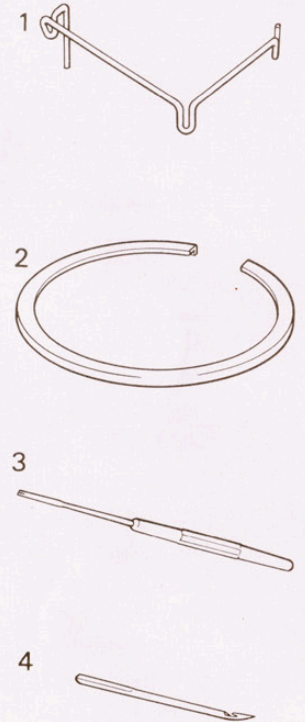

1. Yarn rod
2. Point needle cover
3. Threader
4. Spare hook needle

INSTALLATION

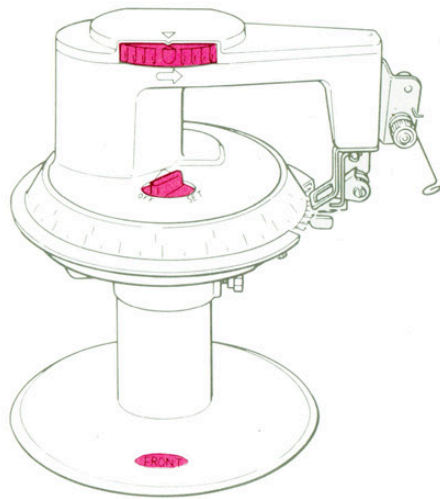

1. Position the Linking Machine on a flat table with the **FRONT** marker facing you.

Note: Ensure that the hook needle is on the right side of the machine. If it is not, loosen the lock knob, turn the head of the machine and fasten the knob.

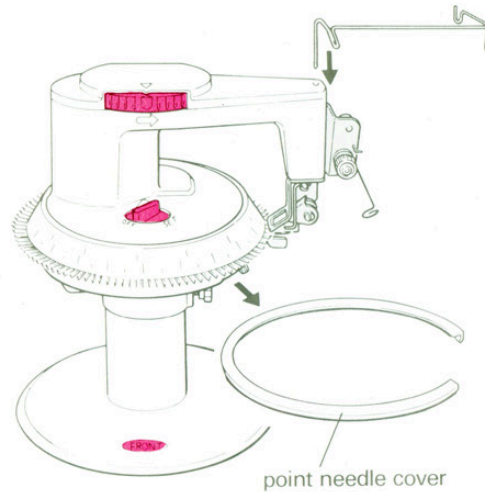

2. Remove the point needle cover.

Cover the point needles with point needle cover while not being used.

3. Install the yarn rod into the socket on the arm as shown above.

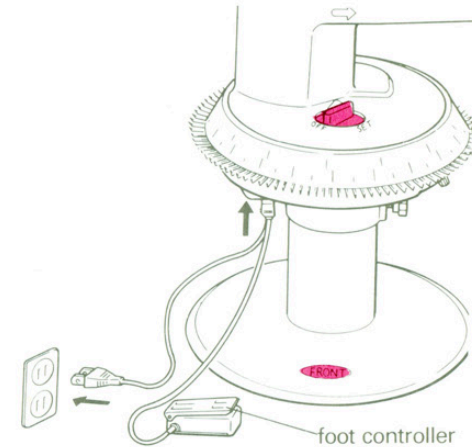

4. Connect the foot controller by plugging it into the machine and plug the other end into a normal outlet.

FUNCTIONS OF EACH PART

RELEASE DIAL

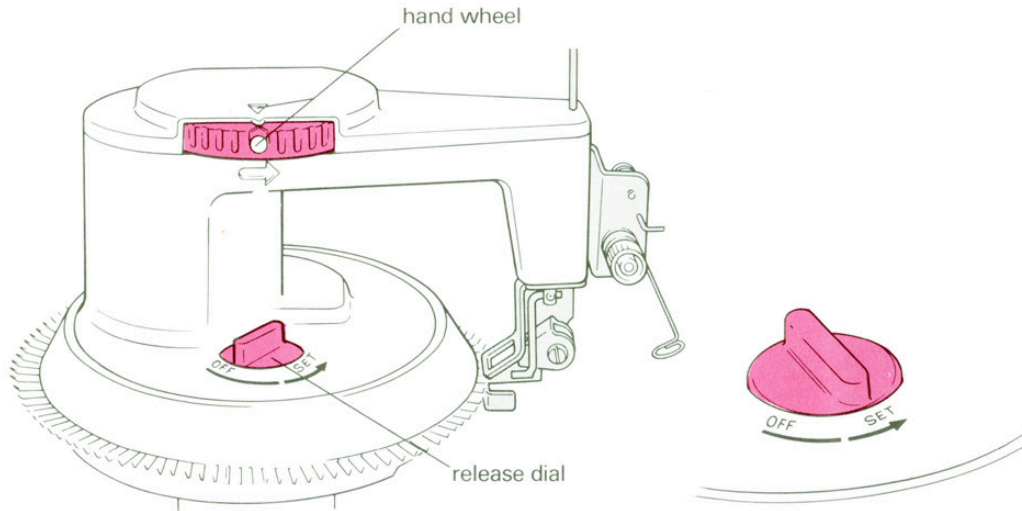

“OFF” (release)

The crown is released from the gear and can be rotated.

Note: When you set release dial to “OFF”, ensure that the pointer of the hand wheel is set to ▼ mark on cover.

Set the dial to “OFF” (release) while hanging fabric on the needles.

“SET”

The crown is set into gear and cannot be rotate by hand.

HAND WHEEL

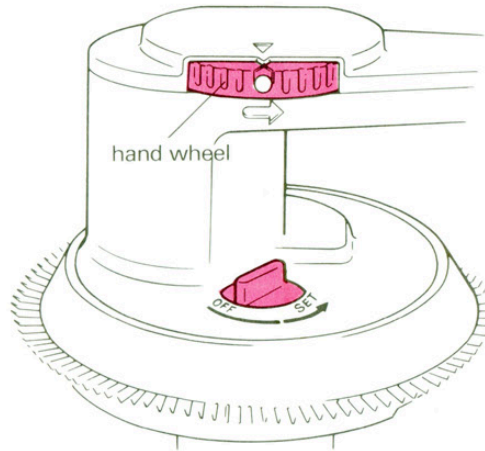

By turning the hand wheel in the direction of the arrow, the hook needle comes out and the crown rotates 1 needle anti-clockwise.

The action of the hook needle is done by rotating the hand wheel.

Before you set the release dial to "OFF", turn hand wheel and match the pointer to ▼ position.

Do not rotate the crown when the pointer is out of position, or the hook needle will knock against the point needles and will be damaged.

HOOK NEEDLE

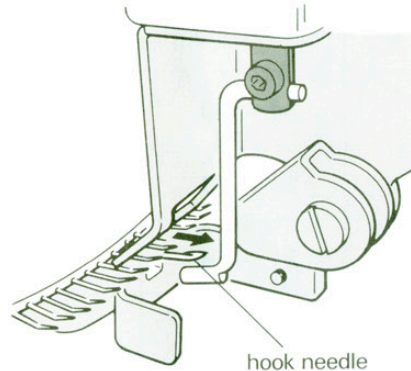

A hook needle is already installed.

Before any operation make sure that the hook needle is inside. To achieve this turn the hand wheel and set its pointer at ▼.

N.B. Extra fine to medium thick and smooth summer yarns are suitable for use on the linking machine.

POINT NEEDLE AND SCALES

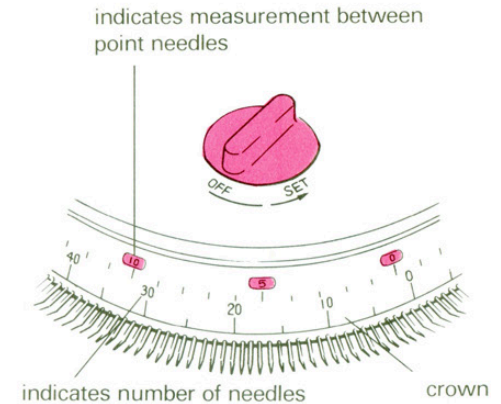

There are two scales on the crown. The scale just above the point needles indicates the number of needles, 220 needles in all, and the upper scale, the metric measure, indicates lengths between root of the point needles.

TENSION DIAL

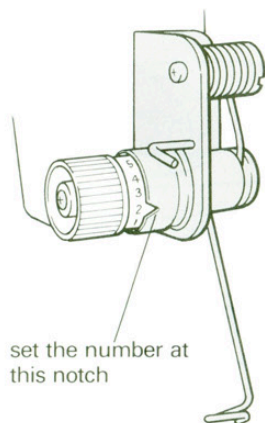

yarn type	stitch gauge (stockinet)	tension dial
thin	34 — 40	5 — 7
medium	29 — 33	3 — 5
thick	24 — 28	1 — 3
*	less than 24	1

Adjust the tension dial by turning it to obtain suitable stitch size. The higher the number, the tighter the stitch. The lower the number the looser the stitch.

Adjust the tension dial following the table above.

* In case the stitch gauge number is less than 24, hang the fabric onto the point needles referring to "In case of coarse gauge fabric". (page 17)

Note: Although the tension dial numbers on the above table are fixed according to the tension gauge, it is necessary to consider the yarn type, stitch type and sections of link.

LOCK KNOB

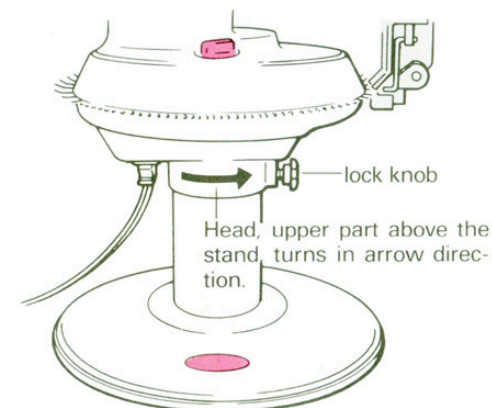

When linking long fabric and it is not able to hang the whole length at the same time, hang the rest by removing the stitched section. In this case, it is not easy to hang onto the rear of the crown as it can't rotate, so loosen the lock knob and turn the head of the machine.

START LINKING

① THREADING THE MACHINE

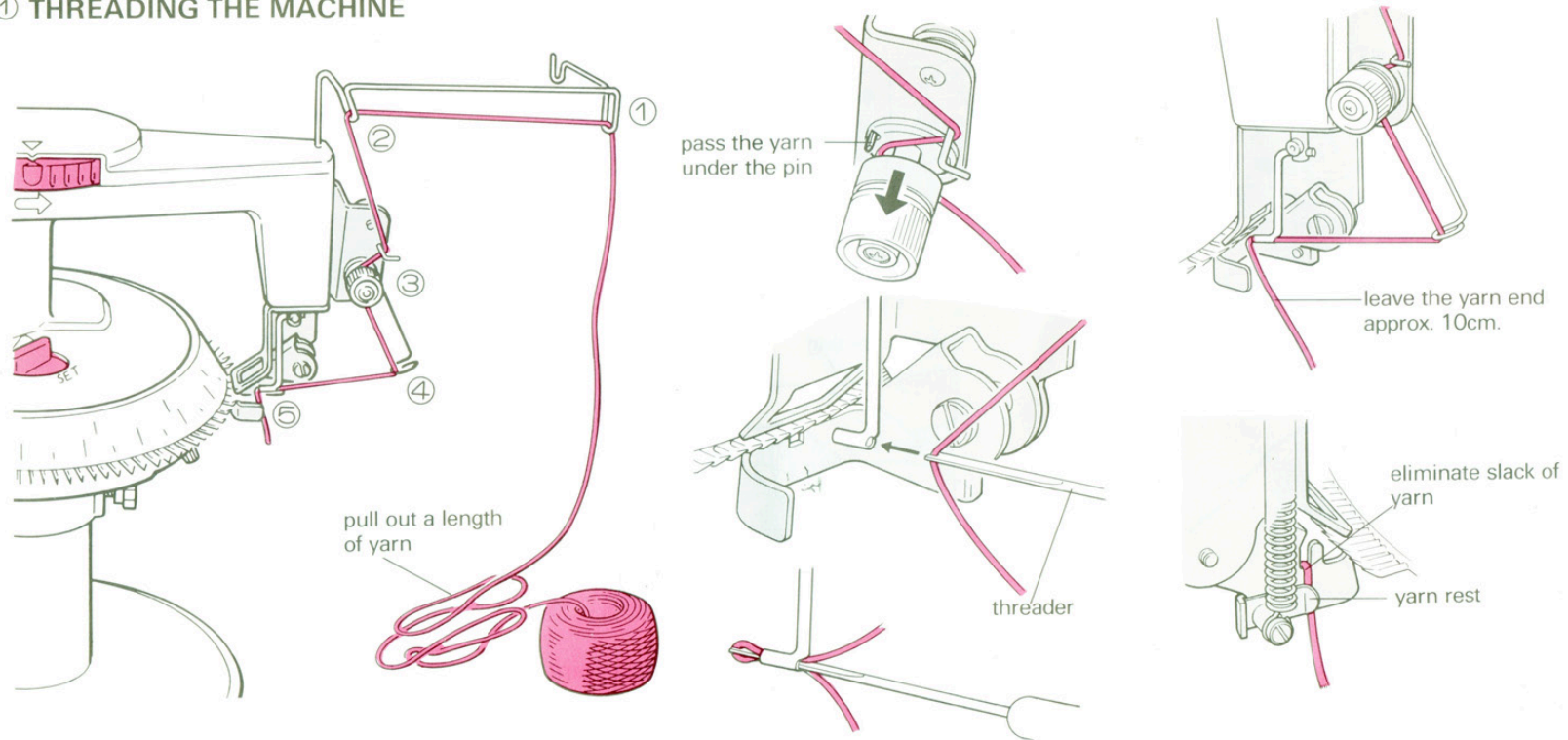

Before threading the machine, move the machine by pressing foot controller with release dial at "SET".

If it doesn't move, ensure plugs are connected correctly.

1. Set hand wheel pointer to ▼ and release dial to "SET".
2. Thread the machine as shown above.

Once the slack has been taken up and you don't intend to continue straight away, place the end of the yarn into the yarn rest.

Adjust tension dial referring to page 6.

② HANG FABRICS

(HANG OPEN STITCHES)

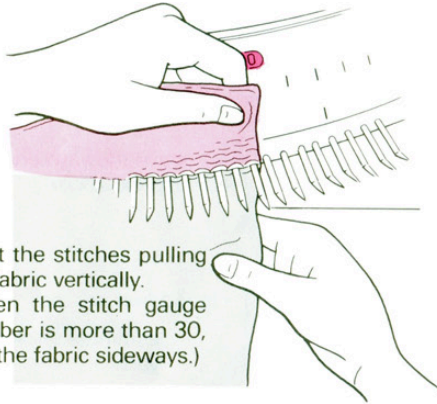

Point the stitches pulling the fabric vertically. (When the stitch gauge number is more than 30, pull the fabric sideways.)

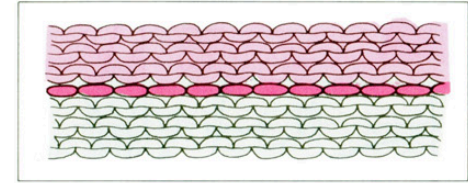
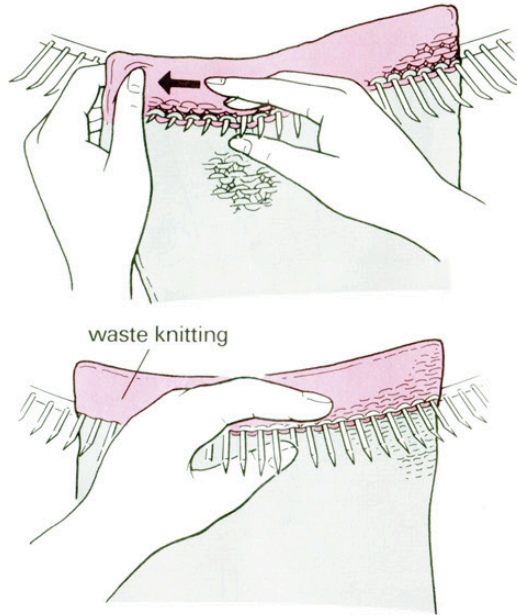

this side

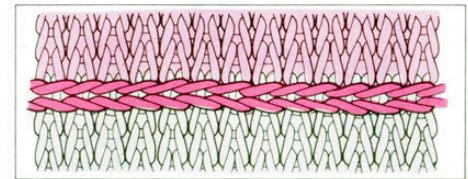

reverse side

Remove the fabric with 3—4cm. of waste knitting.

1. Hook the stitches one by one onto a point needle starting from scale "0" to the left hand direction.

2. Push the fabric towards root of the point needles.

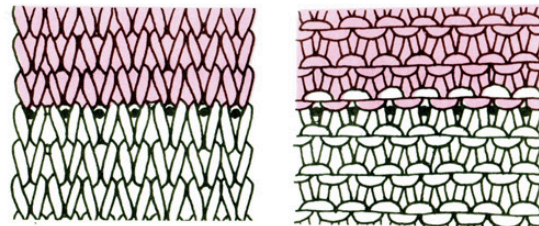

Point the needles as shown above

Note: Chain stitches are formed on the reverse side.

To form chain stitches on the right side of the fabric, place it with wrong side facing you.

(HANG SIDE EDGE)

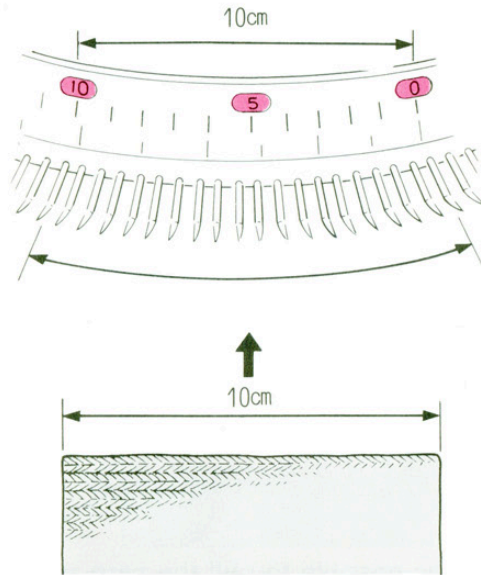

1. Hang the fabric according to its length. If it is 10cm., hang it between 0 and 10 of the upper scale.
2. Push the fabric towards the root of the point needles.

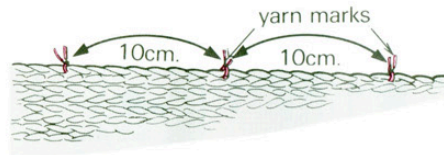
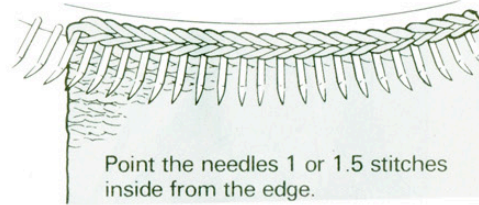

It is advisable to place yarn marks on the edge of the fabric every 10cm.

③ START STITCHING

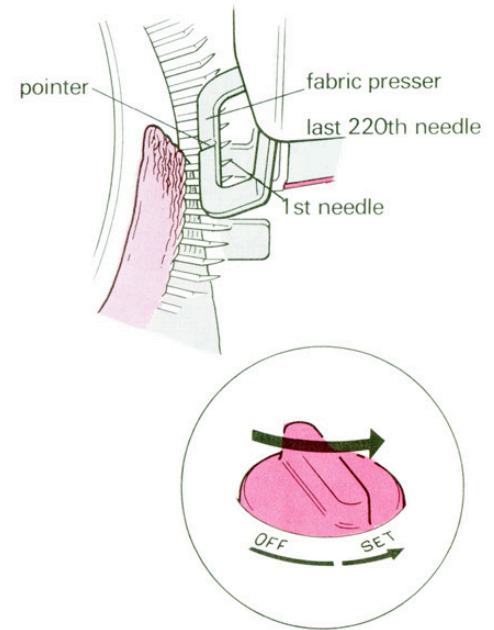

1. Rotate the crown to the right until the last point needle, 220th needle, matches pointer on the fabric presser.
2. Set the release dial to "SET".

④ FINISH STITCHING

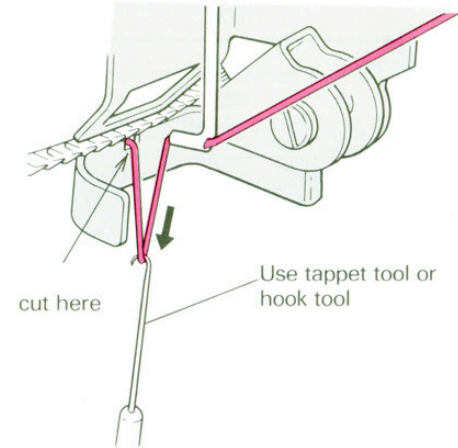
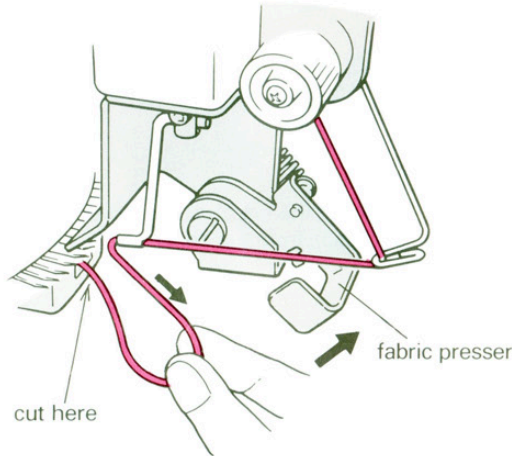
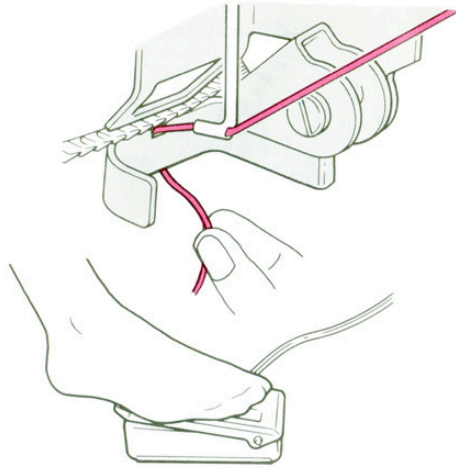

3. Place the yarn onto the cut of the fabric presser, and guide end around.

4. Start stitching by pressing foot controller.

Keep a regular speed, or it will cause uneven stitches.

Note: Do not set the release dial to "OFF" (release) while stitching.

1. Continue to stitch 2 — 3cm. more following the end of the fabric.

2. Set hand wheel pointer at ▼ and release dial at "OFF" position.

3. Turn the fabric presser downwards and away.

4. Pull the yarn between yarn guide and crown, and cut the yarn near the point needle.

Turn back the fabric presser.

It is possible to pull the yarn using a tappet tool or hook tool without turning the fabric presser.

5. Place the yarn into the yarn rest.

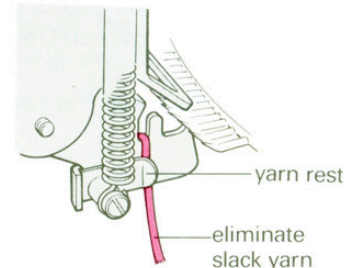

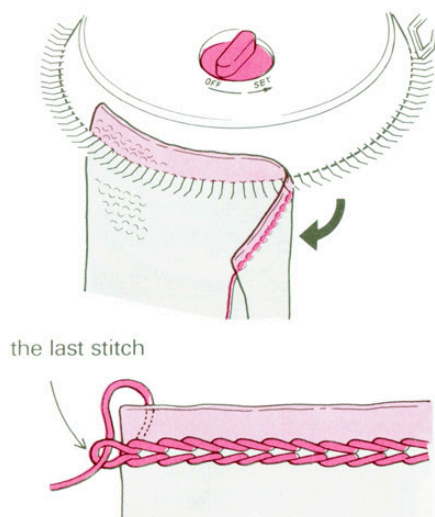

6. Rotate the crown towards the left and remove the fabric from the machine.
7. Undo extra stitches and pass the yarn end into the last stitch.

(CUT THE YARN END USING YARN CUTTER)

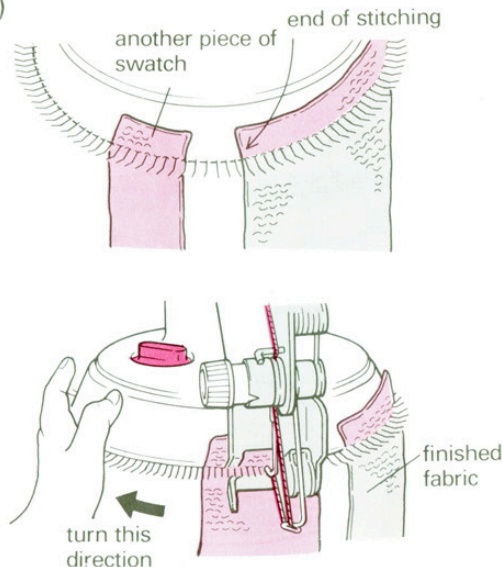

1. Prepare another piece of swatch and hang it onto point needles 2cm. away from the end of the main fabric.
2. Stop stitching at approx. 2cm. in another piece of swatch.
3. Set the hand wheel pointer at ▼, release dial at "OFF" and move the crown to the left hand side with a jerk.
The yarn will be cut.
If there is waste knitting on the left side of fabric, stop stitching on the waste knitting and cut the yarn in the same manner.

(KEEP THE YARN WITHOUT CUTTING)

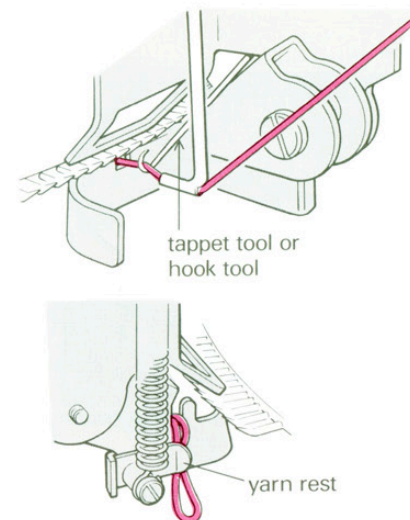

1. Work 5 — 6 extra stitches.
2. Set hand wheel pointer to ▼.
3. Insert tappet tool or hook tool from the back and pull out the yarn towards yarn rest. Hook the yarn into yarn rest without slackening.
4. Move the crown 2 — 3cm. by pressing foot controller.
The yarn will remove from the hook needle.
5. Remove the fabric from the machine, and set hand wheel pointer at ▼ and release dial at "OFF" position.

(WHEN LINKING LONG FABRICS)

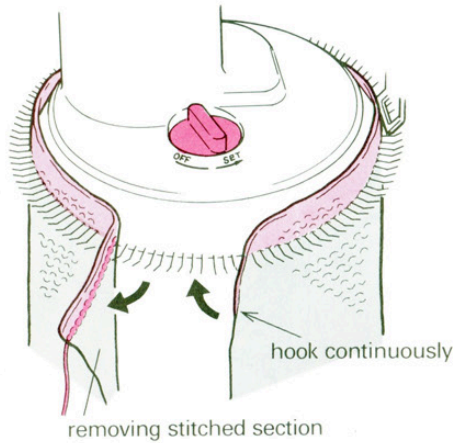

Hang the fabric as long as possible. After stitching this length, remove the stitched section from the point needles and hang remainder. Repeat above manner and you can stitch fabric endlessly.

(CONTINUOUS STITCHING)

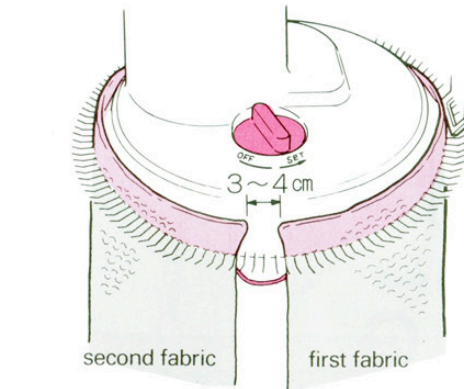
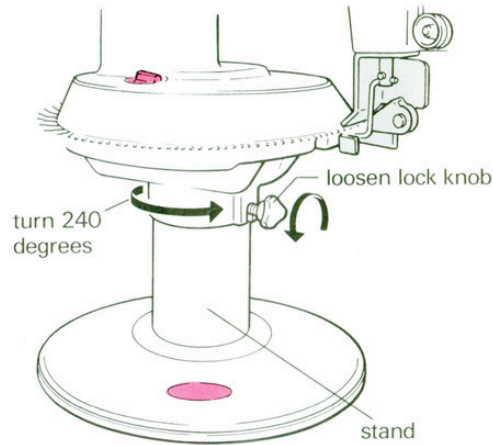

As it is difficult to hang the fabric onto the back of the machine, loosen lock knob and turn the head of the machine anti-clockwise.

To start stitching again, return the head until it stops and fasten the lock knob.

It is easy to stitch continuously to another fabric but keep the second one 3 — 4cm. away from the first one.

Stitch to end of one seam or section. Stitch off edge of fabric. Stitch on to the next section without cutting threads. Cut the chain of thread between each section.

LINKING TECHNIQUES

JOIN STITCH TO STITCH

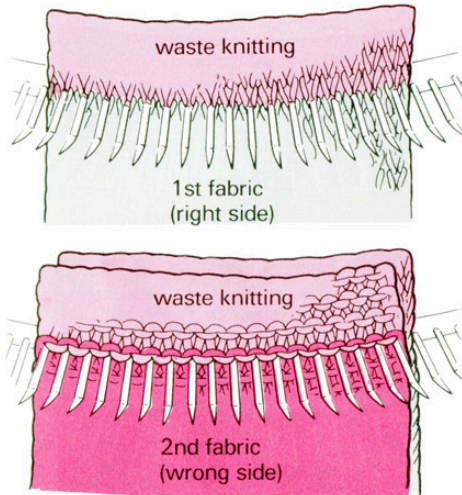

1. With the right side facing you, place the first fabric on the point needles, stitch by stitch.
2. With the wrong side facing you, place the second fabric on the point needles, stitch by stitch.
3. Set the machine for operation and start linking.

JOIN SIDE EDGE TO SIDE EDGE

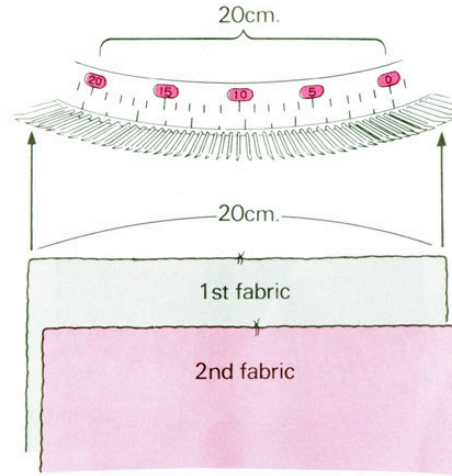

* It is advisable to place yarn marks on the fabric every 10cm.

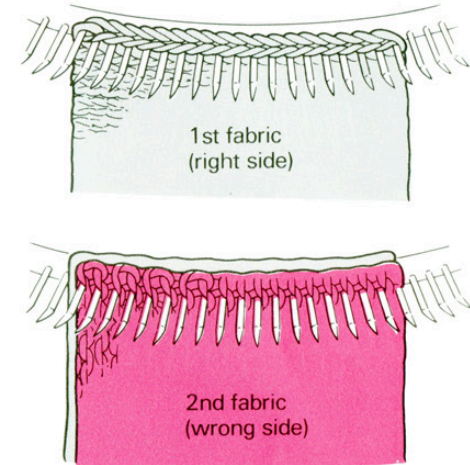

1. With the right side facing you, place the first fabric onto the point needles 1 or 1.5 stitches inside from the edge.
2. With the wrong side facing you, place the second one onto the point needles in the same way.
3. Set the machine for operation and start linking.

JOIN STITCH TO SIDE EDGE I

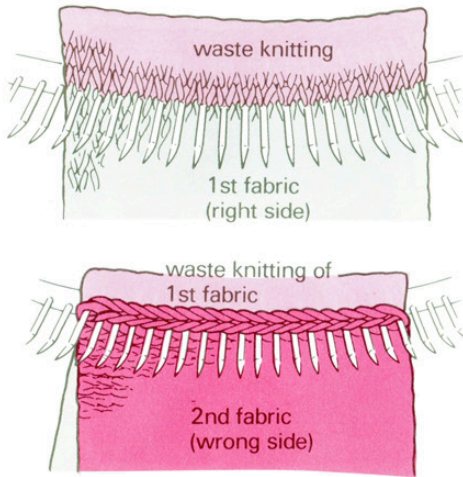

1. With the right side facing you, place the open stitch on the point needles, stitch by stitch.
2. With the wrong side facing you, place the side edge on the point needles evenly.
3. Set the machine for operation and start linking.

JOIN STITCH TO SIDE EDGE II

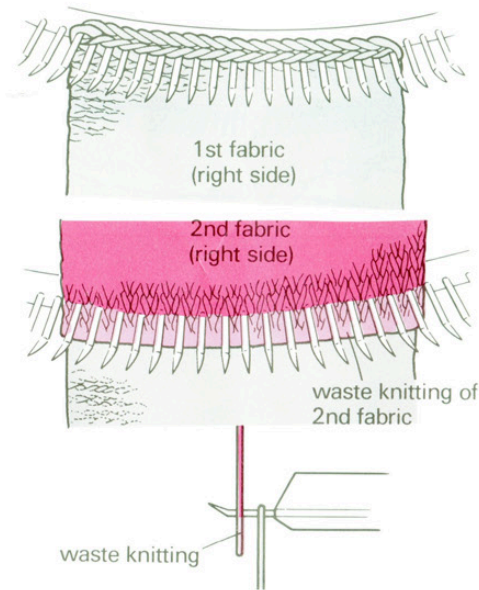

1. Count the number of open stitches for linking.
2. With right side facing you, place the side edge on the same number of point needles as the open stitches.
3. With right side facing you, place the open stitches on the point needles stitch by stitch with the waste knitting downwards.
4. Set the machine for operation and start linking.

HOLD A FABRIC BETWEEN STITCHES

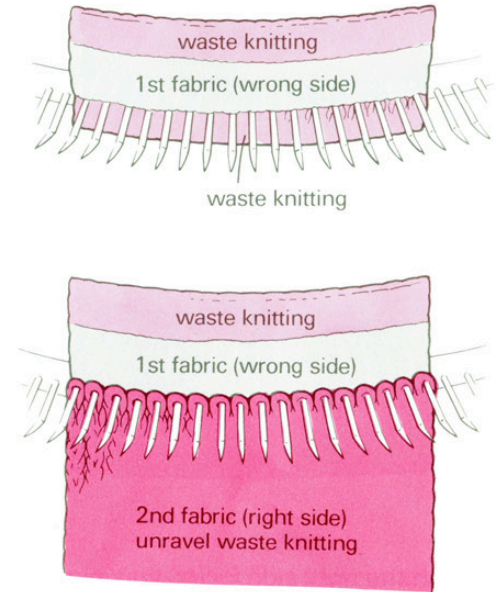

1. With the wrong side facing you, place the first fabric on the point needles with the waste knitting downwards.
2. With the right side facing you, place the fabric to be held onto the point needles.

HOLD A FABRIC BETWEEN STITCHES ON RIBBED FABRIC

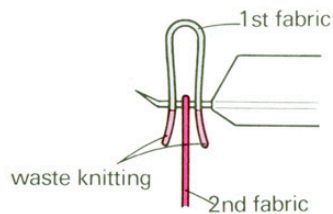
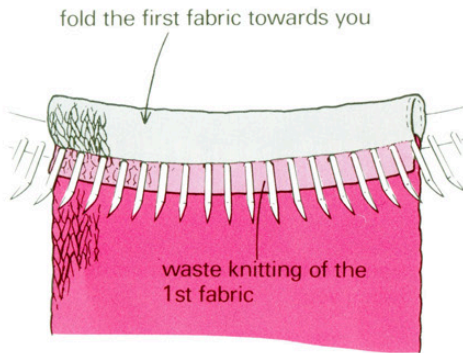

3. Fold the first fabric towards you and place the stitches on the point needles with the waste knitting downwards.
4. Set the machine for operation and start linking.

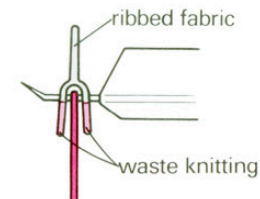
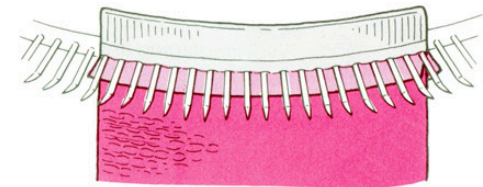
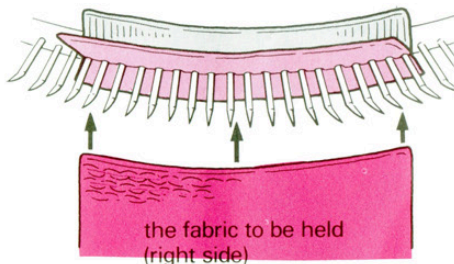
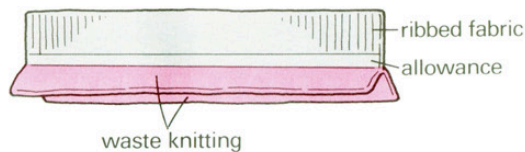

1. Before you knit the waste knitting on the ribbed stitches, knit 2 — 5 rows of allowance with main yarn on knitter and ribber respectively.
2. Work waste knitting on knitter and ribber respectively.
3. With the right side of the ribbed fabric facing you, place the open stitches on the wrong side onto the point needles with waste knitting downwards.
4. Place the fabric to be held on the point needles with the right side facing you.
5. Place the open stitches on the right side of the ribbed fabric onto the point needles.
6. Set the machine for operation and start linking.

HEMMING

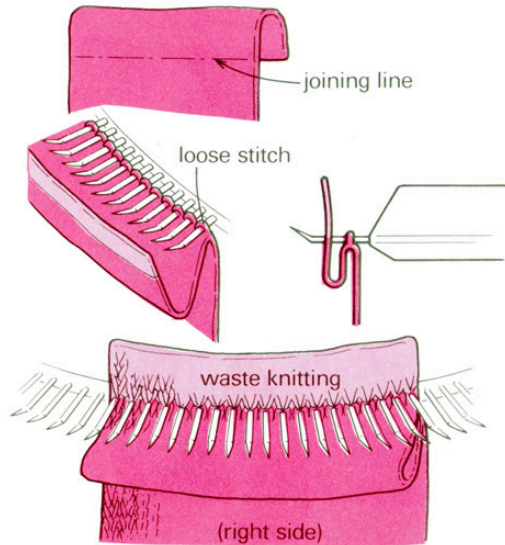

1. Knit joining line with the stitch dial at 2 — 3 numbers looser in advance.
2. Fold the fabric at the joining line with right sides facing each other.
3. Place loose stitches on the point needles with hem as front side.
4. Fold the hem upwards and place the stitches on the point needles.
5. Set the machine for operation and start linking.

WORK CHAIN STITCH ON A GARMENT

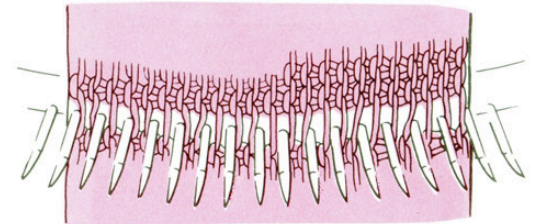
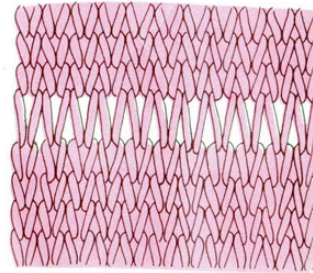
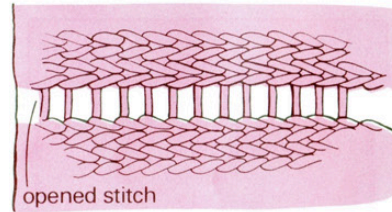

Hang the fabric with wrong side facing you.

1. Open or loosen stitches on the row required in advance to work on chain stitches.
2. With wrong side facing you, place the opened or loosened stitches on the point needles ensuring the stitch direction.
3. Set the machine for operation with tension dial rather loose and start linking.

SHIRR WITH ELASTIC THREAD

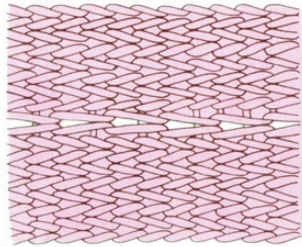

Work slip stitch every other row for shirring.

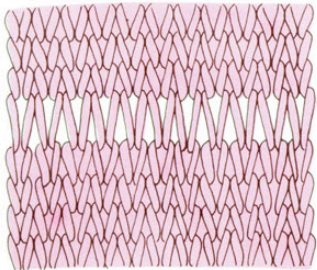

Loosen the row for shirring.

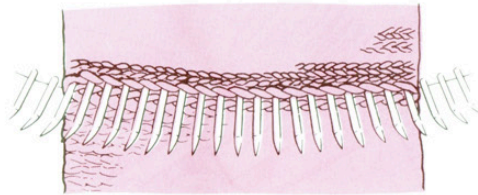

Hook the fabric with right side facing you.

IN CASE OF COARSE GAUGE FABRIC

(In case the stitch gauge number 15 — 18)



point every other needle



point 2 needles per a stitch

(In case the stitch gauge number 18 — 24)



point 3 needles per 2 stitches

1. Work slip stitch every other row or loosen the stitches on the place for shirring in advance.

2. Place the fabric with right side facing you on the point needles.

3. Set the machine for operation with tension dial rather tight and start linking.

According to the tension gauge, place the stitches as shown above.

Use from medium to medium thick yarn as linking yarn.

WHAT TO DO IF...

(THE YARN IS ENTANGLED)

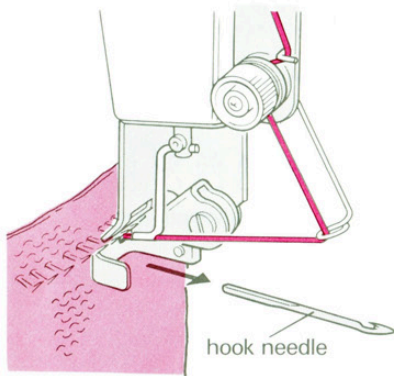

1. Stop operation immediately.
2. Turn the fabric presser and remove the yarn.
3. If it is difficult to remove the yarn from the hook needle, rotate the hand wheel to let the needle out.
4. Loosen the needle clamp and pull out the needle directly.
5. Undo the stitches and start again.

(CHANGE THE HOOK NEEDLE)

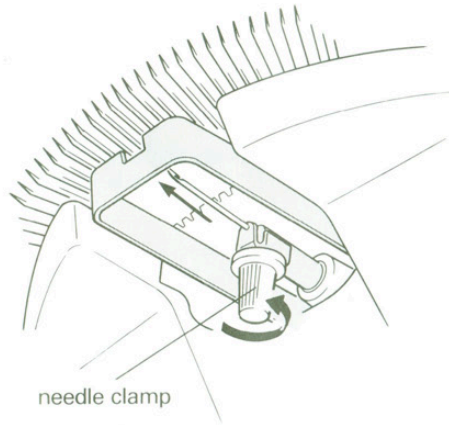

1. Loosen the needle clamp and pull out the old needle directly.

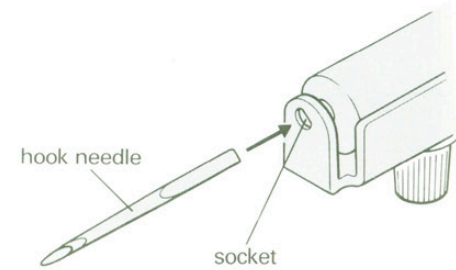

2. Looking at needle socket from below, turn the hand wheel and stop at the most suitable position to insert hook needle.
3. Insert the needle into the socket matching the flat sides with each other.
4. Fasten the needle clamp.

CHECK POINTS

MAINTENANCE

Stitches drop while stitching

Ensure the hook needle is attached correctly.

(See page 18)

If there is a flaw in the hook needle, change it for new one.

(See page 18)

If the point needle is bent, straighten it or change it for new one.

(We suggest to contact selling agent)

Ensure the stitches are pointed correctly onto the point needles.

(See page 8 — 9)

Ensure the yarn is threaded correctly.

(See page 7)

The yarn break while stitching

Ensure the hook needle is attached correctly.

(See page 18)

If there is a flaw in the hook needle, change it for new one.

(See page 18)

Ensure the yarn is threaded correctly.

(See page 7)

Try to loosen the tension dial.

(See page 6)

Do not use delicate yarn or knobbly yarn as linking yarn.

1. Remove the lint from the point needles and wipe with oil damped cloth.
2. Set hand wheel pointer to ▼ and release dial to “SET”.
3. Remove plugs and yarn rod.
4. Fasten the lock knob.
5. Cover the point needles with point needle cover.
6. Repack the machine and keep away from too much moisture, abnormal change of temperature and salt or chemicals.

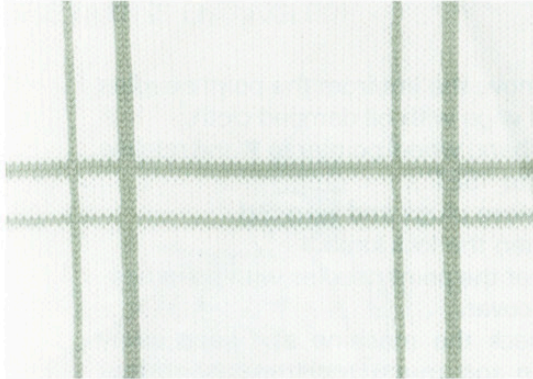

Chain stitch

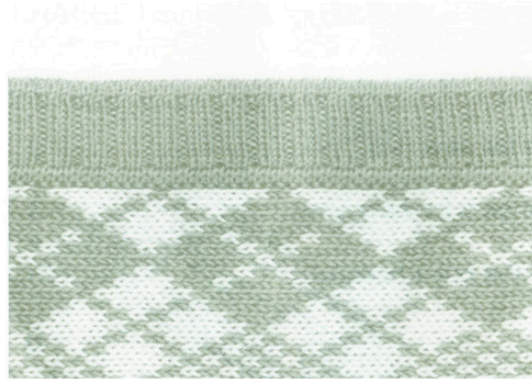

Frontband (hold front edge between ribbed stitches)

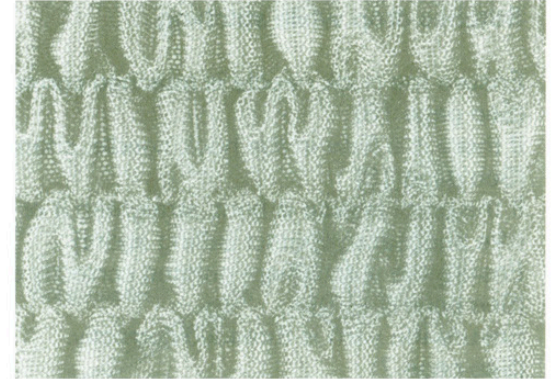

shirring



neckband (stitch to side edge)



neckband (hold neck edge between neckband)

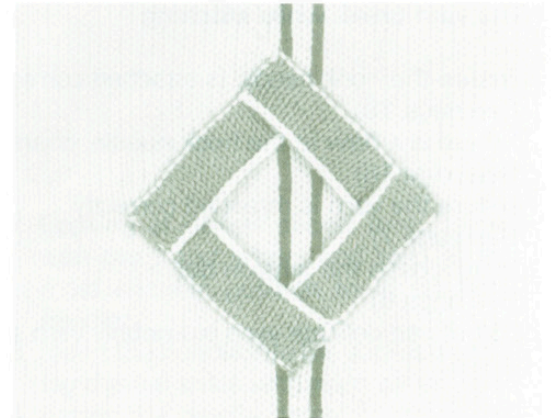

appliqué

